

Heavy & Medium Duty/FREIGHTLINER/Cummins/---//CMMNS/
Cummins/X15/-/-/CM2350/CM2450

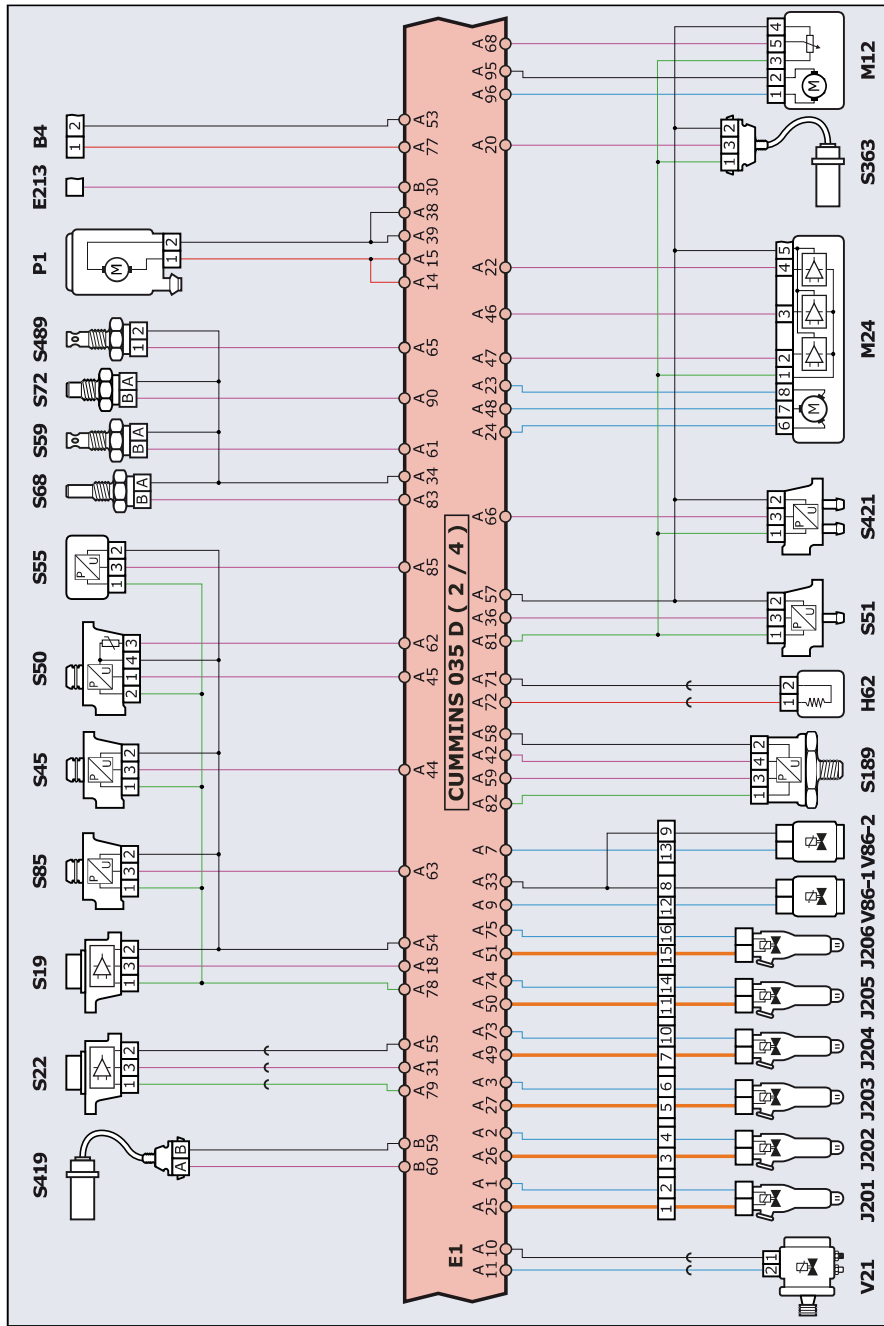

Heavy & Medium Duty/FREIGHTLINER/Cummins/---//CMMNS/
Cummins/X15/-/-/CM2350/CM2450

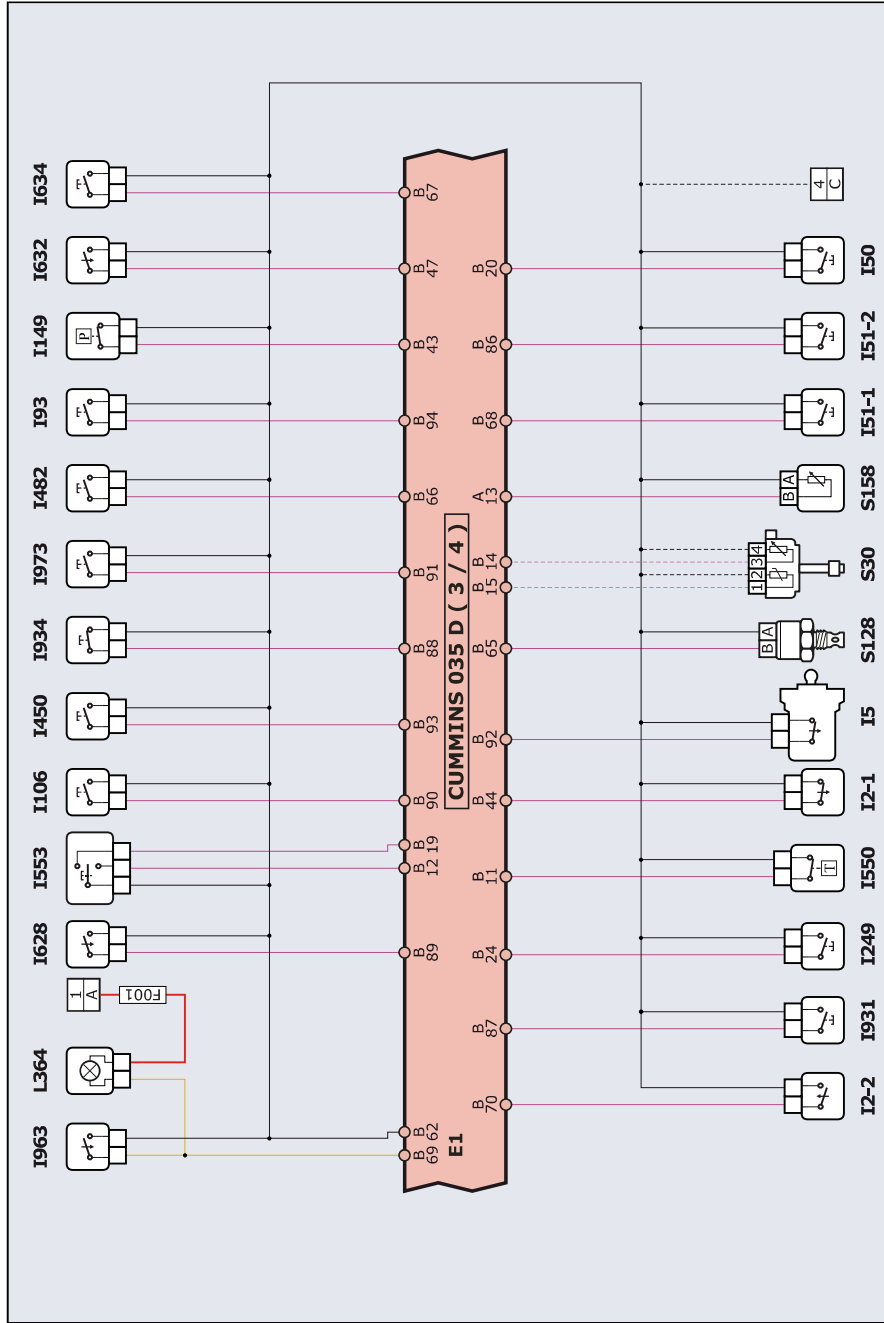

Heavy & Medium Duty/FREIGHTLINER/Cummins/---//CMMNS/
Cummins/X15/-/-/CM2350/CM2450

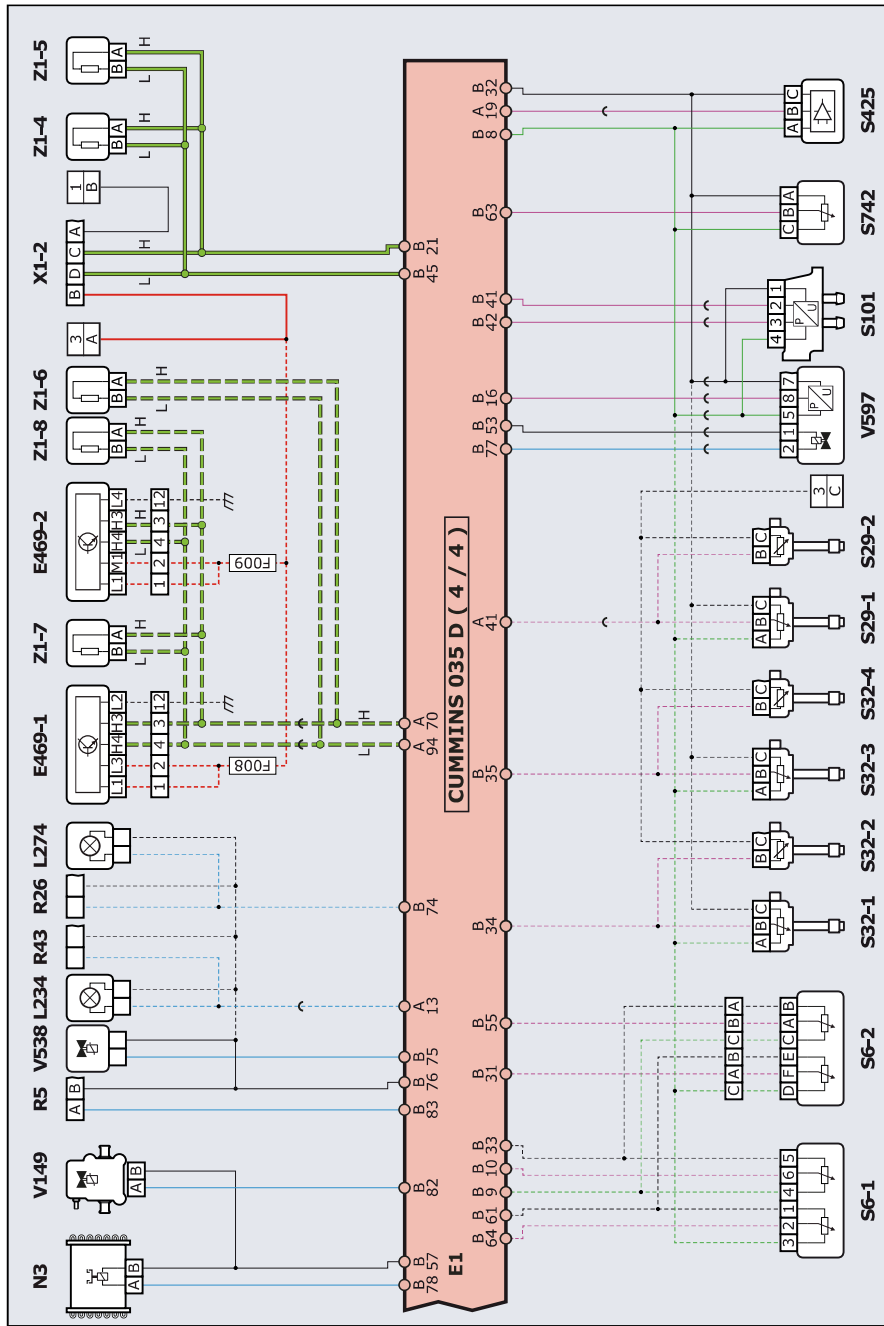

**Heavy & Medium Duty/FREIGHTLINER/Cummins/---//CMMNS/
Cummins/X15/-/-/CM2350/CM2450**
Component list

B1	Starting battery
B4	Backup battery
E1	Engine management control unit
E213	Analog rev indicator
E469-1	Connectivity electronic control unit
E469-2	Connectivity electronic control unit
F001	Fuse amp not defined
F002	30 A fuse
F003	Fuse amp not defined
F004	5 A fuse
F005	15 A fuse
F006	15 A fuse
F007	15 A fuse
F008	5 A fuse
F009	5 A fuse
H62	Engine block oil heater
H8-1	Reducing additive pipeline heater
H8-2	Reducing additive pipeline heater
H8-3	Reducing additive pipeline heater
I1	Ignition Switch
I106	Cruise control switch
I149	A/C pressure switch
I2-1	Brake pedal switch
I2-2	Brake pedal switch
I249	Emergency mode switch
I450	Engine torque limitation switch
I482	Engine speed setting switch
I5	Clutch pedal switch
I50	Parking brake switch
I51-1	Engine brake switch
I51-2	Engine brake switch
I550	Engine cooling fan switch
I553	Set and resume speed switch
I628	Air shut-off solenoid valve test switch
I632	Engine protection switch
I634	External accelerator enabling switch
I93	Power take-off switch
I931	Particulate filter regeneration disabling switch
I934	Override switch
I963	Air cut-off switch
I973	Reductant purge switch
J201	Magnetic common rail injector of cylinder n. 1
J202	Magnetic common rail injector of cylinder n. 2

J203	Magnetic common rail injector of cylinder n. 3
J204	Magnetic common rail injector of cylinder n. 4
J205	Cylinder 5 magnetic common rail injector
J206	Cylinder 6 magnetic common rail injector
L1	Engine malfunction indicator lamp MIL
L225	Exhaust gas overheating warning light
L226	Particulate filter regeneration warning light
L234	Battery indicator light
L27	Engine shutdown warning light
L274	Air shut-off solenoid valve position warning light
L275	Engine fault warning light
L291	Wait-to-start warning light
L364	Lamp
L79	Reducing additive level light
M12	Intake manifold throttle valve motor with potentiometer
M24	Rotary EGR valve control motor with digital position sensor
M35	Variable geometry turbine adjustment motor module
N3	Engine cooling fan clutch solenoid
P1	Fuel pump
P20	Reducing additive pump
PS	The dotted connections may not be present
R245	Reducing additive pipeline heater relay
R26	Idle stop disable relay
R352	Reducing additive pump relay
R393	Exhaust gas after-treatment relay
R43	Stop lights relay
R5	Immobilizer relay
S101	Particulate filter exhaust gas differential pressure sensor
S128	Outside air temperature sensor
S158	Water-in-fuel sensor
S189	High pressure fuel sensor
S19	Hall timing sensor
S22	Hall effect speed sensor
S29-1	Fuel level sensor
S29-2	Fuel level sensor
S30	Reducing additive level and temperature sensor
S32-1	Coolant level sensor
S32-2	Coolant level sensor
S32-3	Coolant level sensor
S32-4	Coolant level sensor
S363	Turbine speed sensor
S419	Vehicle speed sensor
S421	Exhaust gas recirculation differential pressure sensor
S425	Engine cooling fan speed sensor
S45	Atmospheric pressure sensor
S489	Exhaust gas recirculation temperature sensor
S50	Boost pressure and temperature sensor

S51	Exhaust gas pressure sensor
S55	Oil pressure sensor
S59	Intake air temperature sensor
S6-1	Accelerator dual potentiometer
S6-2	Accelerator dual potentiometer
S654	Reducing additive level and quality, temperature sensor module
S656	Exhaust gas temperature sensor module
S68	Coolant temperature sensor
S716	Particulate probe
S72	Oil temperature sensor
S737	NOx sensor upstream of the SCR catalyst
S738	NOx sensor downstream of the SCR catalyst
S742	External accelerator potentiometer
S85	Crankcase oil vapor pressure sensor
V149	Additive tank heating solenoid valve
V21	High pressure fuel metering solenoid valve
V538	Cold start ether injection solenoid valve
V597	Reducing additive dosing module
V86-1	Engine brake solenoid valve
V86-2	Engine brake solenoid valve
X1-1	Diagnostic socket
X1-2	Diagnostic socket
Z1-1	Terminating resistor
Z1-2	Terminating resistor
Z1-3	Terminating resistor
Z1-4	Terminating resistor
Z1-5	Terminating resistor

Heavy & Medium Duty/FREIGHTLINER/Cummins/---//CMMNS/
Cummins/X15/-/-/CM2350/CM2450

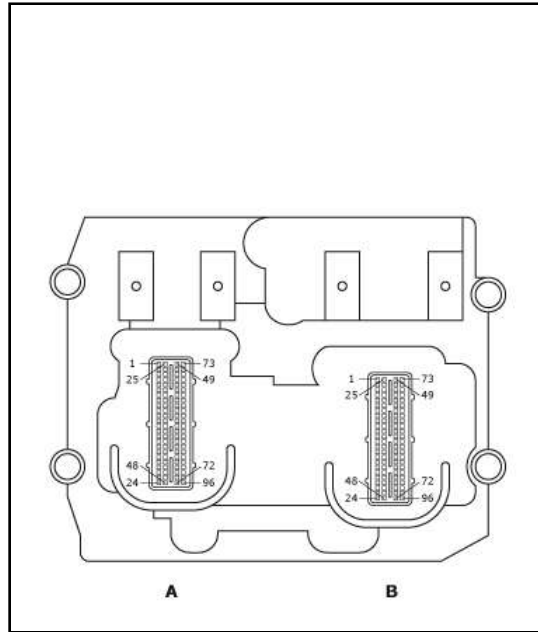

Control unit side connector pinout

A = 96 (J1)

B = 96 (J2)