

RCCS 3 EVO



Rev.

TEXA

ENGLISH.....5

SUMMARY

1 REVISION OF THE MANUAL.....	5
2 INTRODUCTION.....	6
3 LEGEND OF THE SYMBOLS USED.....	7
4 SAFETY RULES.....	9
4.1 Glossary.....	9
4.2 General Rules.....	10
4.3 Operator Safety.....	11
4.4 Equipment Safety.....	13
5 FUNCTIONING OF THE RADIO DEVICES.....	14
6 ENVIRONMENTAL INFORMATION.....	15
7 NORMATIVE INFORMATION.....	16
8 RCCS 3 EVO.....	17
9 PARTS SUPPLIED WITH THE EQUIPMENT.....	18
10 DESCRIPTION.....	19
11 TECHNICAL FEATURES.....	24
11.1 Equipment.....	24
11.2 Motorised Workstation.....	24
11.3 PICOTRONIC laser pointer.....	25
11.4 QUARTON laser pointer.....	26
11.5 Data plates and warning labels.....	27
12 PREPARING FOR USE.....	28
12.1 Positioning of electrical parts	29
13 FASTENING OF THE MONITOR.....	31
13.1 Fastening on a HISENSE monitor: 75A6G, 75A6CG and 75A6FG EUROPE (code 3913217) - 75A6K (code 3915994).....	32
13.2 Fastening on a HISENSE monitor: 75E63KT EUROPE.....	33
13.3 Fastening on a HISENSE monitor: 75A69N and 75E63NT EUROPE.....	34
13.4 Fastening on a HISENSE monitor: 75E7Q and 75E79Q EUROPE.....	35
13.5 Fastening on a HISENSE monitor: 75A7100F (code 3911854).....	37
13.6 Fastening on a HISENSE monitor: 75A7G AUSTRALIA.....	38
13.7 Fastening on a HISENSE monitor: 75A7HAU AUSTRALIA.....	39

13.8	Fastening on a HISENSE monitor: 75A6G and 75A6CG NORTH AMERICA	40
13.9	Fastening on a HISENSE monitor: 75A6N NORTH AMERICA	41
13.10	Fastening on a SONY monitor: KJ-75X80L JAPAN	42
14	POWER SUPPLY	44
15	RCCS 3 EVO UNIT ADJUSTMENTS	45
15.1	Levelling foot adjustment	45
15.2	Calibration plate holder bar adjustment	46
15.3	Calibration procedure	48
15.4	Monitor adjustment	51
15.5	Line laser bracket installation and adjustment	53
15.6	Horizontal adjustment of the workstation	55
16	POWER ON/OFF	56
16.1	Standby	57
17	MINI-PC	58
18	COMMUNICATION	60
18.1	Configuration of the Bluetooth laser distance measurers	61
19	MONITOR SETTING ADJUSTMENTS FOR RCCS 3 EVO	68
19.1	Connection of Sony monitor KJ-75X80L	68
19.2	HISENSE HDMI-CEC control enabling	69
19.3	HISENSE image quality setting	70
19.4	HISENSE Automatic Power-Off settings	71
19.5	HISENSE Power On Mode settings	72
19.6	Power On Mode settings: 75A6N NORTH AMERICA	73
20	ADAS SYSTEM CALIBRATION	74
21	HANDLING	76
22	FIRMWARE UPDATE	79
23	MAINTENANCE	80
24	LEGAL NOTICES	81

1 REVISION OF THE MANUAL

This document is the technical manual for the product: RCCS 3 EVO

Document Review Number: 06

Date of Issue: 11/07/2025

INFORMATION	<i>This manual is an essential part of the product and accompanies it from its birth up to its discontinuation.</i>
	<i>Read this manual before using the product. See the user instructions whenever the general risk symbol is shown in the product, so to understand the source of the danger and carry out the actions required to eliminate or mitigate the risk.</i>

2 INTRODUCTION

Dear Customer,

We would like to thank you for choosing a TEXA product for your workshop.

We are certain that you will get the greatest satisfaction from it and receive a great deal of help in your work.

Please read through the instructions in this manual carefully and keep it for future reference.

Reading and understanding the following manual will help you to avoid damage or personal injury caused by improper use of the product to which it refers.

TEXA S.p.A reserves the right to make any changes deemed necessary to improve the manual for any technical or marketing requirement; the company may do so at any time without prior notice.

This product is intended for use by technicians specialised in the automotive field only. Reading and understanding the information in this manual cannot replace adequate specialised training in this field.

The sole purpose of the manual is to illustrate the operation of the product sold. It is not intended to offer technical training of any kind and technicians will therefore carry out any interventions under their own responsibility and will be accountable for any damage or personal injury caused by negligence, carelessness, or inexperience, regardless of the fact that a TEXA S.p.A. tool has been used based on the information within this manual.

Any additions to this manual, useful in describing the new versions of the program and new functions associated to it, may be sent to you through our TEXA technical bulletin service.

This manual should be considered an integral part of the product to which it refers. In the case it is resold the original buyer is therefore required to forward the manual to the new owner.





















Reproduction, whole or in part, of this manual in any form whatsoever without written authorization from the producer is strictly forbidden.



The original manual was written in Italian, every other language is a translation of the original manual.

© **copyright and database rights2025** The material contained in this publication is protected by copyright and database rights. All rights are reserved by law and under international conventions.

3 LEGEND OF THE SYMBOLS USED

Some of the symbols indicated below may not be used in the manual.

	Toxic material hazard		Laser beam hazard
	Explosive material hazard		Low temperature danger - freezing
	Electric shock hazard		General Risk
	Electromagnetic field hazard		Obligation to read the instructions
	Flammable material hazard		Safety glasses required
	Hot surface hazard		Protective gloves required
	Corrosive substance hazard		Protective clothing required
	Risk of noise level above 80 dB(A)		Respiratory protection required
	Moving Parts Risk		Disconnect mains plug from electrical outlet
	Risk of crushing hands		Do not wet the device
	Floor level obstacle warning		

	This is not a safety symbol. It indicates a hazardous situation which, if not avoided, will result in serious permanent injury or death.
	This is not a safety symbol. It indicates a hazardous situation which, if not avoided, may result in serious permanent injury or death.
	This is not a safety symbol. It indicates a hazardous situation which, if not avoided, may result in minor injury.

<i>NOTICE</i>	This is not a safety symbol. It indicates a hazardous situation which, if not avoided, may result in material damage.
INFORMATION	This is not a safety symbol. It indicates important information.

4 SAFETY RULES

The technology used for the design and manufacturing control of **RCCS 3 EVO** makes it a reliable, simple and safe tool to use.

The personnel in charge of using the equipment are required to follow the general safety rules, use **RCCS 3 EVO** for its intended use only and carry out the maintenance as described in this manual.

All the requirements based on the following must be assessed and applied:

- *Labour inspectorate.*
- *Trade associations.*
- *Vehicle manufacturers.*
- *Anti-pollution regulations.*

4.1 Glossary

Operator: qualified person responsible for using the diagnostic tool.

Equipment: RCCS 3 EVO

INFORMATION

The definition of "operator" cannot be applied to minors or to people with reduced physical, sensory or mental capabilities or without any experience or knowledge required.

4.2 General Rules



The operator must have carefully read and fully understood all the information and instructions in the technical documents provided with the tool. If the operator is not able to read this manual, the operating instructions and safety indications must be read and discussed in the operator's native language.

- *The operator that works on vehicles must have basic qualifications and knowledge of mechanics, automotive engineering, vehicle repairing and of the potential dangers that may arise during self-diagnosis operations.*
- *The operator must be completely clear-headed and sober and not take drugs nor drink alcohol before or when using the equipment.*
- *The operator must follow all the instructions provided in the technical documents.*
- *The operator is required to wear adequate personal protective equipment (PPE) at all times when using the equipment.*
- *The operator must monitor the equipment during the operating phases wherever this is possible in compliance with the safety measures indicated below.*
- *The operator must periodically check the electrical connections of the equipment, making sure they are in good condition and immediately replacing any damaged cables.*
- *The operator must periodically check the parts that are subject to wear and replace them if necessary, using only original spare parts or spare parts approved by the manufacturer.*
- *The operator must stop using the equipment immediately should any failure occur, and promptly contact the technical assistance.*
- *Contact your retailer for extraordinary maintenance operations.*
- *Do not remove or damage the labels/tags and the warnings on the equipment; do not in any case make them illegible.*
- *Do not remove or tamper with any safety devices the equipment is provided with.*

4.3 Operator Safety

WARNING



The equipment uses laser devices for the calibration of vehicle cameras.

Laser beams may seriously damage the retina if pointed directly into the eyes.

Safety Measures:

- *Never look directly at the laser beam.*
- *Do not point the laser beam at people.*
- *Do not point the laser beam at reflecting surfaces not suitable for use in the workshop.*

WARNING



The equipment has been designed to be steady both when being moved and once it is positioned.

Improper movements, positioning or use of the equipment expose to the risk of injuries.

TEXA shall not be liable for any misuse of the equipment.

Safety Measures:

- *Do not tilt the equipment in any way.*
- *Do not climb on the equipment.*
- *Do not sit nor step on the equipment.*
- *Do not hang loads that may compromise the stability of the equipment, causing it to tip over.*
- *Make sure the equipment is steadily positioned on the ground by means of the specific adjustable feet whenever it does not need to be moved.*
- *Before carrying out any movement, make sure the motorised workstation is fully lowered.*
- *Avoid moving it on uneven surfaces.*
- *Move the equipment only as described in the HANDLING chapter.*

WARNING



The equipment has moving parts that may injure the operator.

Safety Measures:

- *Keep hands away from moving parts.*
- *Do not wear ties, loose clothes, wrist jewellery or watches when working near moving parts.*
- *Keep connection cables, probes and similar devices away from the moving parts of the equipment.*

WARNING



In order to position the equipment properly for the calibration of the ADAS, specific laser emitters must be used.

Direct exposure to the light beam produced by the emitters may irreversibly damage the eyes.

Safety Measures:

- *Do not place your eyes into the laser beam path, not even when reflected or run through optical instruments.*
- *Do not point the laser beam at an object or person.*
- *Use the device that includes the laser emitter for its intended use only.*
- *Apply all the safety provisions established by the specific regulations for the use of laser emitters.*

WARNING



The equipment was designed to be electrically safe and to work with specific supply voltage levels.

Failure to comply with the specification related to the power supply may compromise the equipment's safety and efficiency, exposing the operator to the risk of being injured.

Safety Measures:

- *Do not expose the equipment to water or other liquids.*
- *The equipment's power supply must always be connected following the procedures described in this manual.*
- *Do not use external batteries to power the equipment.*
- *Power the equipment using the supplied power adapter only.*

WARNING



The current used during the operating phases generates electromagnetic fields (EMF) near the equipment.

Even though of low intensity, these fields may interfere with medical prostheses, such as pacemakers.

Safety Measures:

- *Keep away from the equipment after launching the operating phases.*
- *If you have a medical prosthesis (e.g.: pacemaker), check with your doctor as to the appropriateness of using the equipment or being near it.*

4.4 Equipment Safety

NOTICE



The equipment was designed to be used in the environmental conditions indicated in the Technical Features chapter.

Using the equipment in environments with temperatures and humidity that differ from those indicated may impair its efficiency.

Safety Measures:

- *Use the equipment indoors only.*
- *Place the equipment in a dry area.*
- *Do not expose or use the equipment near heat sources.*
- *Do not use corrosive chemicals, solvents or harsh detergents to clean the equipment.*

NOTICE



The equipment was designed to be mechanically sturdy and suitable for use in the workshop.

Careless use and excessive mechanical strain may impair its efficiency.

Safety Measures:

- *Make sure the power supply and UP / DOWN button cables were not pinched / stripped while assembling the equipment.*
- *Periodically check that all the screws are well tightened and none are loose.*
- *Do not drop, shake or bump the equipment.*
- *Do not perform any kind of intervention that may damage the equipment.*
- *Do not sit on the horizontal surface (laminated panel) nor use it as a leaning surface.*
- *Do not open or disassemble the electronic parts installed in the equipment.*
- *Move the equipment only on its own wheels.*
- *Be particularly careful when moving the reflecting plate and related tempered glass.*

5 FUNCTIONING OF THE RADIO DEVICES

Wireless connection with Bluetooth® technology

The wireless connectivity with Bluetooth technology is a technology that supplies a standard and reliable method to exchange information between different devices, using radio waves. Other than TEXA products, even products such as cellular phones, portable devices, computers, printers, cameras, pocket PCs etc. use this type of technology.

The Bluetooth interface searches for compatible electronic devices according to the radio signal they generate and establishes a connection between them. TEXA tools operate a selection suggesting only TEXA compatible devices. This does not exclude the presence of other sources of communication or disturbance.

THE EFFICIENCY AND THE QUALITY OF THE BLUETOOTH COMMUNICATION MAY BE INFLUENCED BY THE PRESENCE OF RADIO DISTURBANCE SOURCES. THE COMMUNICATION PROTOCOL HAS BEEN DEVELOPED TO MANAGE THESE TYPES OF ERRORS; HOWEVER, IN THESE CASES COMMUNICATION MAY BECOME DIFFICULT AND CONNECTION MAY REQUIRE SEVERAL ATTEMPTS.

SHOULD THE WIRELESS CONNECTION ENCOUNTER SERIOUS PROBLEMS THAT MAY COMPROMISE A REGULAR COMMUNICATION, THE SOURCE OF THE ENVIRONMENTAL ELECTROMAGNETIC DISTURBANCE MUST BE IDENTIFIED AND ITS INTENSITY REDUCED.

Position the product in order to guarantee the correct functioning of its radio devices. In particular, do not cover it with any shielding or metallic materials in general.



6 ENVIRONMENTAL INFORMATION





Do not dispose of this product with other undifferentiated solid waste.
For information regarding the disposal of this product please see the pamphlet supplied.

7 NORMATIVE INFORMATION

EU declaration of conformity

	<p>The manufacturer, TEXA S.p.A., declares that the equipment type RCCS 3 EVO is compliant with the following directives:</p> <ul style="list-style-type: none"> • <i>EMC 2014/30/EU</i> • <i>LVD 2014/35/EU</i> • <i>RoHS 2011/65/EU and Delegated Directive 2015/863/EU</i> <p>The complete text of the EU declaration of conformity is available at the following Internet address: https://www.texa.com/download</p>
	<p>The manufacturer, TEXA S.p.A., declares that the equipment type RCCS 3 EVO is compliant with the following directives:</p> <ul style="list-style-type: none"> • <i>EMC Regulation 2016 No. 1091</i> • <i>LVD Regulation 2016 No. 1101</i> • <i>RoHS Regulation 2012 No. 3032</i> <p>The complete text of the UK declaration of conformity is available at the following Internet address: https://www.texa.com/download</p>

Other certifications obtained

	<p>The manufacturer, TEXA S.p.A., declares that the equipment type RCCS 3 EVO is compliant with the following standard:</p> <ul style="list-style-type: none"> • <i>AS/NZS 62368.1:2022</i>
	<p>The manufacturer, TEXA S.p.A., declares that the equipment type RCCS 3 EVO is compliant with the following standard:</p> <ul style="list-style-type: none"> • <i>AS/NZS 62368.1:2022</i>

8 RCCS 3 EVO

RCCS 3 EVO (Radar and Camera Calibration System 3 Evolution) is the complete, professional solution developed by **TEXA** for the world of body repair shops, glass replacement specialists and multi-brand workshops: it is ideal to carry out all the calibration operations of cameras and radars.

RCCS 3 EVO allows operating on electronic driver assistance systems through a mini-PC, which allows you to use a display unit of the AXONE Series to send the high-resolution image of the panel required for the calibration to the monitor mounted on the unit.

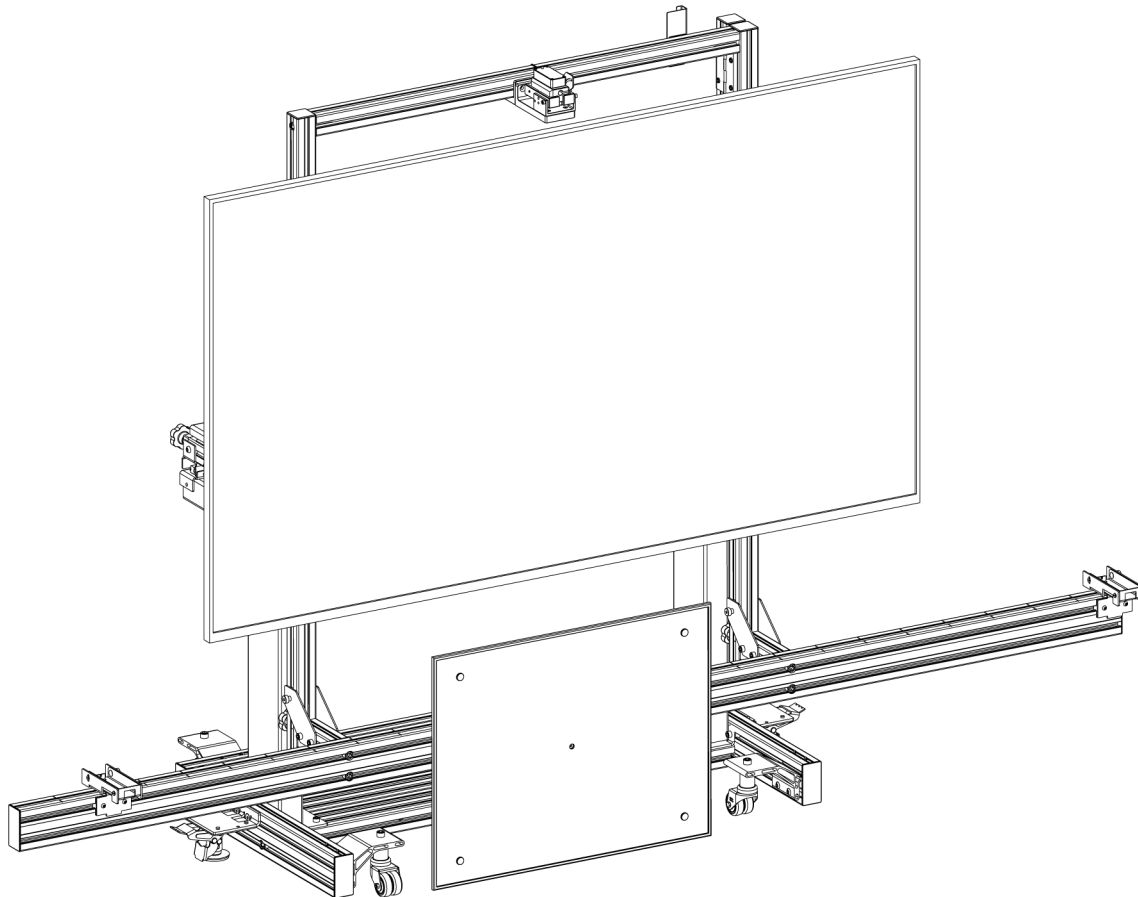

Used in combination with the **IDC5** diagnostic software, the **RCCS 3 EVO** system allows completing all the operations intuitively, saving time.

In fact, the software provides specific diagnostic help sections for each make / model, with the instructions (such as panel height, distance from the vehicle, alignment, etc.) for the correct positioning of the calibration unit, guiding you step by step throughout the procedures.

The laser distance measurers supplied with the calibration unit are equipped with a Bluetooth module.

This module allows connecting them to the diagnostic software, thus optimising the proper positioning of the unit with respect to the vehicle at issue.

Furthermore, at the end of the calibration, you can print a report to hand over to the customer with the evidence of the operations carried out.

9 PARTS SUPPLIED WITH THE EQUIPMENT

With **RCCS 3 EVO** the following elements are supplied:

- *magnetic digital inclinometer;*
- *laser distance measurers;*
- *line laser;*
- *power adapter for motorised workstation;*
- *power cable for motorised workstation;*
- *LED TV monitor;*
- *HDMI - micro HDMI cable;*
- *RPI-VESA mount;*
- *mini-PC;*
- *USB-C power adapter for mini-PC;*
- *power strip;*
- *monitor cover cloth.*

All the supplied accessories are provided with their original manual.



Please refer to the specific manuals provided for information on the correct use and maintenance of the accessories and, in particular, on the safety rules of the devices equipped with laser emitters.

10 DESCRIPTION

RCCS 3 EVO consists of three main parts:

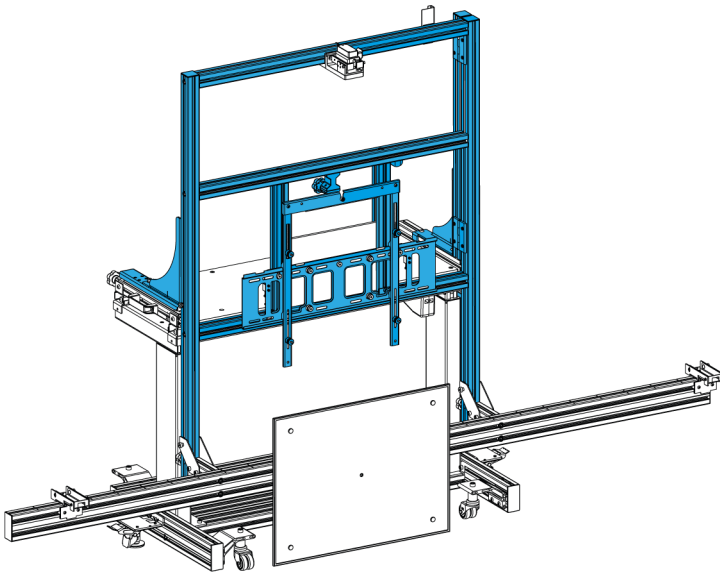

Monitor holder frame

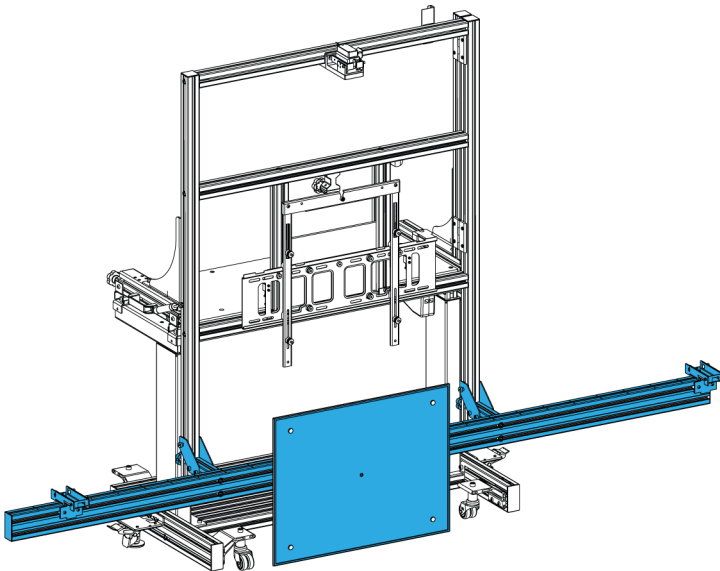

Holder bar for radar calibration plate
and laser distance measurers for
vehicle alignment

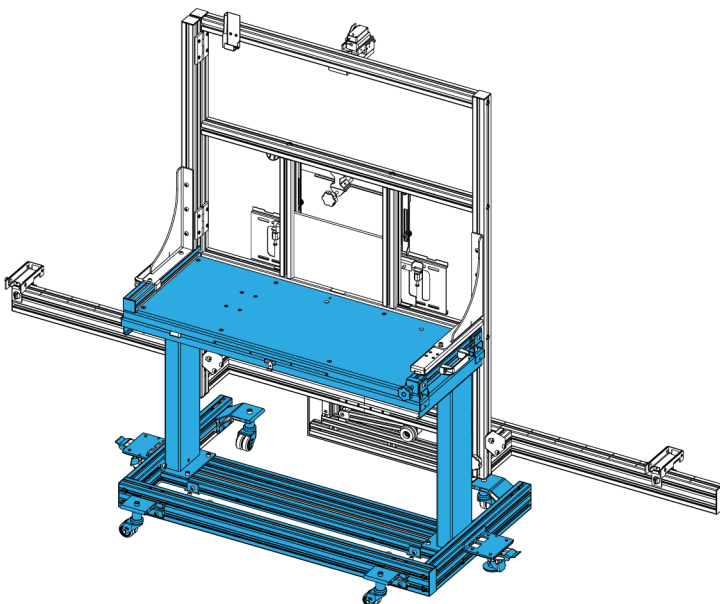

Motorised workstation

INFORMATION

The illustrations in the manual may refer to a previous version of the product.

However, the components that appear different from the ones illustrated, have the same function.

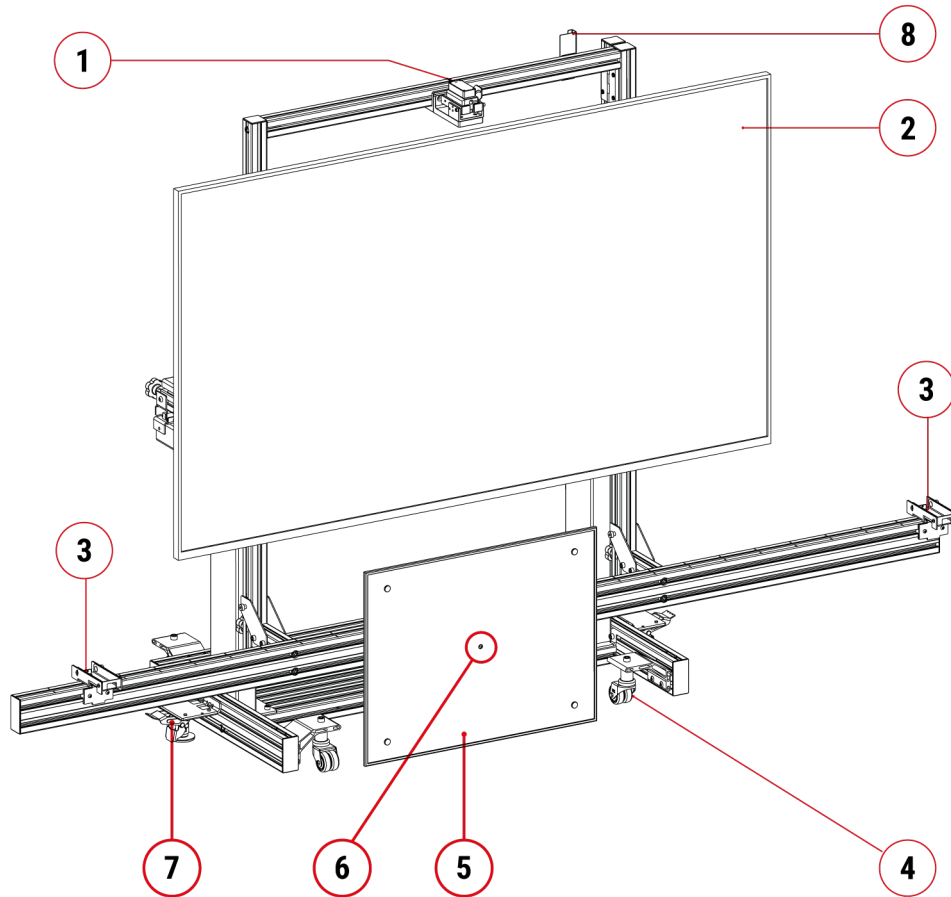

1. Line laser bracket
2. Monitor
3. Bracket for laser distance measurer
4. Castor wheel
5. Radar calibration plate
6. Laser pointer
7. Levelling foot
8. Bracket for laser distance measurer

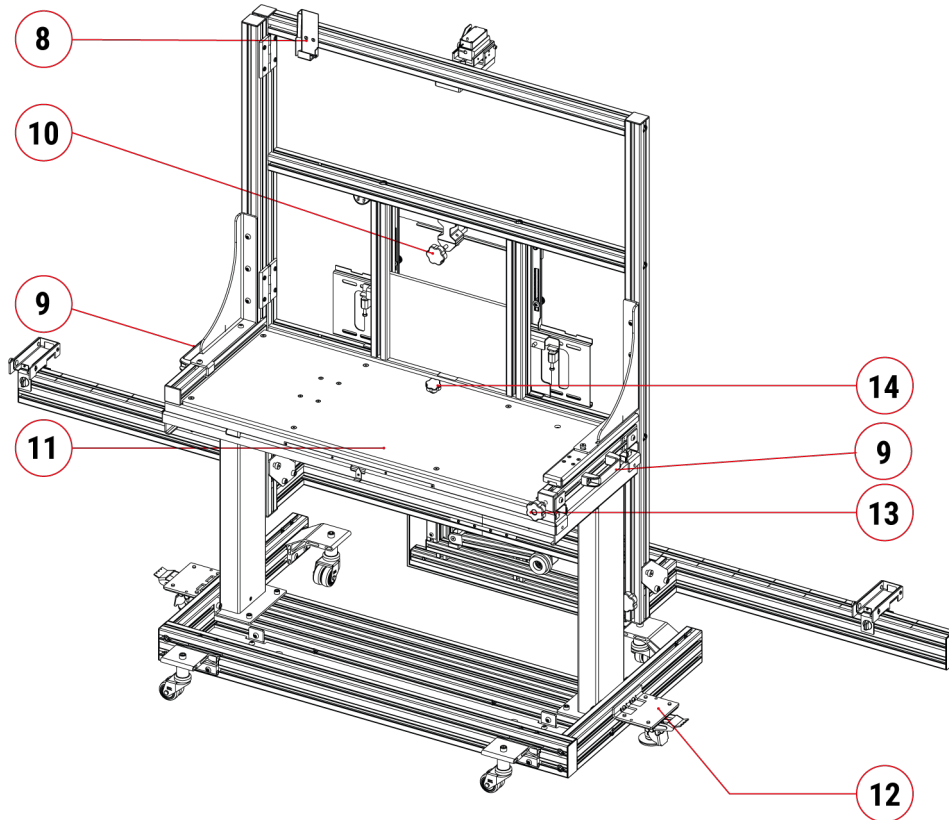

- 8. Bracket for laser distance measurer
- 9. Handle
- 10. Monitor tilt adjustment knob
- 11. Laminate panel
- 12. Levelling foot with brake
- 13. Workstation and lower bar adjustment knob
- 14. Knob to lock/unlock the workstation's horizontal movement

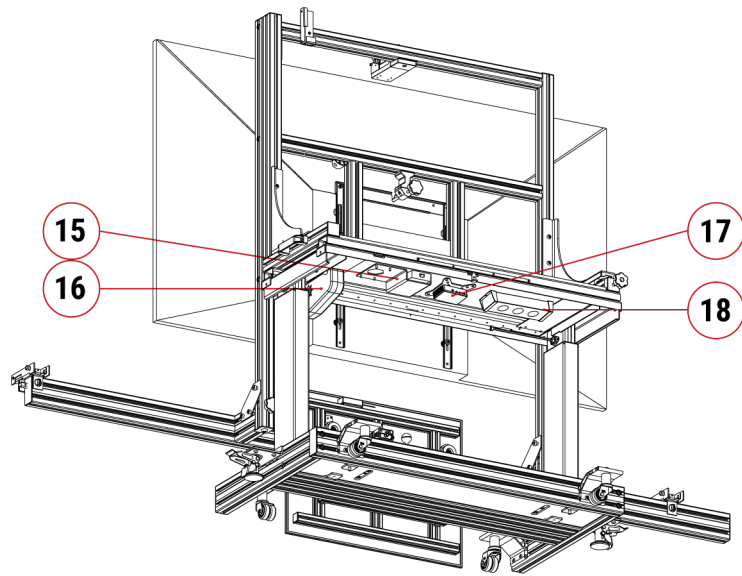

- 15. Power adapter of the motorised workstation
- 16. Workstation motor
- 17. Mini-PC
- 18. Power strip

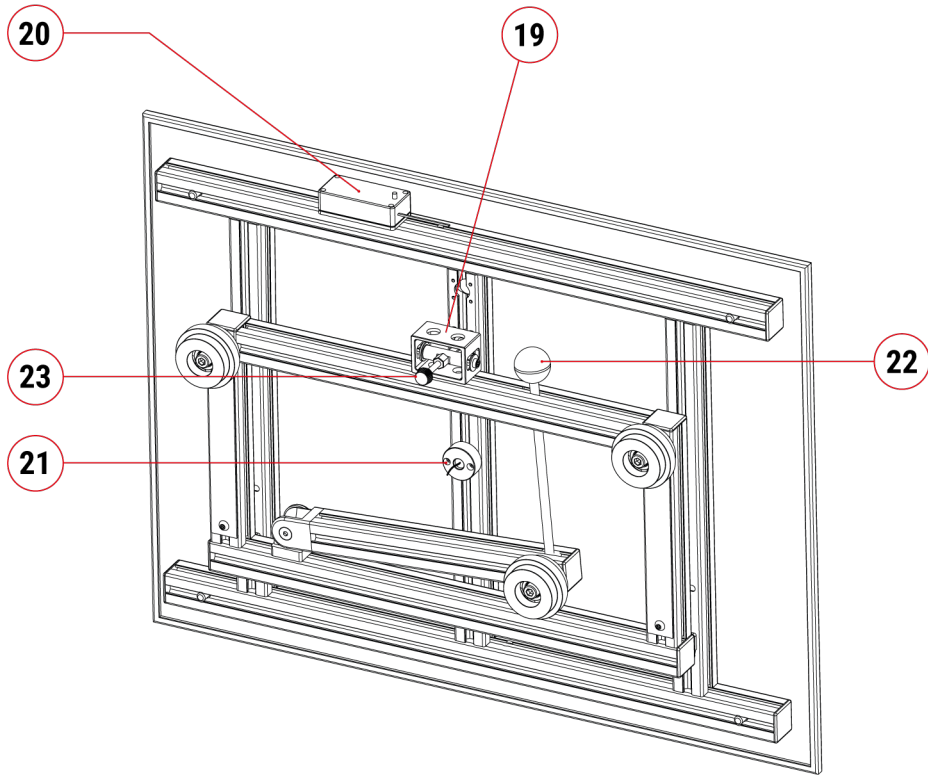

- 19. Calibration plate tilt selector
- 20. Laser pointer battery holder
- 21. Laser pointer
- 22. Calibration plate assembly/disassembly mechanism control knob
- 23. Selector for calibration plate fine-tuning

11 TECHNICAL FEATURES

11.1 Equipment

Manufacturer:	TEXA S.p.A.
Product name:	RCCS 3 EVO
External charger:	100-240 Vac 50/60Hz, 4.0A Max
Operating temperature:	5 °C ÷ 30 °C
Storage temperature:	5 °C ÷ 50 °C
Operating humidity:	< 85 %
Storage humidity:	< 50 %
Dimensions:	2600 x 1700 x 905 mm
Weight:	160 kg
Directives:	EMC 2014/30/EU LVD 2014/35/EU RoHS 2011/65/UE and Delegated Directive 2015/863/EU
Regulations:	EMC Regulation 2016 No. 1091 LVD Regulation 2016 No. 1101 RoHS Regulation 2012 No. 3032

11.2 Motorised Workstation

Manufacturer:	Actiforce
Product name:	Aluforce Pro 140 M
Maximum stroke:	46 cm
Maximum frame load:	60 kg
Frame weight:	26 kg
Speed with 0 kg loaded:	21 mm / s
Speed with 60 kg loaded:	17 mm / s
Input power:	100-240 Vac 50/60Hz, 1.2A
Duty Cycle:	10 % (1 min on / 9 min off)
Noise level:	< 50 dB(A)
Operating temperature:	5 °C ÷ 30 °C
Storage temperature:	5 °C ÷ 50 °C
Operating humidity:	< 85 %
Storage humidity:	< 50 %
FOR INDOOR USE ONLY	

11.3 PICOTRONIC laser pointer

Manufacturer:	PICOTRONIC
Product name:	DBI650-1-3-FA(12x40)-F3400
Item code:	70113303
Beam shape:	Dot
Laser class:	2 / EN 60825-1
Divergence:	B - 0.3 mrad
Beam diameter:	5 mm
Dimensions of the laser dot:	<1.25 mm @ 3.4 m
Operating distance:	3.4 m
Optics:	Anti-reflective coated glass lenses
Laser technology:	Single mode diode
Focus:	Fixed (3.4 m)
Potential of housing:	VDD
Battery:	2 x AA LR6
Data plate:	

11.4 QUARTON laser pointer

Manufacturer:	Quarton inc.
Product name:	VLM-520-55 LPT
Item code:	3916375
Operating voltage:	3~6 Vdc
Operating current:	<200 mA
Optical power:	5.8 mW
Laser power output:	0.54 mW (at 10 cm)
Laser class:	1 / EN 60825-1
Beam shape:	Line
Beam width:	3±0.5 mm @ 5M, 6±0.5 mm @ 10M
Beam accuracy:	40" (±1 mm@5M)
Wavelength:	528 nm
Opening angle:	> 90°
Operating temperature:	-20°C ÷ 65°C
Storage temperature:	-20°C ÷ 85°C
Potential of housing:	Insulating
Data plate:	

11.5 Data plates and warning labels

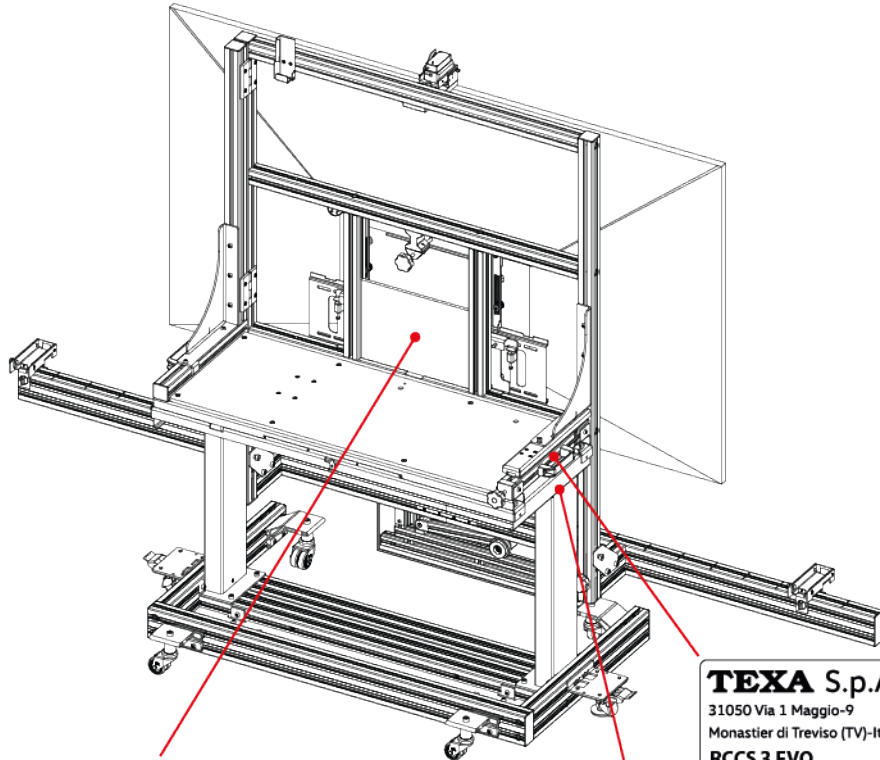



TEXA
 ADAS SETTING SYSTEM

 SCAN HERE
 Product Info

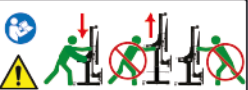

RELEASED
BLOCKED

PRESS THE PEDAL IN ORDER
TO BLOCK THE STRUCTURE





DO NOT MOVE THE STRUCTURE
WHEN THE TABLE IS LIFTED UP.

TEXA S.p.A.
 31050 Via 1 Maggio-9
 Monastier di Treviso (TV)-Italy
RCCS 3 EVO

POWER SUPPLY
 100 - 240Vac 50/60Hz
 4.0A Max

MADE IN ITALY
 3916248

 R-NZ

Actiforce
 Het Steenland 20
 3751 LA Bunschoten-Spakenburg
 The Netherlands

er-T-go Professional 1
 100-240Vac, 1.2A, 50/60Hz
 28Vdc, 90W Max, 3.6A
 Duty Cycle 10%
 AVL-000305-02



12 PREPARING FOR USE

The equipment is delivered disassembled and must be assembled before use.

CAUTION



An inaccurate or incorrect assembly may compromise the unit's functionality and stability and expose the operator to the risk of injuries.

The assembly must be performed by qualified personnel.

The assembly must be performed following the indications in the assembly video.



For further information see the equipment's Assembly video.

To view the Assembly video, scan the QR Code:



12.1 Positioning of electrical parts

When assembling the unit, the electrical and electronic accessories must be positioned under the workstation, among which:

- *power adapter for motorised workstation;*
- *power strip;*
- *Mini-PC;*

DOWN SIDE

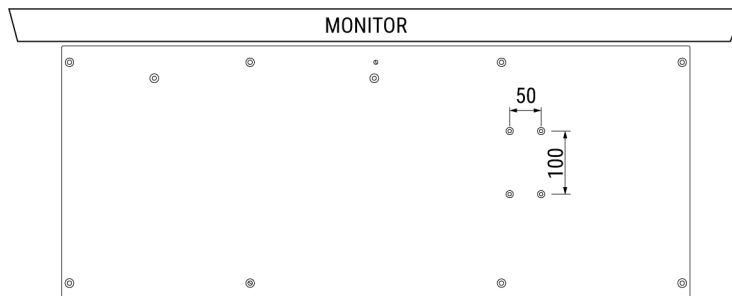

Make sure the abovementioned accessories are properly positioned as indicated in the image.

DOWN SIDE

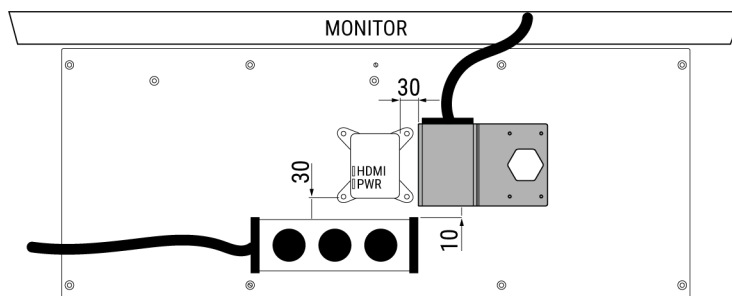

The power strip and mini-PC are fastened to the workstation by the double-sided tape supplied.

The bracket for the motorised workstation's power adapter must be fastened as indicated in the image.

INFORMATION

Gather the cables using the supplied cable ties, so that they do not hinder the handling and diagnostic operations.

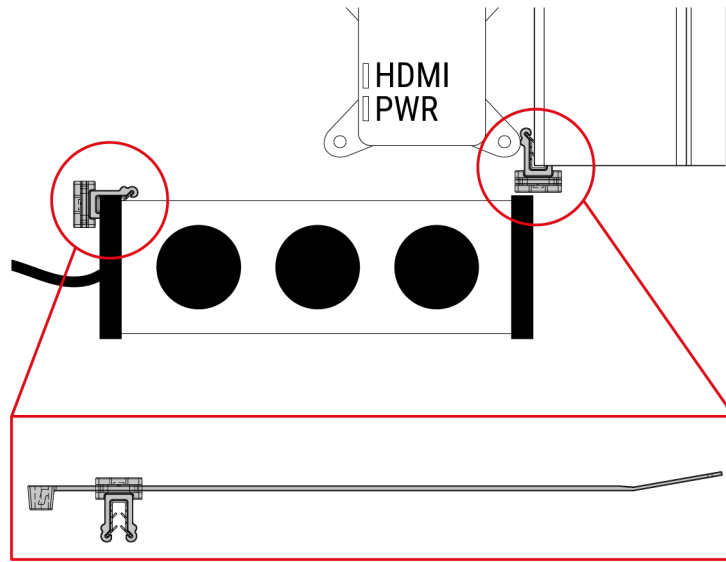

13 FASTENING OF THE MONITOR

The equipment is designed to accommodate the installation of several types of monitors. Before installing the monitor, you must fasten the RPI-VESA mount's brackets to the monitor. The fastening of the brackets is different based on the type of monitor provided.

Pay the utmost attention when choosing the screws that should be used and be sure to position the brackets correctly.

Below are the parts to be used depending on the model chosen.



WARNING

TEXA shall not be liable for an improper installation and a misuse of the equipment.

CAUTION

After securing the monitor, be sure to connect it properly to the mini-PC located under the motorised workstation.

Make sure to carry out the proper settings based on the type of monitor used.

For further information see the MONITOR SETTING ADJUSTMENTS chapter.

13.1 Fastening on a HISENSE monitor: 75A6G, 75A6CG and 75A6FG EUROPE (code 3913217) - 75A6K (code 3915994)

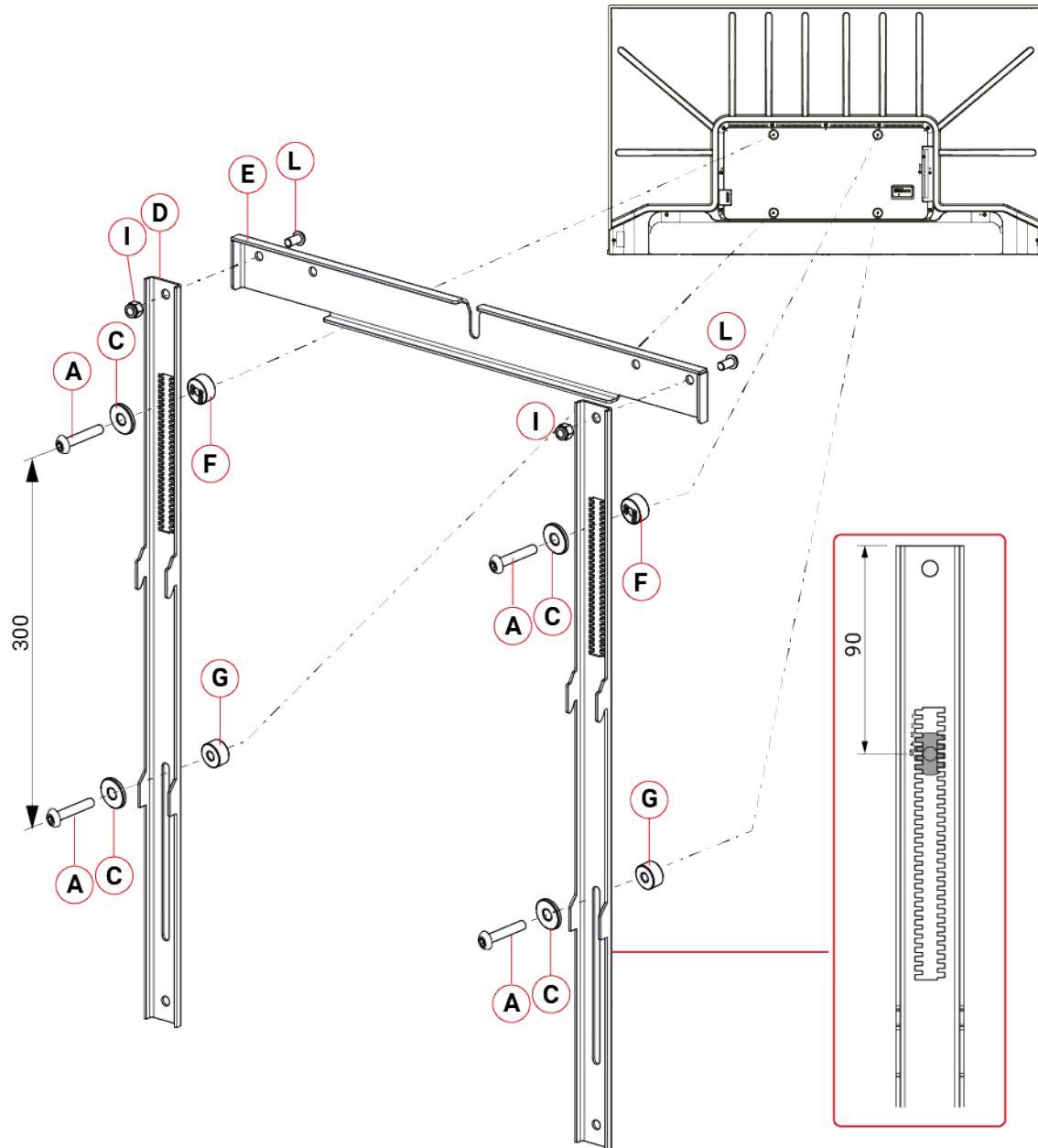

REF.	CODE	DESCRIPTION	Qty.
A	6900396	TBEI M6x25 screw	4
C	6900089	6x18 washer	4
D	3913344	Monitor brackets	2
E	3916134	Monitor tilt bracket	1
F	3913346	Toothed spacer 10 mm	2
G	3913345	Spacer 10 mm	2
I	4150601	M6 self-locking nut	2
L	6900196	TBEI M6x12 screw	2

Fasten the assembled monitor to the RPI-VESA mount.

13.2 Fastening on a HISENSE monitor: 75E63KT EUROPE

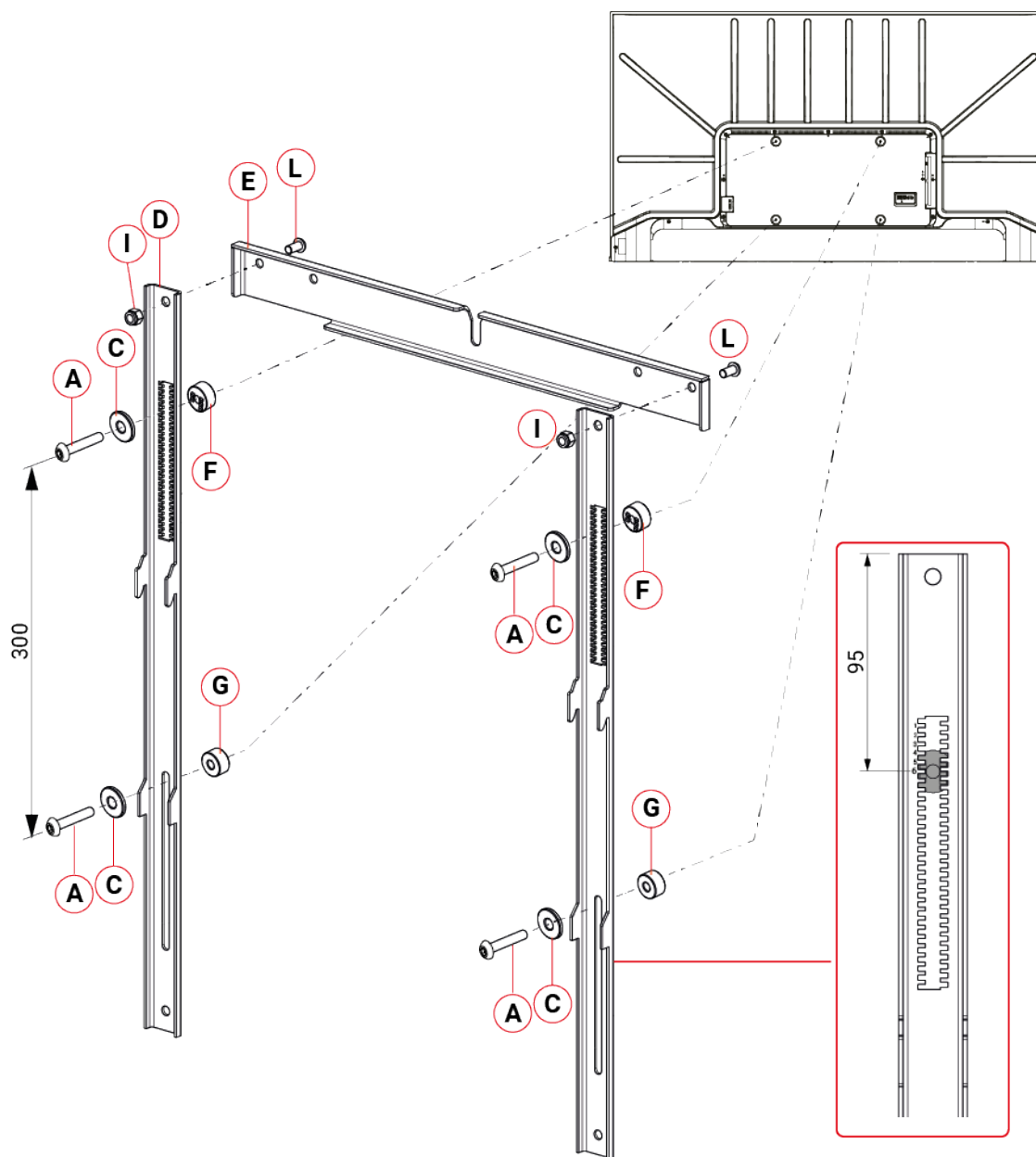

REF.	CODE	DESCRIPTION	Qty.
A	6900396	TBEI M6x25 screw	4
C	6900089	6x18 washer	4
D	3913344	Monitor brackets	2
E	3916134	Monitor tilt bracket	1
F	3913346	Toothed spacer 10 mm	2
G	3913345	Spacer 10 mm	2
I	4150601	M6 self-locking nut	2
L	6900196	TBEI M6x12 screw	2

Fasten the assembled monitor to the RPI-VESA mount.

13.3 Fastening on a HISENSE monitor: 75A69N and 75E63NT EUROPE

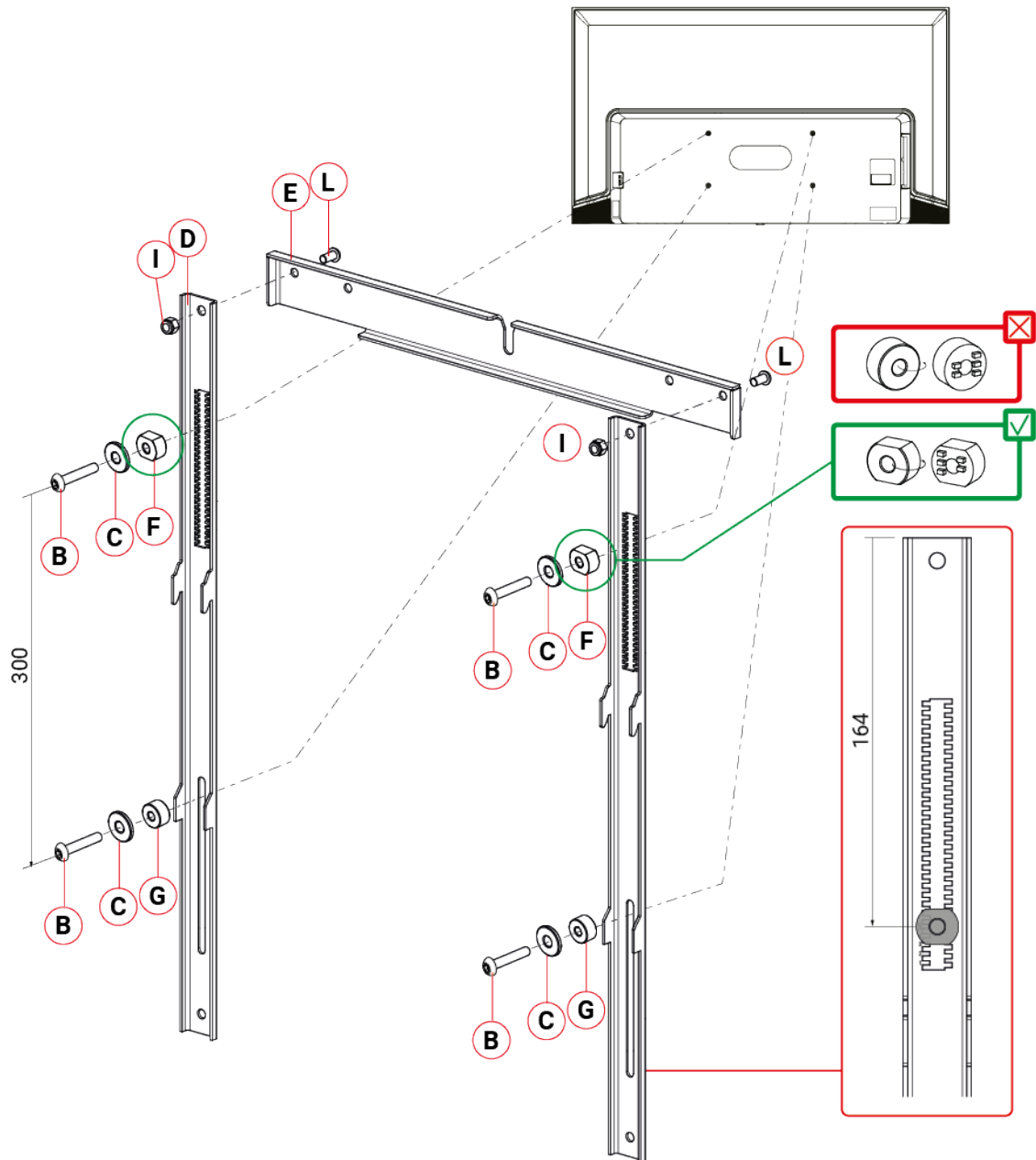

REF.	CODE	DESCRIPTION	Qty.
B	6900396	TBEI M6x25 screw	4
C	6900089	6x18 washer	4
D	3913344	Monitor brackets	2
E	3916134	Monitor tilt bracket	1
F	3918487	Toothed spacer 10 mm	2
G	3913345	Spacer 10 mm	2
I	4150601	M6 self-locking nut	2
L	6900196	TBEI M6x12 screw	2

Fasten the assembled monitor to the RPI-VESA mount.

13.4 Fastening on a HISENSE monitor: 75E7Q and 75E79Q EUROPE

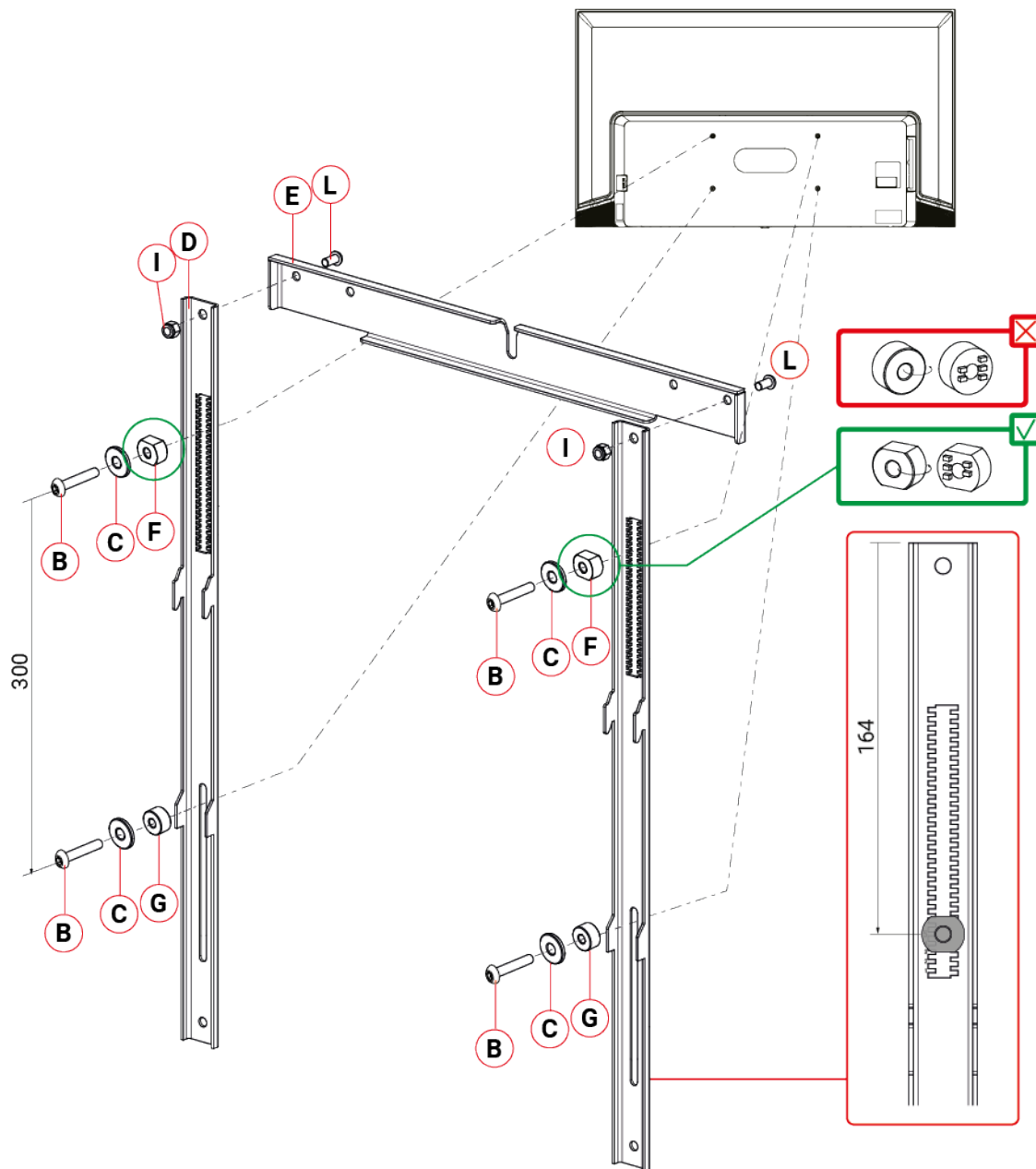

REF.	CODE	DESCRIPTION	Qty.
B	6900396	TBEI M6x25 screw	4
C	6900089	6x18 washer	4
D	3913344	Monitor brackets	2
E	3916134	Monitor tilt bracket	1
F	3918487	Toothed spacer 10 mm	2
G	3913345	Spacer 10 mm	2
I	4150601	M6 self-locking nut	2
L	6900196	TBEI M6x12 screw	2

Fasten the assembled monitor to the RPI-VESA mount.

CAUTION

Upon the first When first switched on, the HISENSE 75E7Q and 75E79Q monitors must be configured.

Connect the monitors to the Mini-PC before configuring them.

To configure the monitors, proceed as follows:

1. **Select Settings.**
2. **Select System.**
3. **Select Advanced Settings.**
4. **Select Default Startup Page.**
5. **Set Last Accessed Source.**

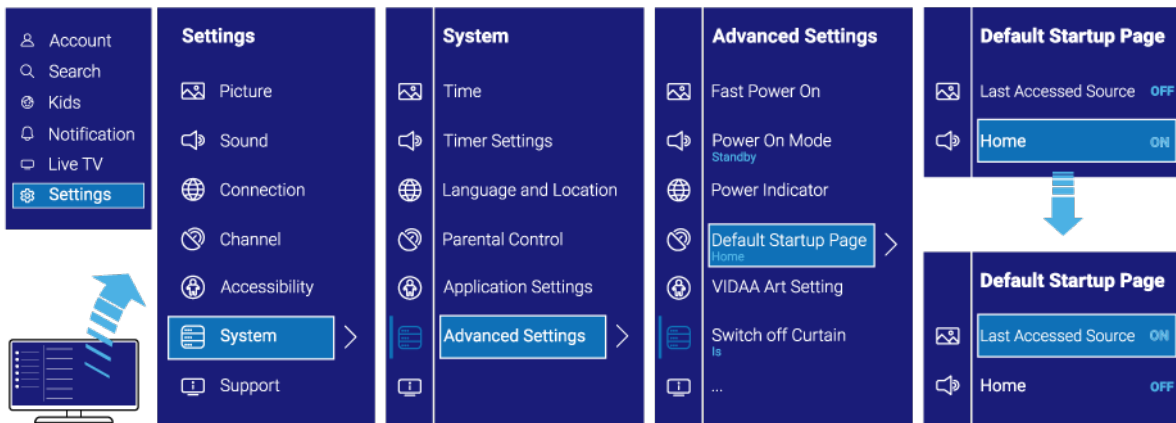

To set the image mode, proceed as follows:

1. **Select Settings.**
2. **Select Picture.**
3. **Select Picture Mode.**
4. **Set Dynamic.**
5. **Return to the MAIN menu pressing the BACK button.**
6. **Select HDMI 1.**

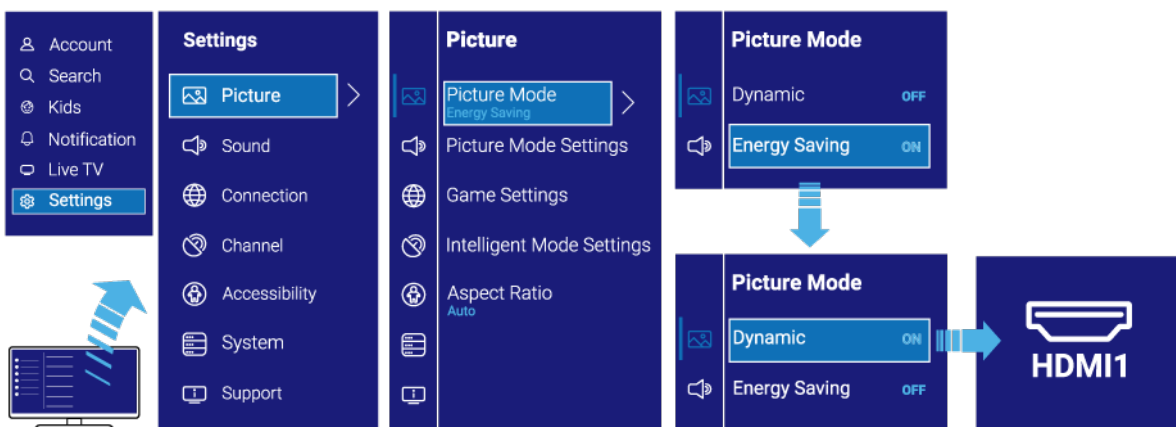

13.5 Fastening on a HISENSE monitor: 75A7100F (code 3911854)

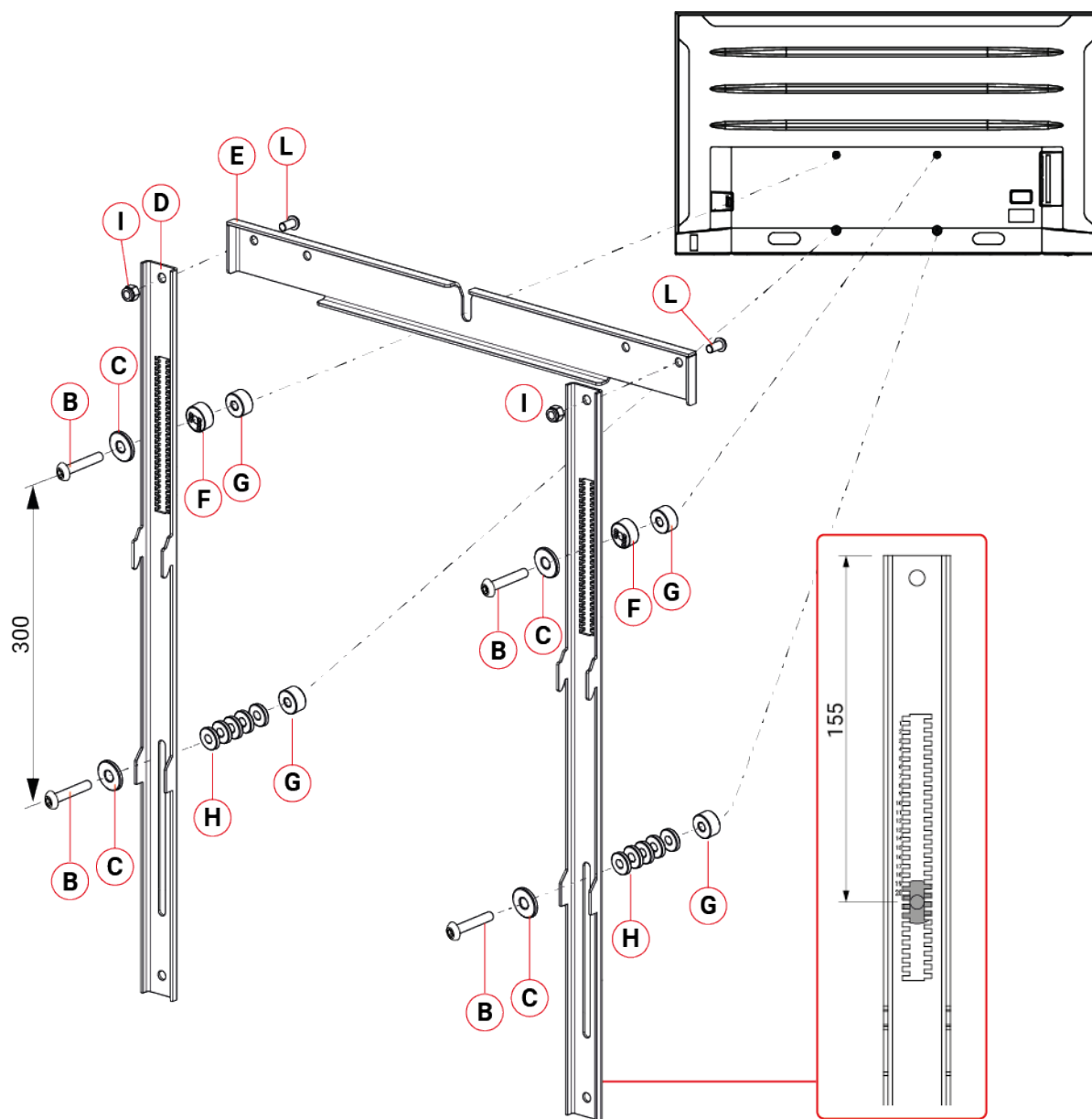

REF.	CODE	DESCRIPTION	Qty.
B	6900307	TBEI M6x30 screw	4
C	6900089	6x18 washer	4
D	3913344	Monitor brackets	2
E	3916134	Monitor tilt bracket	1
F	3913346	Toothed spacer 10 mm	2
G	3913345	Spacer 10 mm	4
H	3913342	Spacer 2 mm	10
I	4150601	M6 self-locking nut	2
L	6900196	TBEI M6x12 screw	2

Fasten the assembled monitor to the RPI-VESA mount.

13.6 Fastening on a HISENSE monitor: 75A7G AUSTRALIA

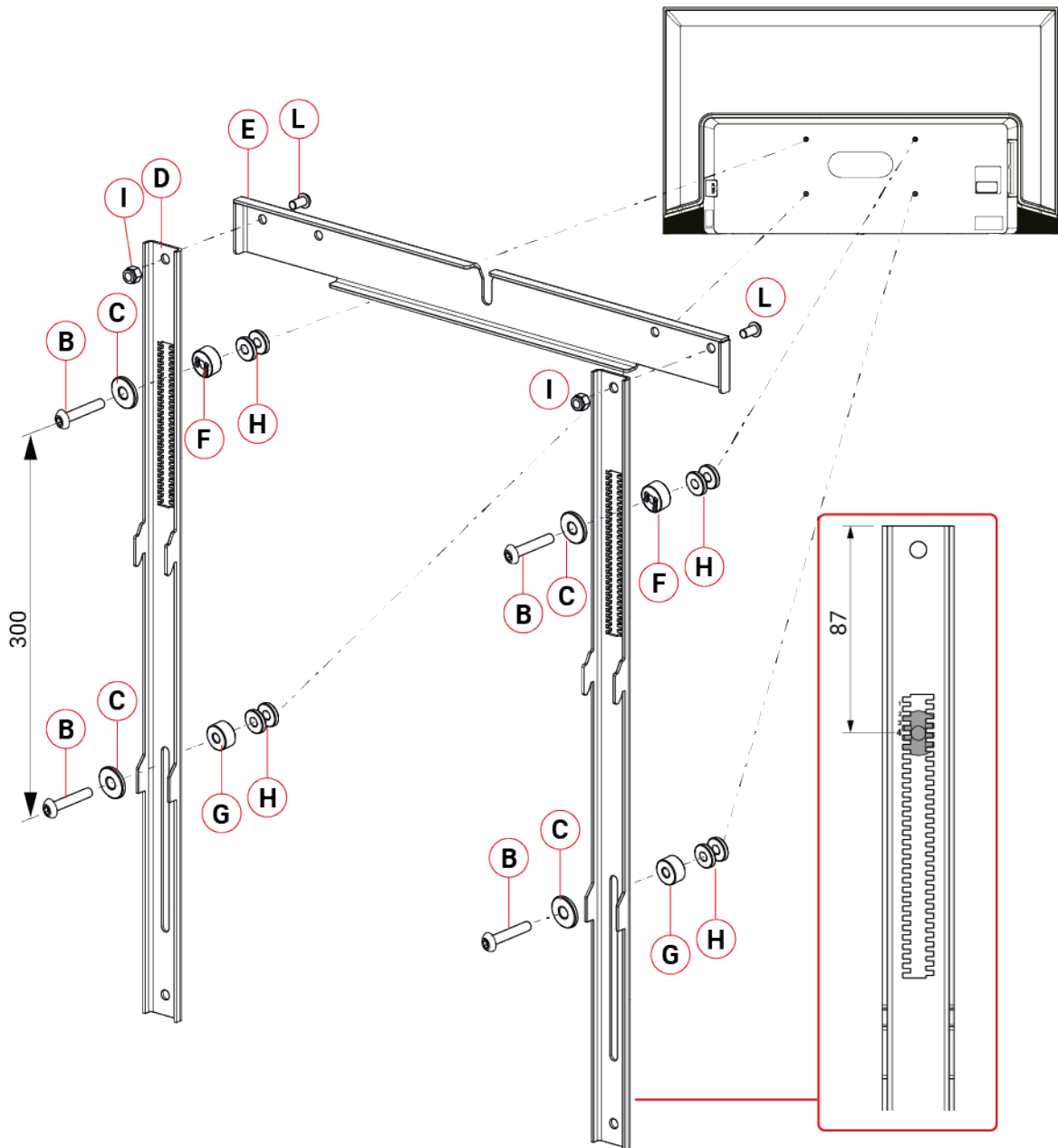

REF.	CODE	DESCRIPTION	Qty.
B	6900307	TBEI M6x30 screw	4
C	6900089	6x18 washer	4
D	3913344	Monitor brackets	2
E	3916134	Monitor tilt bracket	1
F	3913346	Toothed spacer 10 mm	2
G	3913345	Spacer 10 mm	2
H	3913342	Spacer 2 mm	8
I	4150601	M6 self-locking nut	2
L	6900196	TBEI M6x12 screw	2

Fasten the assembled monitor to the RPI-VESA mount.

13.7 Fastening on a HISENSE monitor: 75A7HAU AUSTRALIA

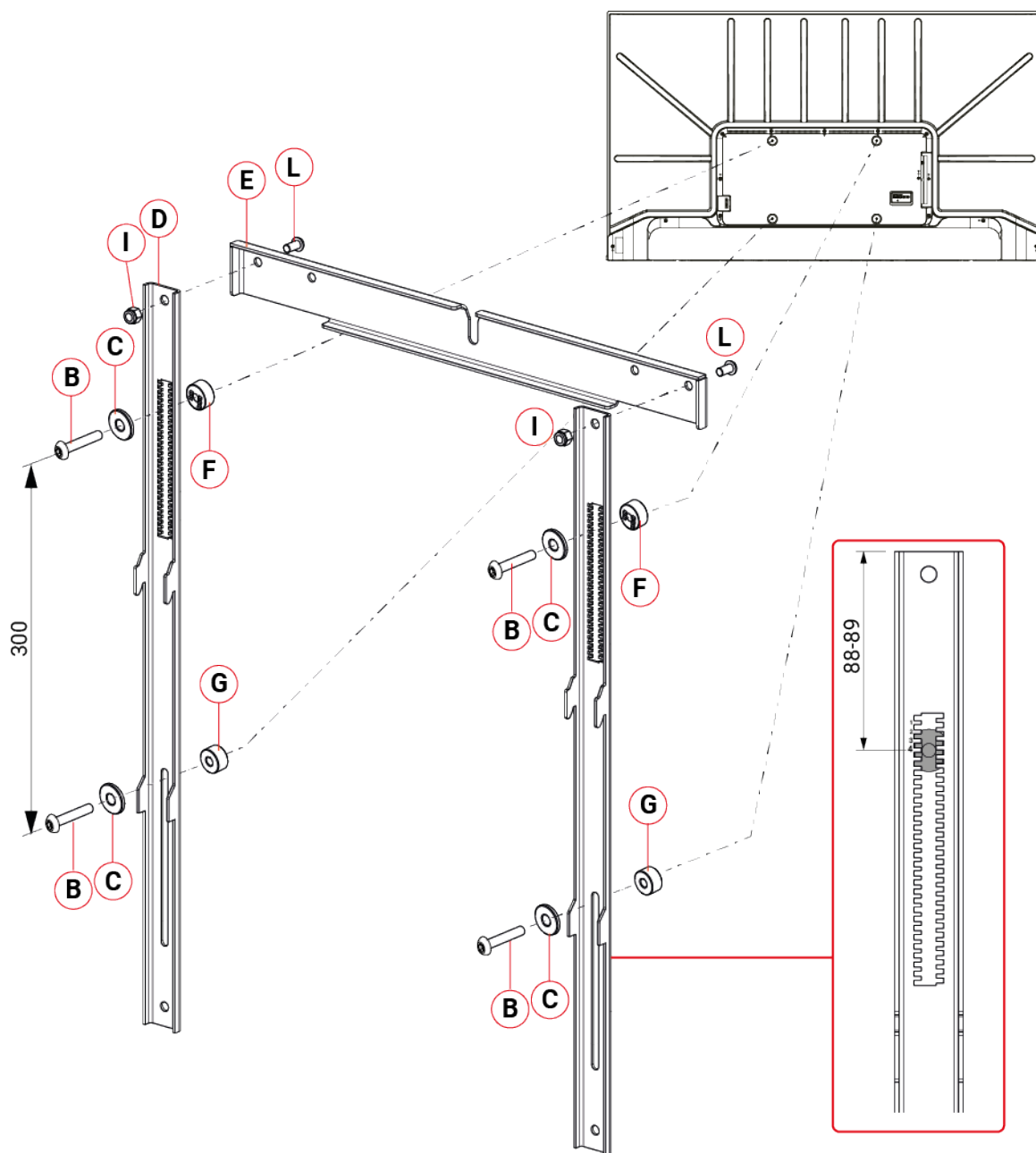

REF.	CODE	DESCRIPTION	Qty.
B	6900307	TBEI M6x30 screw	4
C	6900089	6x18 washer	4
D	3913344	Monitor brackets	2
E	3916134	Monitor tilt bracket	1
F	3913346	Toothed spacer 10 mm	2
G	3913345	Spacer 10 mm	2
H	3913342	Spacer 2 mm	4
I	4150601	M6 self-locking nut	2
L	6900196	TBEI M6x12 screw	2

Fasten the assembled monitor to the RPI-VESA mount.

13.8 Fastening on a HISENSE monitor: 75A6G and 75A6CG NORTH AMERICA

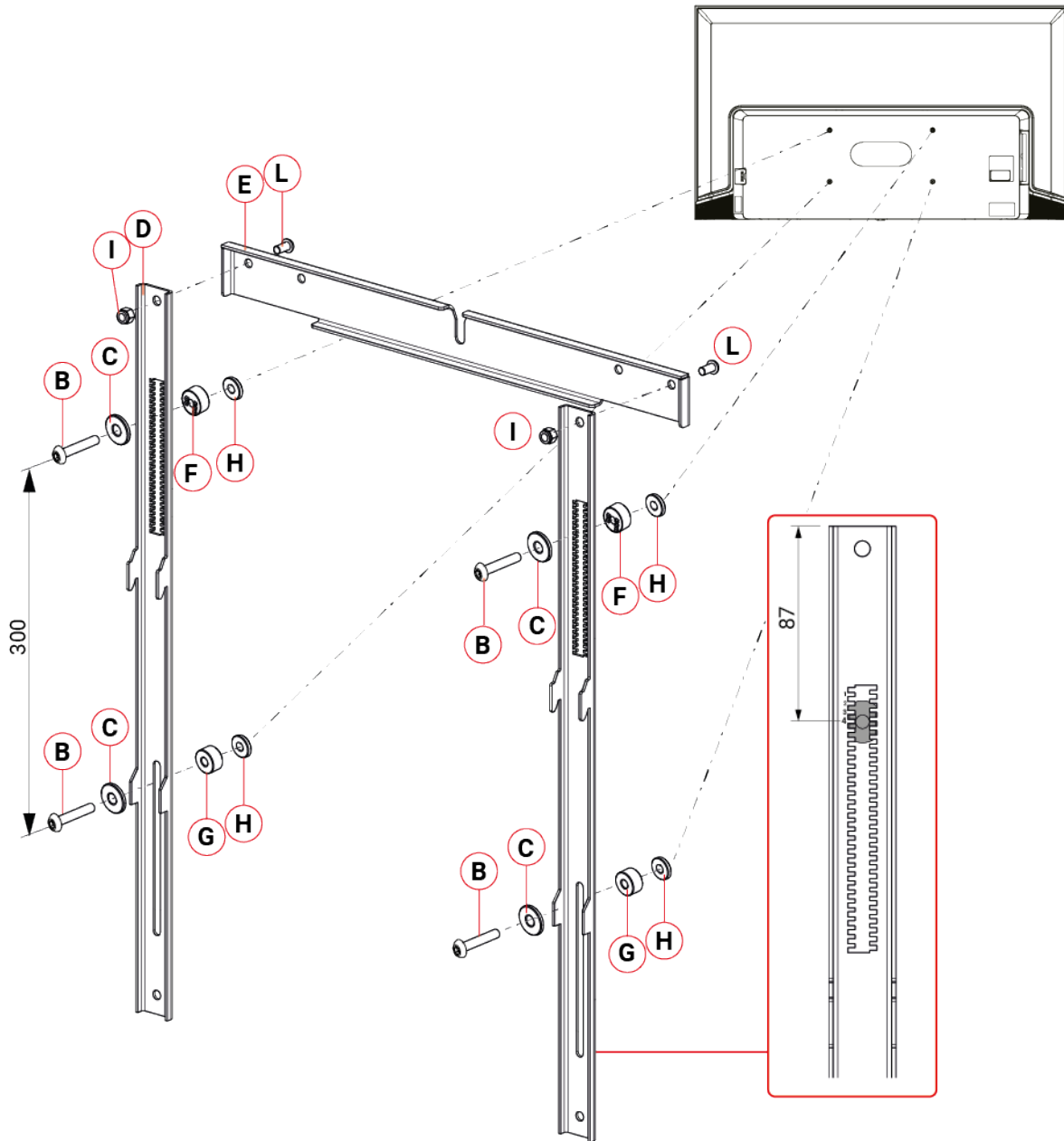

REF.	CODE	DESCRIPTION	Qty.
B	6900307	TBEI M6x30 screw	4
C	6900089	6x18 washer	4
D	3913344	Monitor brackets	2
E	3916134	Monitor tilt bracket	1
F	3913346	Toothed spacer 10 mm	2
G	3913345	Spacer 10 mm	2
I	4150601	M6 self-locking nut	2
L	6900196	TBEI M6x12 screw	2

Fasten the assembled monitor to the RPI-VESA mount.

13.9 Fastening on a HISENSE monitor: 75A6N NORTH AMERICA

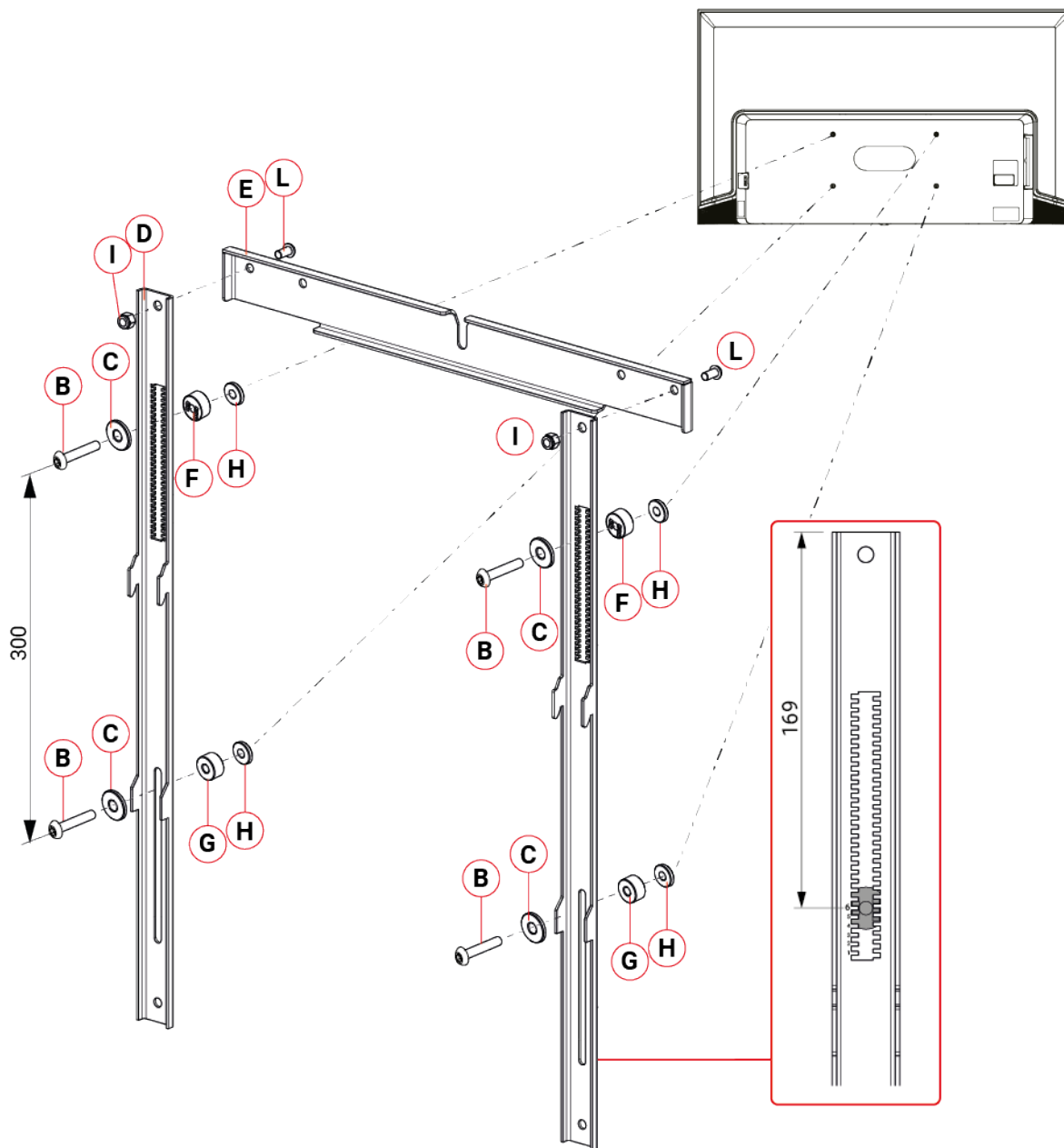

REF.	CODE	DESCRIPTION	Qty.
B	6900307	TBEI M6x30 screw	4
C	6900089	6x18 washer	4
D	3913344	Monitor brackets	2
E	3916134	Monitor tilt bracket	1
F	3913346	Toothed spacer 10 mm	2
G	3913345	Spacer 10 mm	2
H	3913342	Spacer 2 mm	4
I	4150601	M6 self-locking nut	2
L	6900196	TBEI M6x12 screw	2

Fasten the assembled monitor to the RPI-VESA mount.

13.10 Fastening on a SONY monitor: KJ-75X80L JAPAN

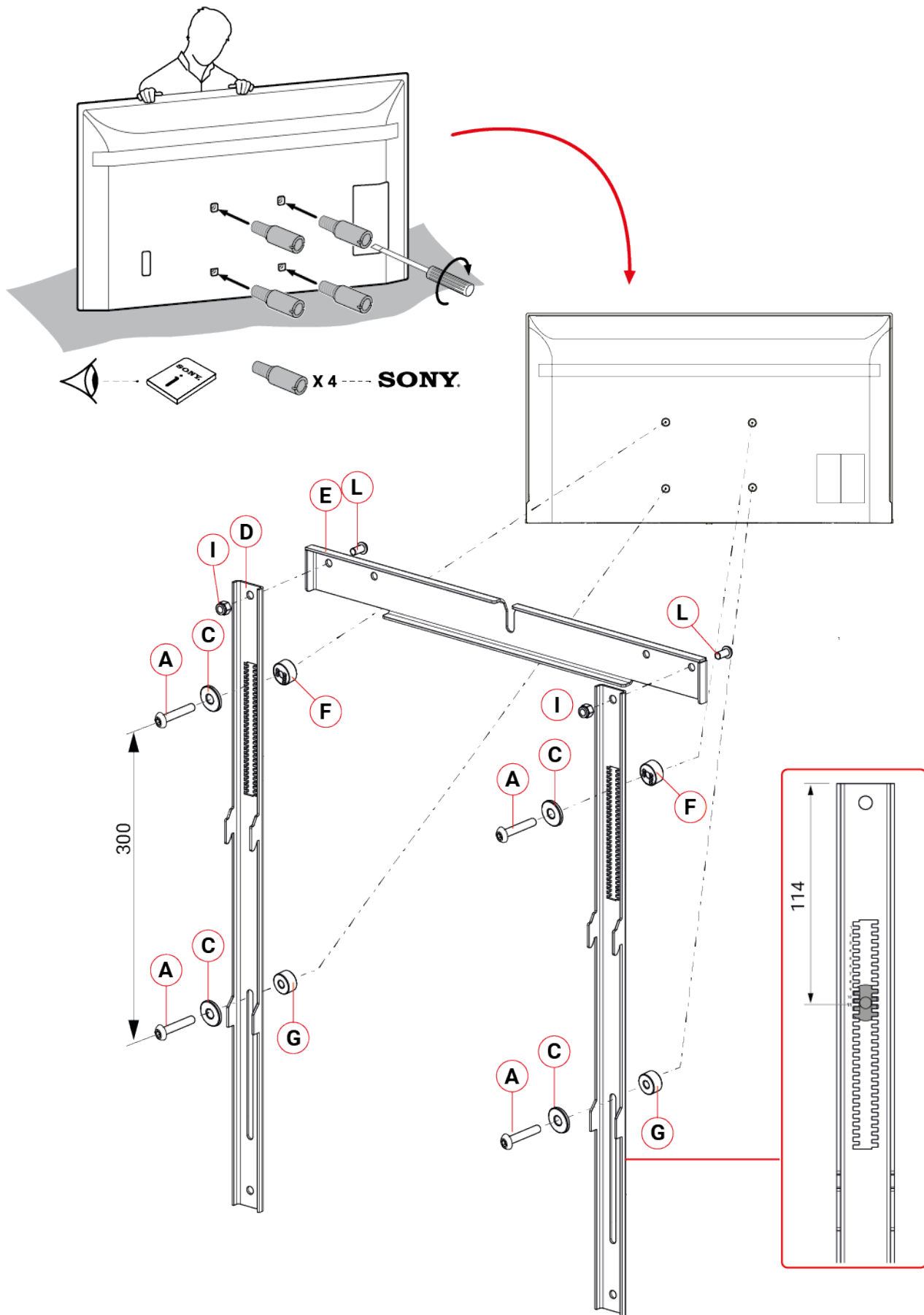

REF.	CODE	DESCRIPTION	Qty.
A	6900396	TBEI M6x25 screw	4
C	6900089	6x18 washer	4
D	3913344	Monitor brackets	2
E	3916134	Monitor tilt bracket	1
F	3913346	Toothed spacer 10 mm	2
G	3913345	Spacer 10 mm	2
I	4150601	M6 self-locking nut	2
L	6900196	TBEI M6x12 screw	2

Fasten the assembled monitor to the RPI-VESA mount.

CAUTION

When first switched on, the Sony monitor KJ-75X80L must be configured.

Configure the monitor before connecting it to the mini-PC.

For further information see the **MONITOR SETTING ADJUSTMENTS FOR RCCS 3 EVO** chapter.

14 POWER SUPPLY

The motorised workstation and the mini-PC are powered by the mains through supplied external power adapters.

CAUTION

The use of different power adapters other than the ones supplied can damage the equipment and expose the operator to the risk of injuries.

If the equipment is not used as specified by the manufacturer, the protection provided by the equipment may be altered.

The mains plug must be used to disconnect from the mains.

Do not position the equipment so that it becomes difficult to disconnect it from the mains.

Only use the supplied power adapters.

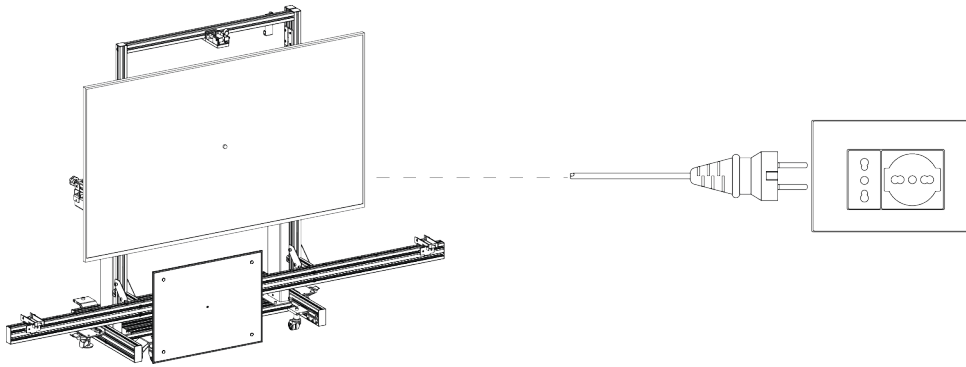

Proceed as follows:

1. Connect the power cable's plug to the mains.

INFORMATION

In RCCS 3 EVO, the power adapters are connected to the power strip.

The monitor is connected directly to the power strip.

NOTICE

The power strip must be used to power only the following items:

- motorised workstation
- mini-PC
- monitor

Do not connect any other type of device to the power strip.

15 RCCS 3 EVO UNIT ADJUSTMENTS

This chapter provides the basic indications for the unit's fine-tuning.

After installing the monitor and before moving the unit, you can:

- *check the unit's stability by adjusting the levelling feet with brakes;*
- *check and adjust the plate holder bar installation height;*
- *calibrate the calibration plate;*
- *adjust the line laser;*
- *adjust the workstation horizontally.*

15.1 Levelling foot adjustment

Before proceeding with any type of calibration on the vehicle, make sure the unit is firmly locked to the ground.

For this purpose, the unit is equipped with two levelling feet with brakes.

Proceed as follows:

1. Actuate the foot's brake by pressing the DOWN lever.
2. Make sure the unit is stable, locked to the ground and not lifted.
3. If the unit appears to be lifted or not firmly locked to the ground, act on the nuts at the base of the foot.

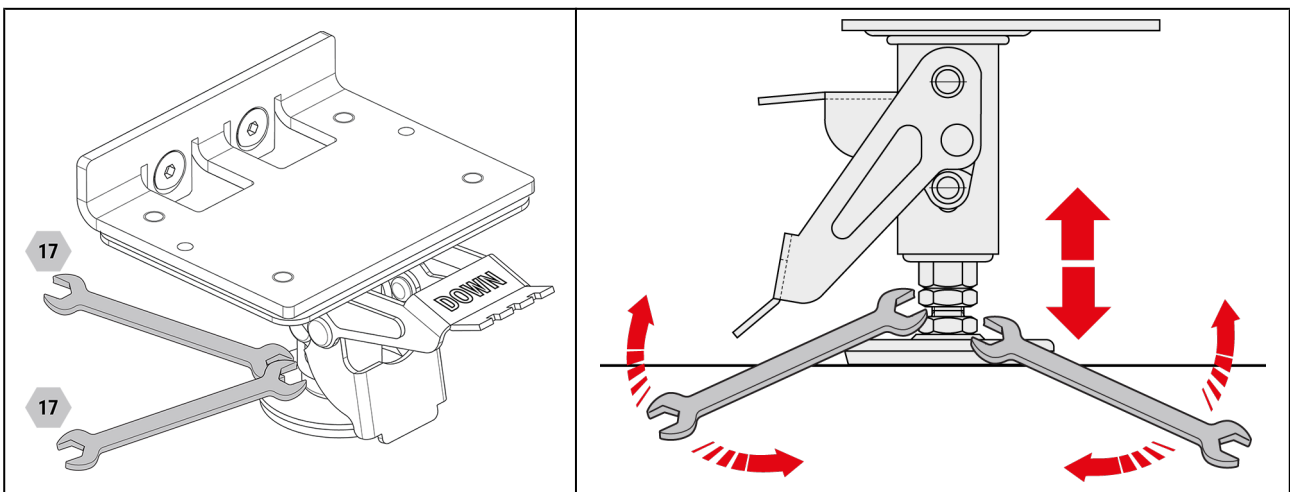

⚠ CAUTION

The feet must guarantee the unit's stability.

The feet must not lift the unit excessively and must firmly touch the ground.

15.2 Calibration plate holder bar adjustment

Based on the model of vehicle to calibrate, the plate holder bar can be set to two different height levels.

The bar is preferably installed in the highest position, as indicated in the assembly video.

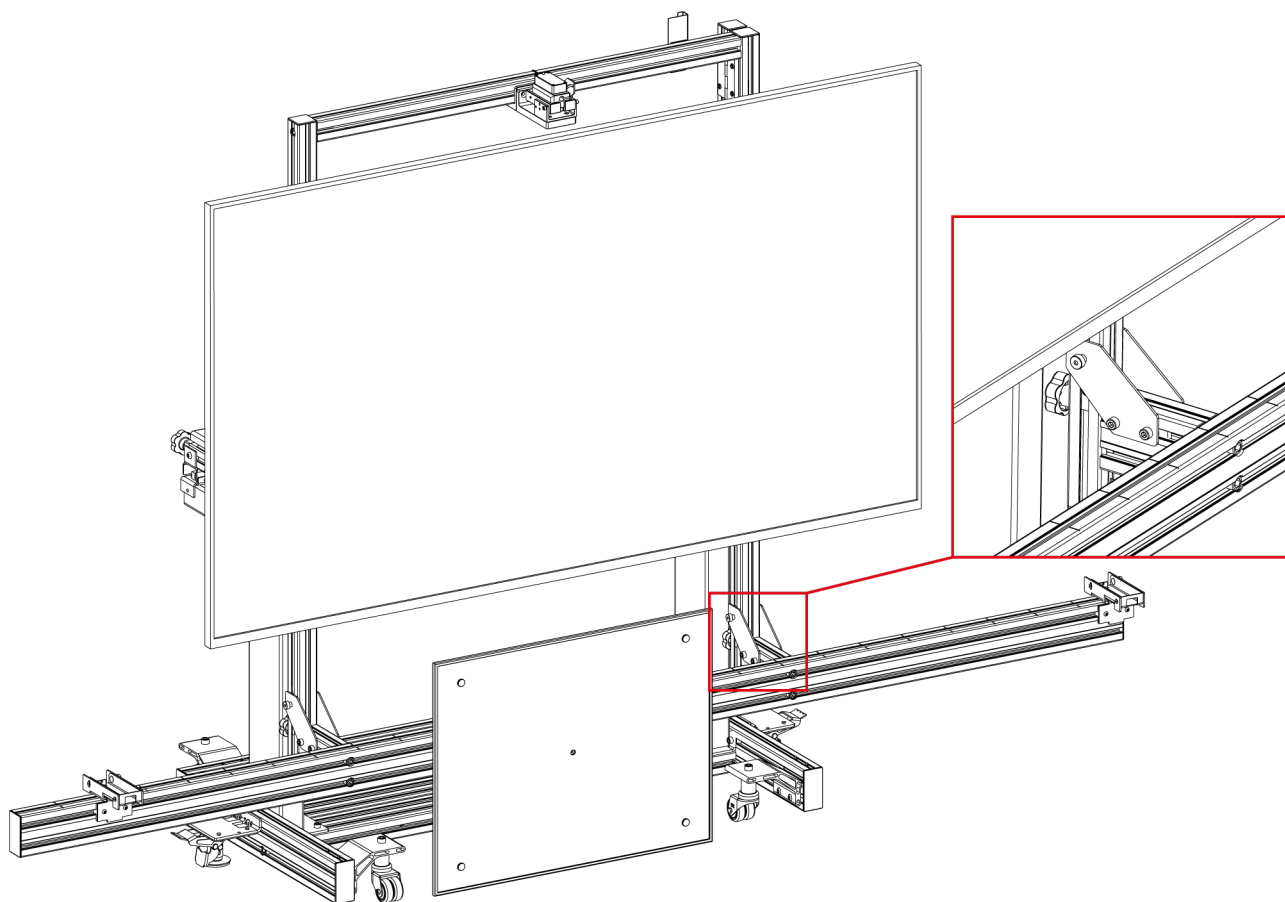

⚠ WARNING

The adjustment of the plate holder bar requires at least two people.

The unit must be assembled by qualified personnel.

The personnel in charge of the assembly must wear suitable safety equipment at all times during the assembly.

NOTICE

There must not be any accessory (e.g.: plate, laser measurer brackets) installed on the plate holder bar, so to adjust it with the utmost safety.

To change the bar assembly position, proceed as follows:

1. Clear the bar of any unnecessary element that may prevent its movement.
2. The operation must be carried out by at least two people.
3. Unscrew the knobs behind the bar holder profiles, without removing them.
4. Unhook the bar by lifting it.

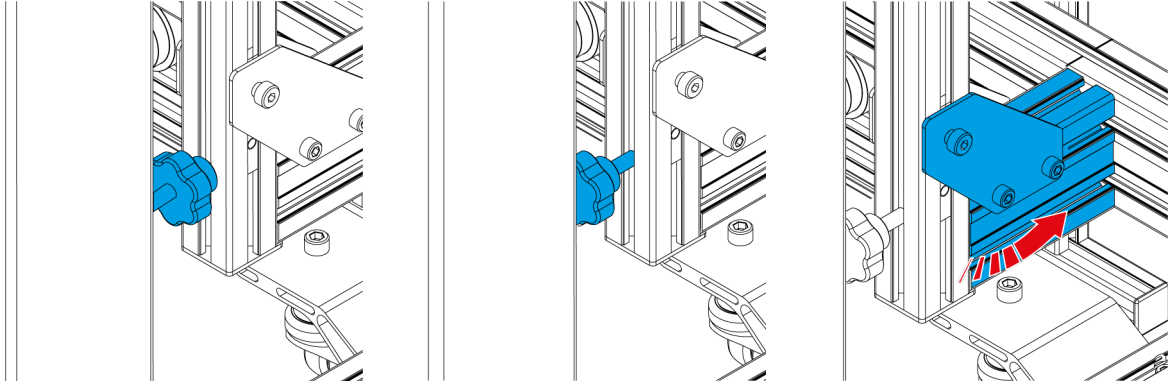

5. Lower the bar until you reach the base of the vertical columns and lock it.

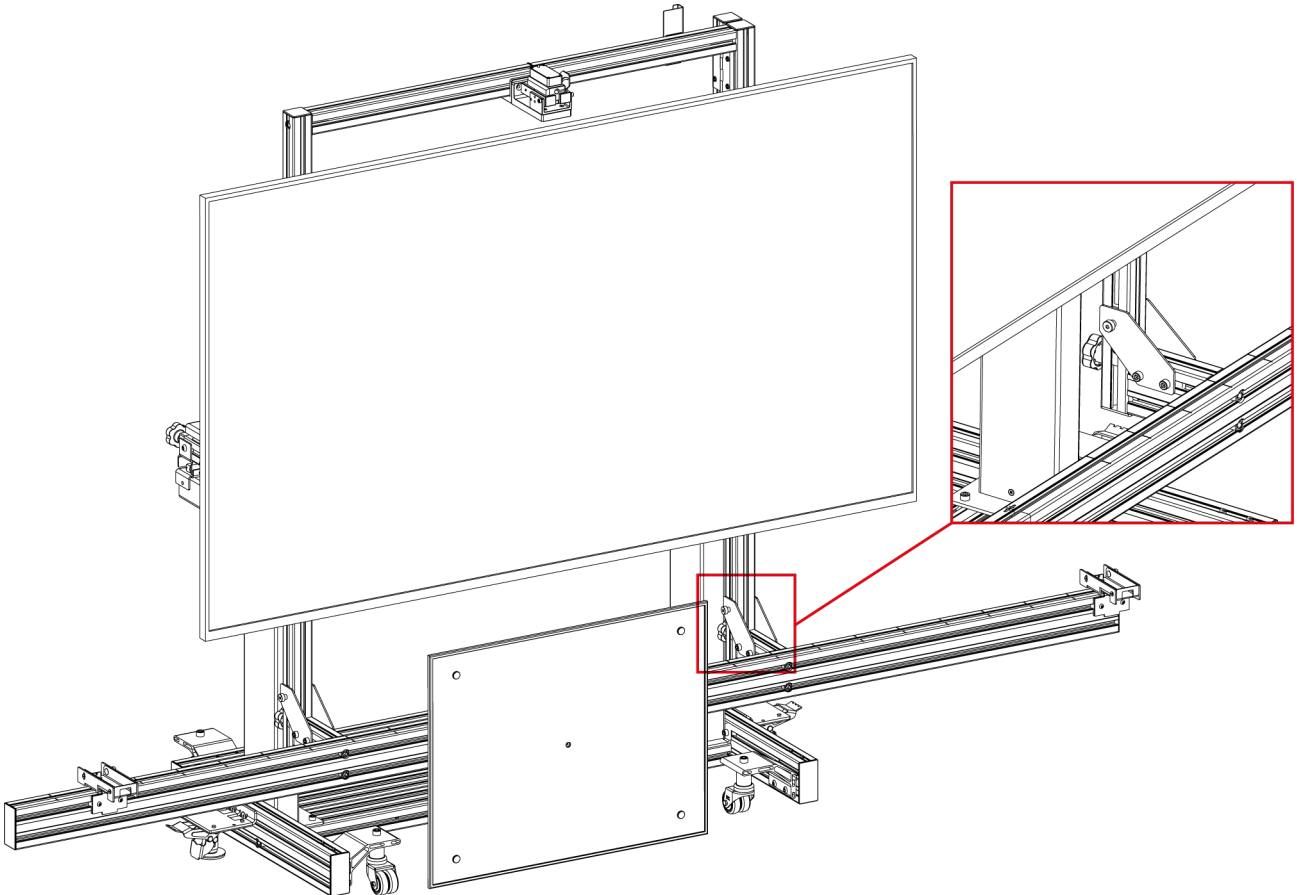

15.3 Calibration procedure

Once the unit assembly is complete, you must carry out a calibration procedure on the calibration plate.

The calibration must be carried out with the radar calibration plate installed.

Proceed as follows:

1. Check the calibration of the digital level.

Proceed as follows:

- a) Position the digital level on a flat surface and press the ON/OFF and ZERO buttons simultaneously until the symbol "-1-" appears in the display.
- b) Press the ON/OFF button. The symbol "-1-" will flash briefly, and soon after that the symbol "-2-" will appear in the display.
- c) Rotate the digital level by 180° and press the ON/OFF button. The symbol "-2-" will start flashing briefly.
- d) When the symbol "-2-" stops flashing, the level calibration is complete.

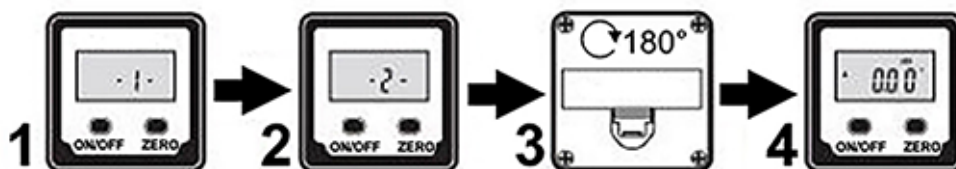

CAUTION

The digital level must be calibrated periodically, as it is a precision tool.

The calibration will delete the "RELATIVE ZERO" setting (related to the working surface tilt).

Set the "RELATIVE ZERO" again before moving on to the calibration procedure for the calibration plate.

2. Clean the calibration plate thoroughly with a cloth and check the digital level support bases.

3. Lay the level against the plate, at the upper left, in the centre of the label.

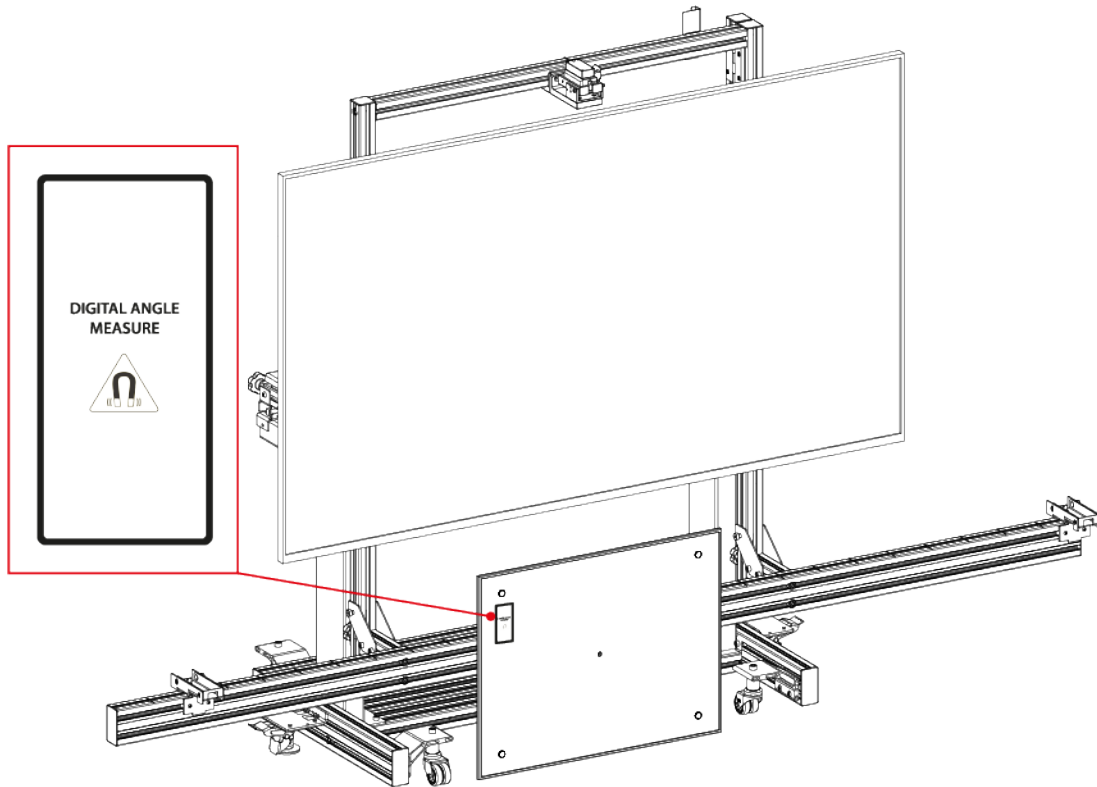

The value indicated by the level must be 90° , with the plate selector in position 0.

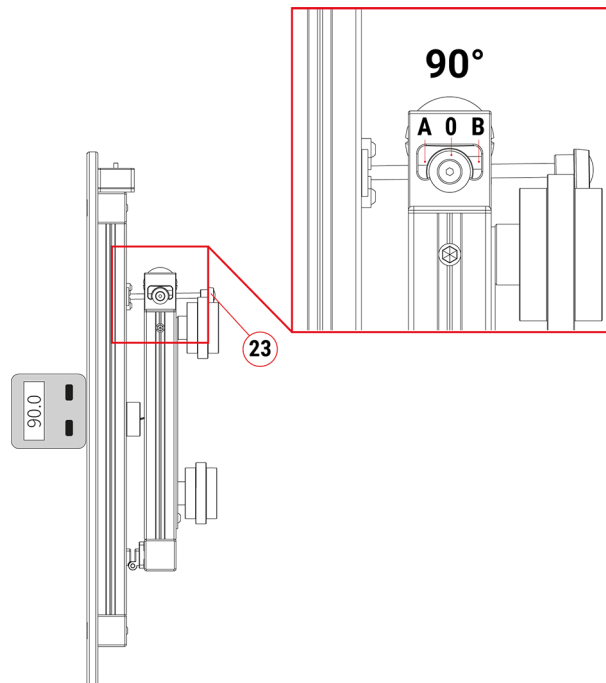

4. Turn the adjustment knob [23] until a value of 90° can be read on the level display, if necessary.

NOTICE

The mutual positioning of the level mounting bracket and calibration plate must be checked periodically and/or whenever the working area is changed.

15.4 Monitor adjustment

The monitor tilt can be adjusted by acting on the monitor tilt adjustment knob.

Turn the knob clockwise or counterclockwise until the monitor is exactly perpendicular to the ground (90°).

A digital level is supplied with the unit in order to check the monitor's levelling.

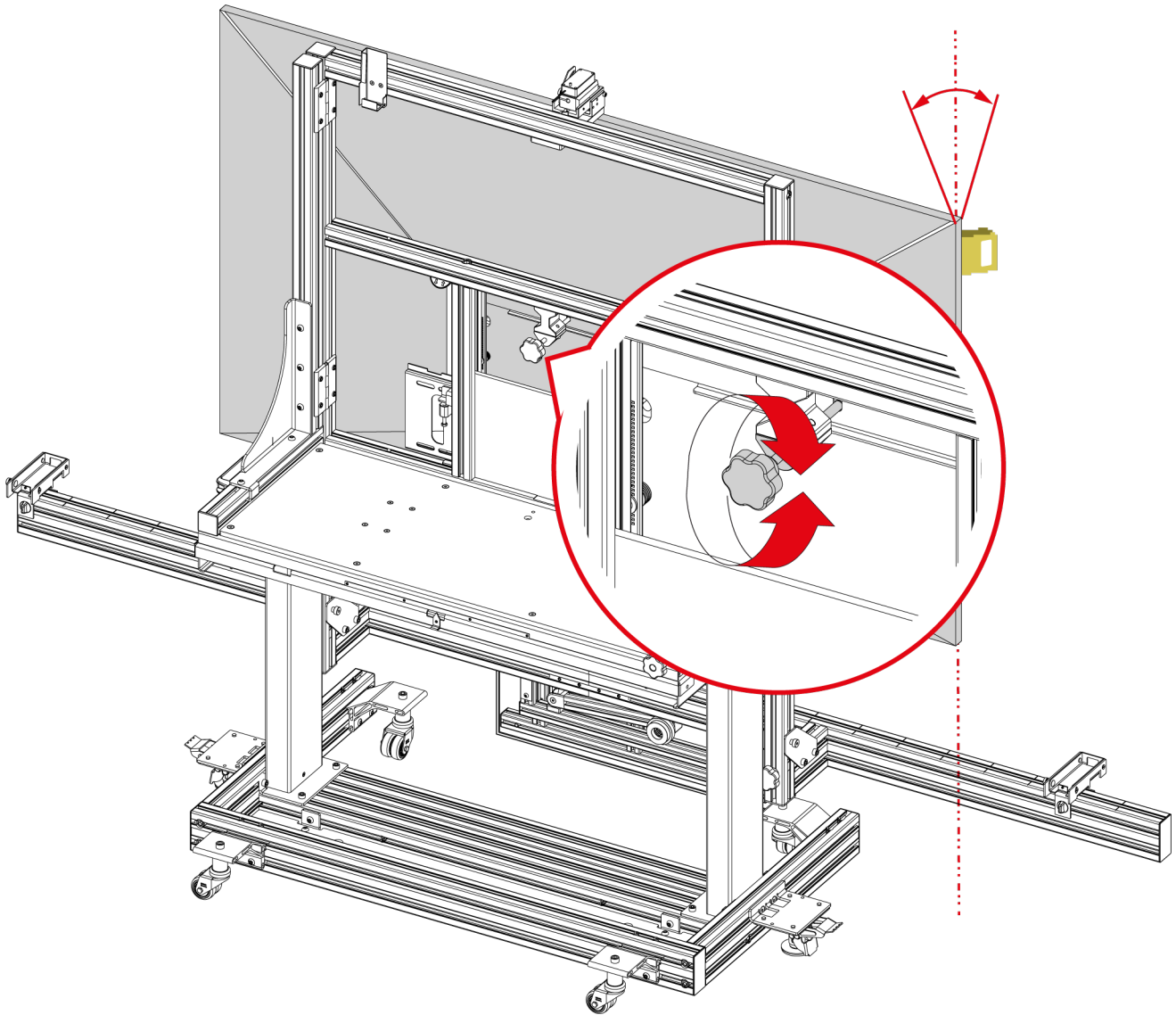

Moreover, the monitor tilt can be adjusted by acting on the screws behind the monitor itself. Turn the screws alternately clockwise or counterclockwise until you find the correct tilt required.

CAUTION

We recommend acting on one screw at a time.

A simultaneous adjustment may cause severe damage to the monitor.

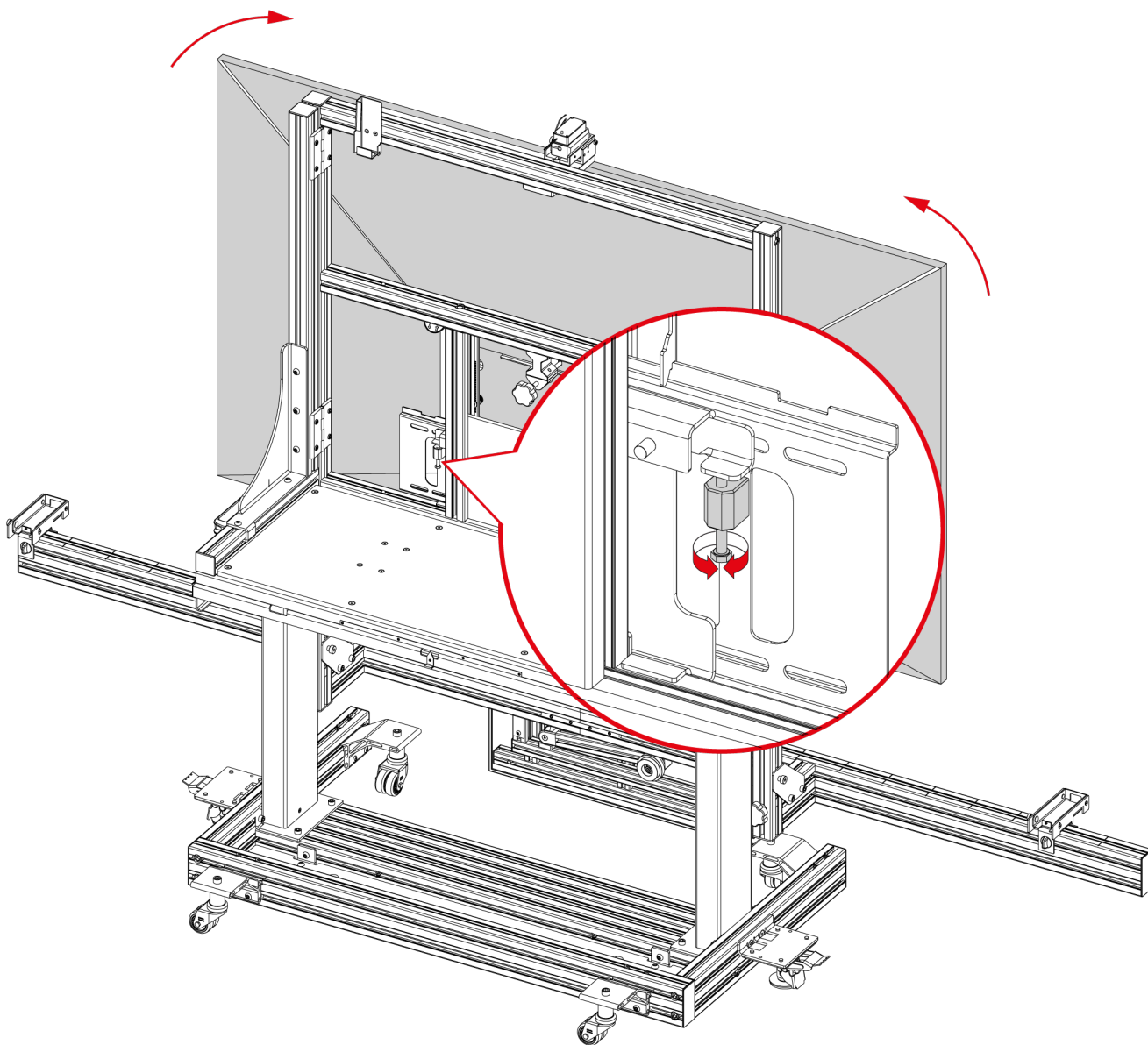

15.5 Line laser bracket installation and adjustment

The line laser is required to highlight the vehicle's centre.

The line laser bracket must be positioned on the upper crossbeam of the unit.

Proceed as follows:

1. Fasten the line laser bracket on the crossbeam with the supplied screws, being careful to the proper alignment with the dowel pin.

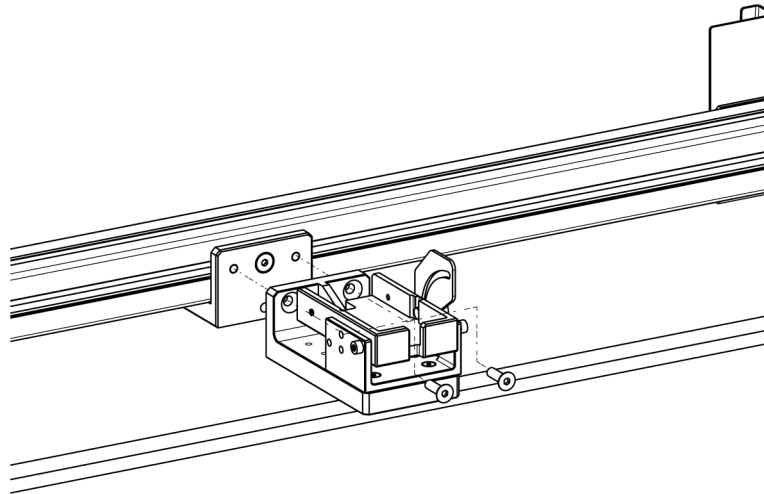

2. Tilt the bracket by acting on the adjustment knob on the side of the bracket itself.

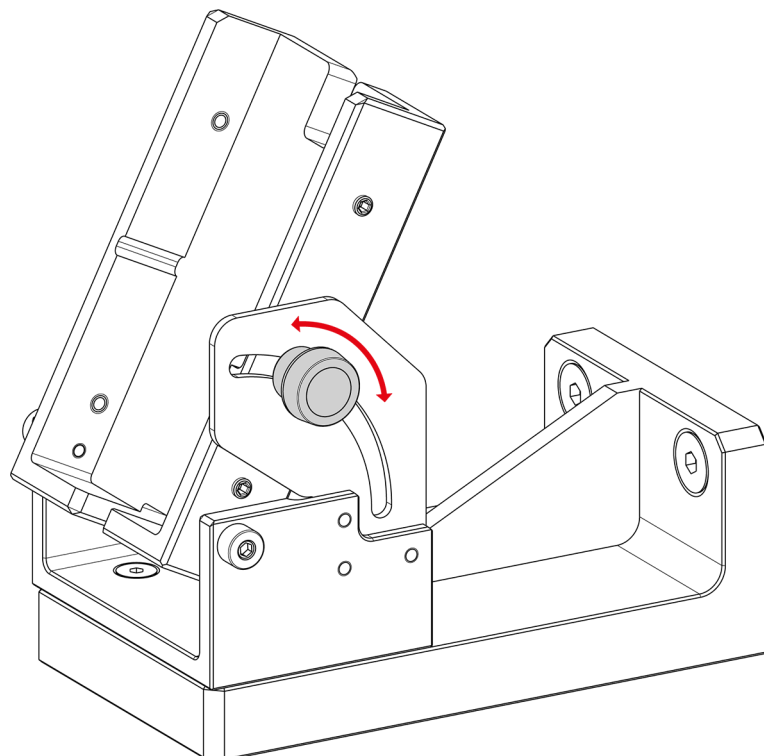

3. Place the line laser on its support.
4. Lock the line laser to the support with the "hex head" screws located on the side.

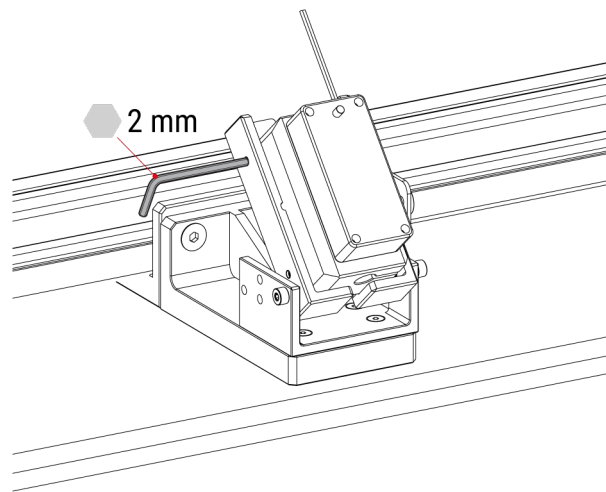

5. Place the workstation in the position "0" (zero). See the metric line in front of the workstation. The laser beam must pass through the monitor's and plate holder bar's centre.

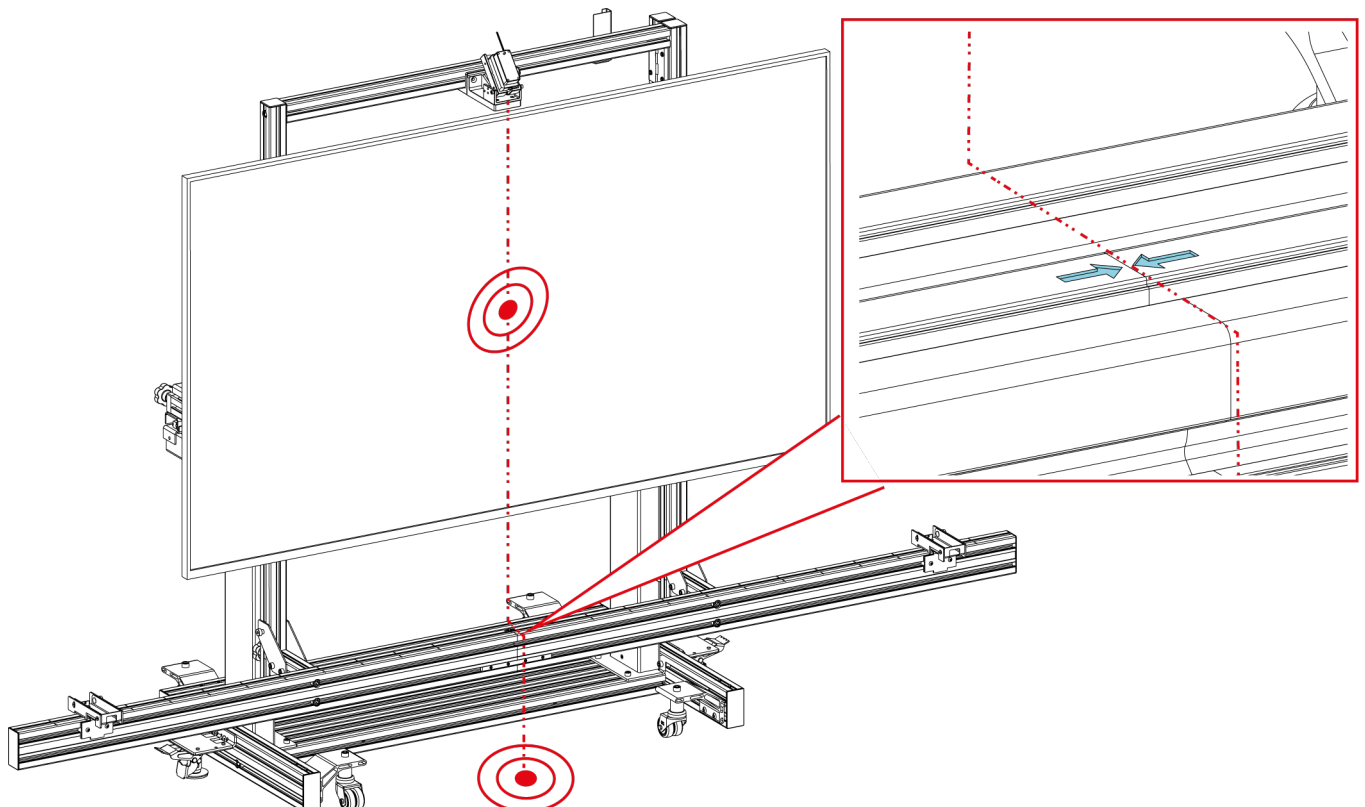

15.6 Horizontal adjustment of the workstation

It is possible to adjust the horizontal position of the workstation, moving it to the right or to the left.

This adjustment must ONLY be carried out when requested by the software and/or diagnostic sheet within the radar/camera calibration procedure.

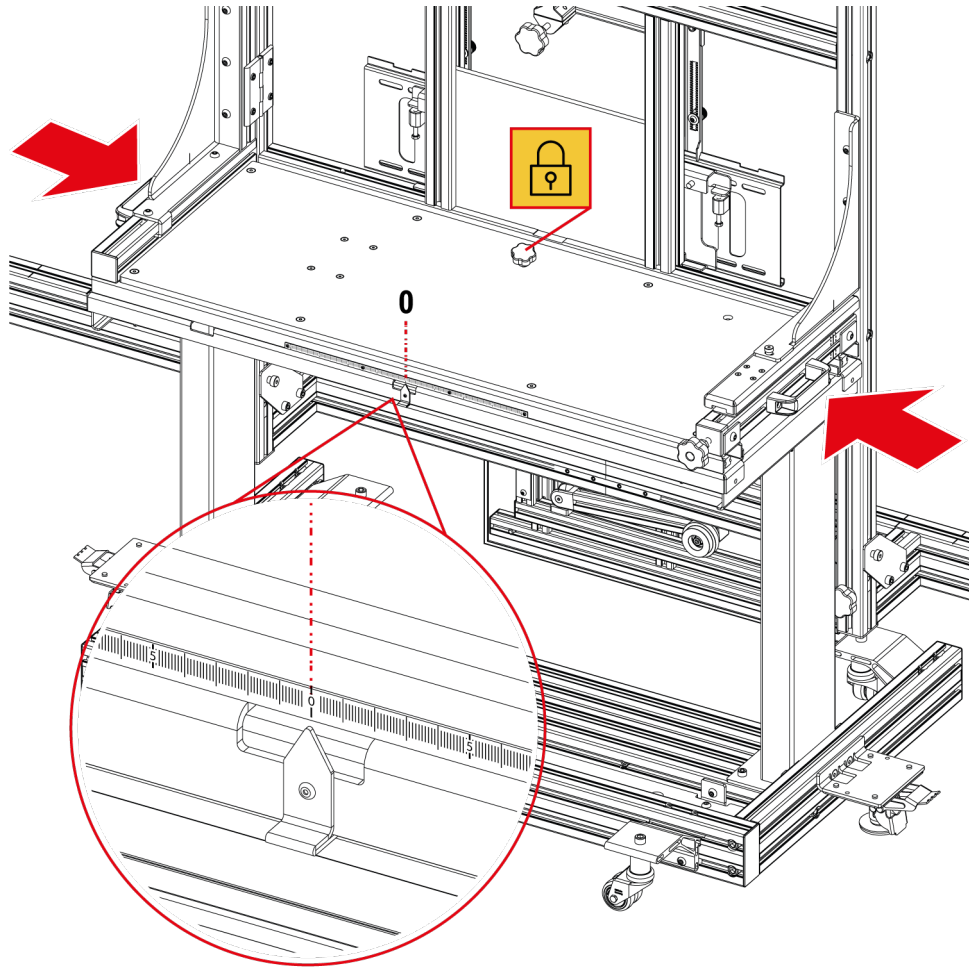

Make sure you unlocked the workstation using the knob on it, and proceed with the adjustment required by the software and/or diagnostic sheet.

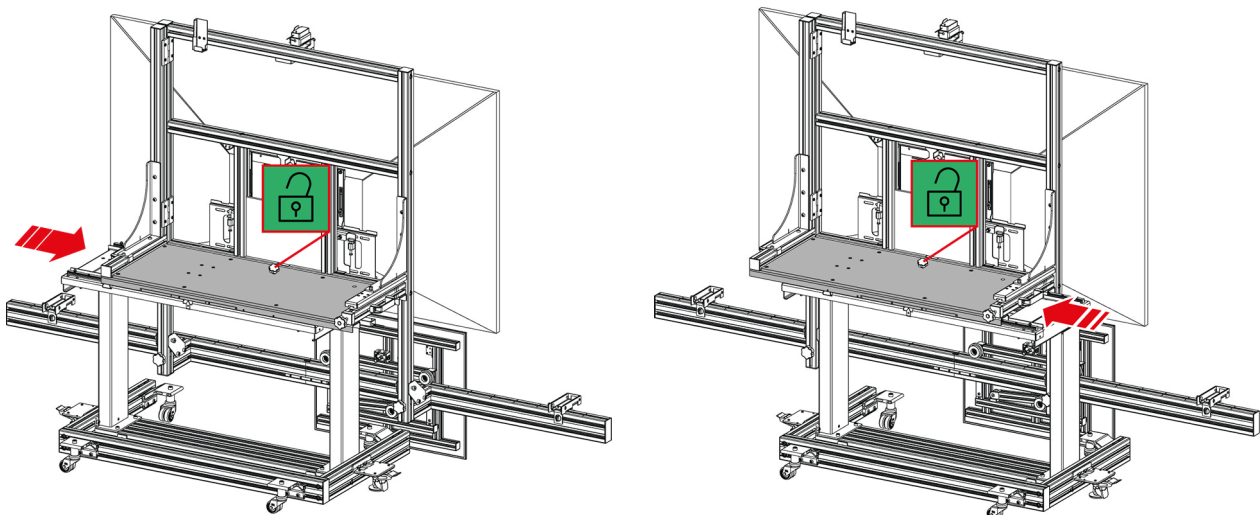

16 POWER ON/OFF

The motorised workstation and the mini-PC will turn on automatically once the power cable is connected to a mains socket.

To turn on the monitor, press the specific button.

The position of the button may vary based on the model of the monitor supplied:

- A) *bottom left part of the frame*
- B) *bottom central part of the frame*

All the models ensure the performance required to carry out the calibration procedures properly and effectively.

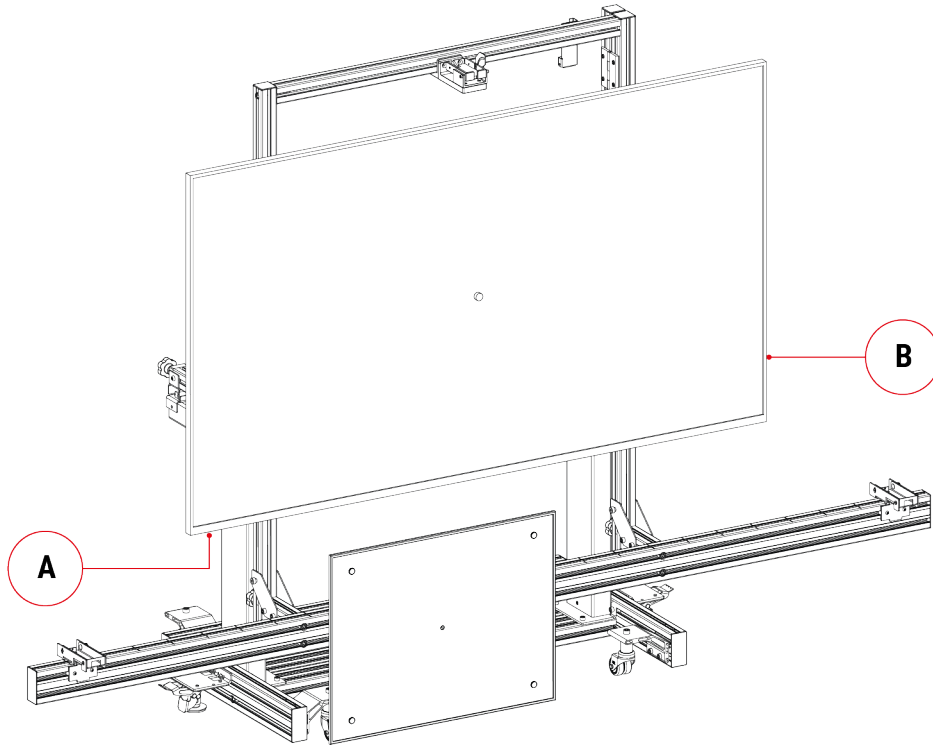

For further information consult the monitor's operating manual.

To turn off, proceed as follows:

1. *Press and hold the specific button on the monitor until it turns off.*
2. *Disconnect the power cable from the mains.*

NOTICE

Turning off in other ways rather than the ones indicated may damage the devices.



16.1 Standby

If the HDMI-CEC controls are enabled on the monitor, the mini-PC will be able to control the monitor's wake-up and standby.

INFORMATION

The mini-PC and the monitor must be powered.



For further information on the activation of the HDMI-CEC controls and the standby timeout setting (recommended 15 minutes), please refer to the monitor's manual.

17 MINI-PC

Thanks to the mini-PC fitted on **RCCS 3 EVO**, you can use a display unit to send the high-resolution image of the panel required for the calibration to the monitor mounted on the unit. The connection between the mini-PC and the display unit takes place via Bluetooth.

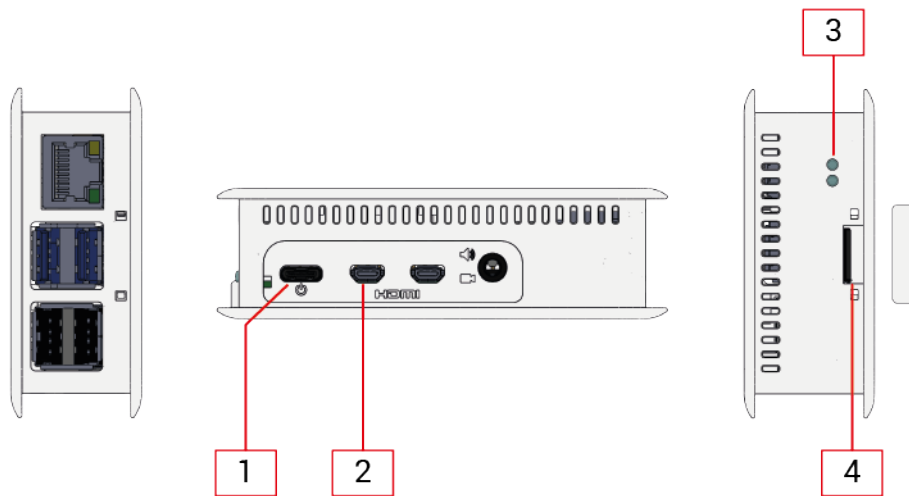

- *USB-C (mini-PC power supply)*
- *Micro HDMI*
- *LED*
- *Slot micro SD*

INFORMATION

All the connectors that are not mentioned are disabled.

The mini-PC is provided with a special micro SD card already inserted in the specific slot. The micro SD card is the only mass storage device in the mini-PC, it contains the operating system and several other files required for the equipment to operate properly.

INFORMATION

The micro SD card and the mini-PC are 'paired' univocally, which means it is not possible to use micro SD cards other than the one supplied with the mini-PC unless they are specifically provided by the Technical Assistance.

The mini-PC is equipped with two LEDs, through which it communicates its status:

LED		Status
Red	OFF	mini-PC off
	ON	powered mini-PC on
Green	OFF	no activity on the micro SD card
	ON	activity on the micro SD card (reading/writing)

NOTICE

Do not remove and/or replace the micro SD card unless expressly indicated by the Technical Assistance.

Removing the micro SD card while the mini-PC is working may compromise its proper operation.

For further information, contact your retailer.

18 COMMUNICATION

The mini-PC and laser distance measurers supplied with **RCCS 3 EVO** are equipped with a Bluetooth module that allows the wireless connection to a display unit.

This way, the display unit can transmit the image of the panel that must be used for the calibration to the mini-PC, which in turn transmits it to the monitor and checks the proper positioning of the unit with respect to the vehicle at issue.

In order for this to be possible, you must configure the communication between the Bluetooth devices supplied with the unit and the display unit.



For further information on the configuration and use of the Bluetooth devices see the software operating manual.

INFORMATION

To configure the communication properly, you must use the serial number indicated on the TEXA data plate on the motorised workstation.

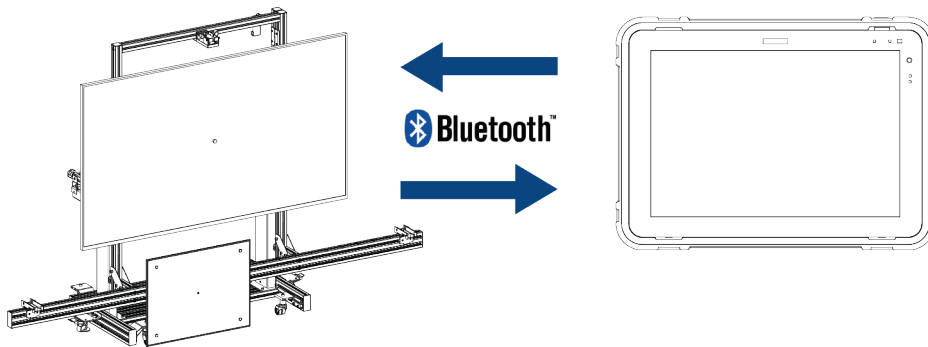

Proceed as follows:

1. *Power the mini-PC.*
2. *Turn on the laser distance measurers.*
3. *Turn on the display unit.*
4. *Access the communication configuration functions.*
5. *Follow the on-screen instructions.*



For further information, see the software operating manual.

18.1 Configuration of the Bluetooth laser distance measurers

To configure the **RCCS 3 EVO** unit and the Bluetooth laser distance measurers, you must access the Configuration Wizard menu in the **IDC5** diagnostic software.

Proceed as follows:

1. Press 

The screen for entering the information is displayed.

2. Enter the required information in the specific fields.

3. Press 

Wait for the search for devices to complete.

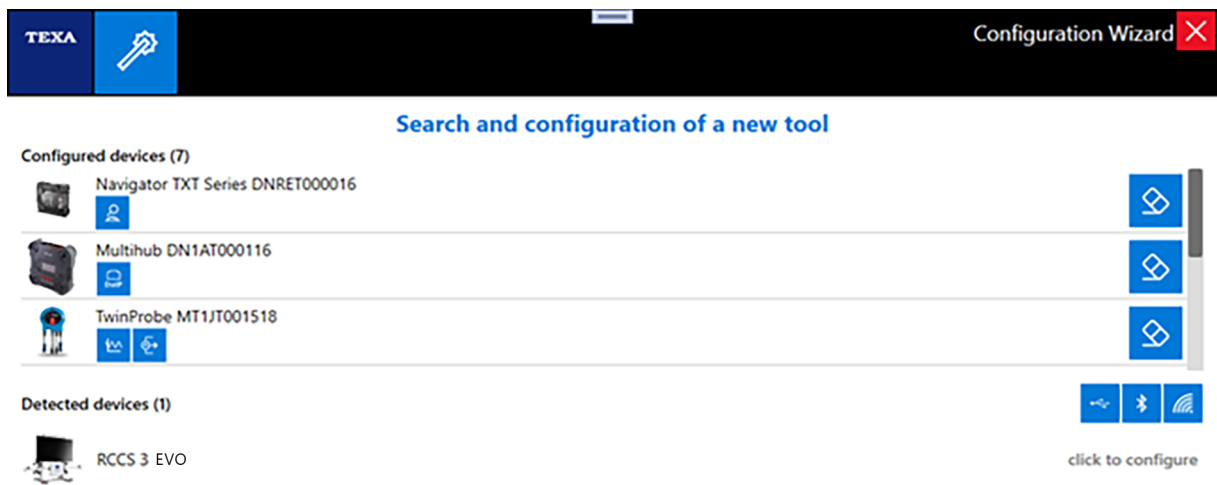

4. Select the device among the ones configured.



RCCS 3 EVO



The tool just configured will be available through these interfaces:



Bluetooth



5. Proceed with the configuration of the **three** Bluetooth laser distance measurers.
The positioning of the laser distance measurers is established by looking at the unit frontally from the calibration panel.
MAKE SURE ALL THE LASER DISTANCE MEASURERS ARE OFF.
6. Turn on the left distance measurer by pressing the ON button.



RCCS 3 EVO

Bluetooth accessory configuration

Automatic configuration with 2 Bluetooth distance measurers in progress...

Turn on the Bluetooth distance measurer you want to position on the left

ATTENTION! Make sure only the Bluetooth distance measurer to configure is turned on.

Press next to start the search



7. Wait for the configuration to complete.



RCCS 3 EVO

Bluetooth accessory configuration

Automatic configuration with 2 Bluetooth distance measurers in progress...

Disto™ D1 detected 11045611

Attach the label 'LEFT' on the tool

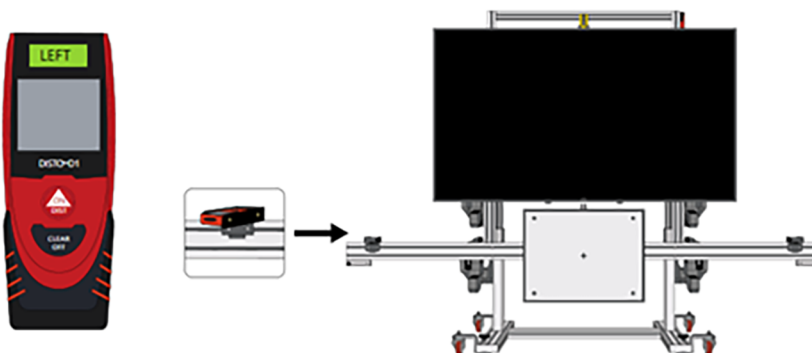

8. Press →

9. Apply the **LEFT** label on the distance measurer.
10. Turn off the left distance measurer **by pressing and holding** the OFF button.
11. Turn on the right distance measurer by pressing the ON button.

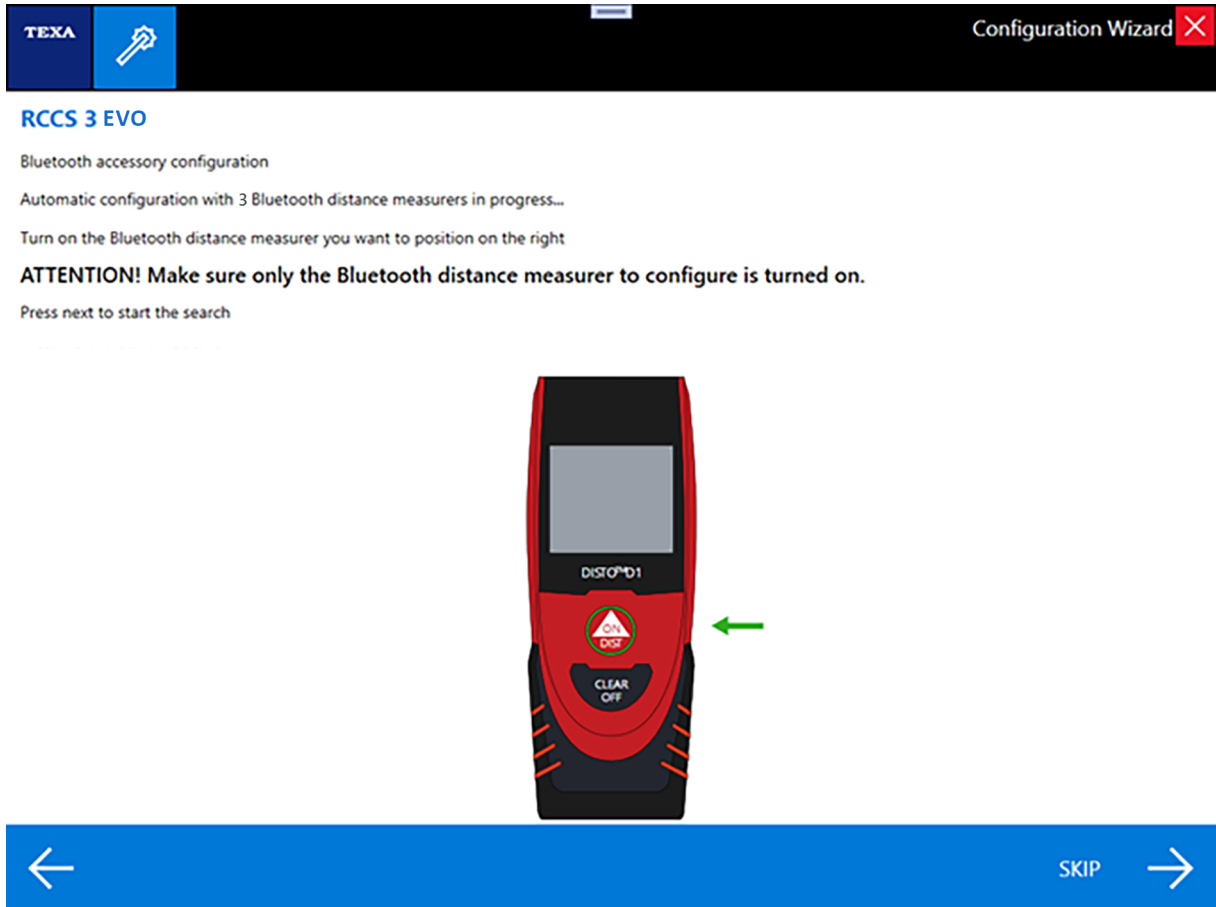

12. Wait for the configuration to complete.



RCCS 3 EVO

Bluetooth accessory configuration

Automatic configuration with 2 Bluetooth distance measurers in progress...

Disto™ D1 detected 11045611

Attach the label 'RIGHT' on the tool

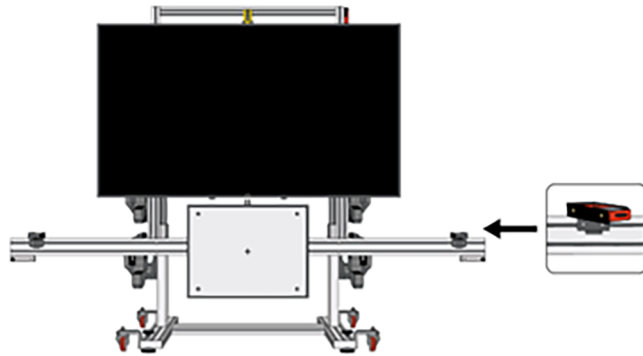

SKIP



13. Press
14. Apply the **RIGHT** label on the distance measurer.
15. Turn off the right distance measurer **by pressing and holding** the OFF button.
16. Turn on the upper distance measurer by pressing the ON button and wait for the configuration to complete.



RCCS 3 EVO

Bluetooth accessory configuration

Automatic configuration with 3 Bluetooth distance measurers in progress...

Attach the label 'UP' on the tool

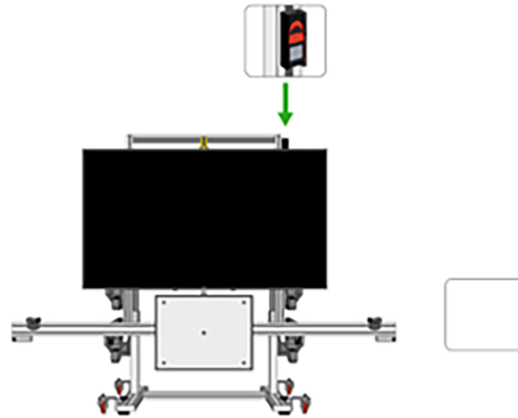

SKIP



17. Press

18. Apply the **UP** label on the distance measurer.

19. Turn off the distance measurer **by pressing and holding** the OFF button.



RCCS 3 EVO

Bluetooth accessory configuration

Current configuration:

'LEFT' distance measurer

'RIGHT' distance measurer

Distance measurer positioned on top of the 'UP' unit

AUTOMATIC 3 DISTANCE MEASURERS

11045611

11045611

11045611



Configure another tool

End the configuration



20. Press



19 MONITOR SETTING ADJUSTMENTS FOR RCCS 3 EVO

After properly fastening the monitor to the unit, carry out the connections required for the setup.

Connect the unit to the mains as indicated in the Power Supply chapter.

To connect the mini-PC to the monitor, proceed as follows:

1. Connect the micro HDMI connector to the HDMI port on the mini-PC.
2. Connect the HDMI connector to the HDMI port 1 on the monitor.
3. Enable the HDMI-CEC controls and the standby timeout settings on the monitor.

NOTICE

Make sure the mini-PC is always connected to the monitor's HDMI 1 port.

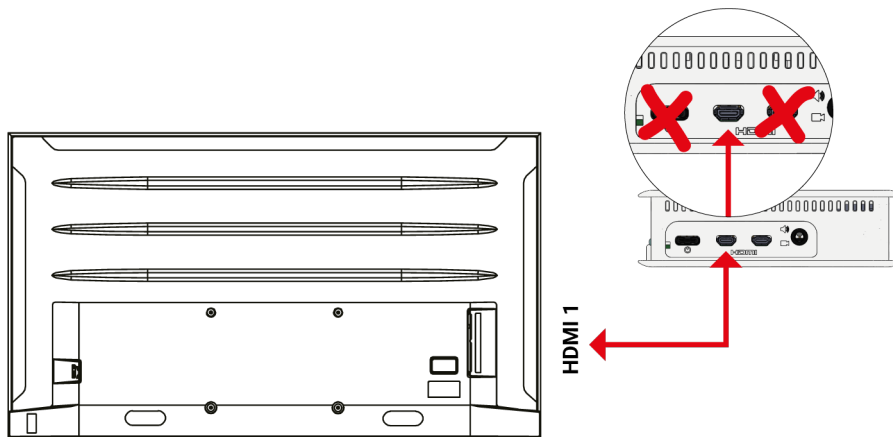

NOTICE

Make sure the mini-PC is always connected to the monitor's HDMI 1 port.

19.1 Connection of Sony monitor KJ-75X80L

Unlike the other monitor models, the Sony monitor for the Japanese market has a different connection procedure.

Follow the procedure below carefully to ensure the unit will work properly.

Proceed as follows:

1. Power the unit.
2. Carry out the first monitor setup.
3. Once the setup is complete, disconnect the power supply from the unit.
4. Connect the HDMI connector from the mini-PC to the HDMI port 1 on the monitor.
5. Reconnect the unit to the mains power supply.
6. The monitor will turn on automatically and is ready for use.

19.2 HISENSE HDMI-CEC control enabling

NOTICE

To browse the menus and change the settings, press the



buttons

To confirm, press



To enable the HDMI-CEC controls, proceed as follows:

1. Select Settings.
2. Select System.
3. Select HDMI & CEC.
Activate:
 - *CEC check.*
 - *Device Auto Power Off.*
 - *TV Auto Power On.*
- 4.

19.3 HISENSE image quality setting

NOTICE

To browse the menus and change the settings, press the



To confirm, press 

To set the image quality, proceed as follows:

1. Select **Settings**.
2. Select **Image**.
3. Select **Dynamic**.
4. Return to the MAIN menu pressing the **BACK** button.

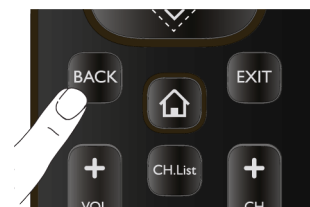

5. Turn off the monitor pressing the **ON/OFF** button.



6. Disconnect the unit's power cable for at least 5 s and reconnect it.

19.4 HISENSE Automatic Power-Off settings

NOTICE

To browse the menus and change the settings, press the



buttons

To confirm, press



To set the Automatic Power-Off for the monitor, proceed as follows:

1. Select **Settings**.
2. Select **System**.
3. Select **Timer Settings**.
4. Select **Automatic Standby**.
5. Set 3 hours of standby.

19.5 HISENSE Power On Mode settings

NOTICE

To browse the menus and change the settings, press the



buttons

To confirm, press



To set the monitor's Power On Mode proceed as follows:

1. Select **Settings**.
2. Select **Advanced Settings**.
3. Select **Power On Mode**.
4. Set **ON**.

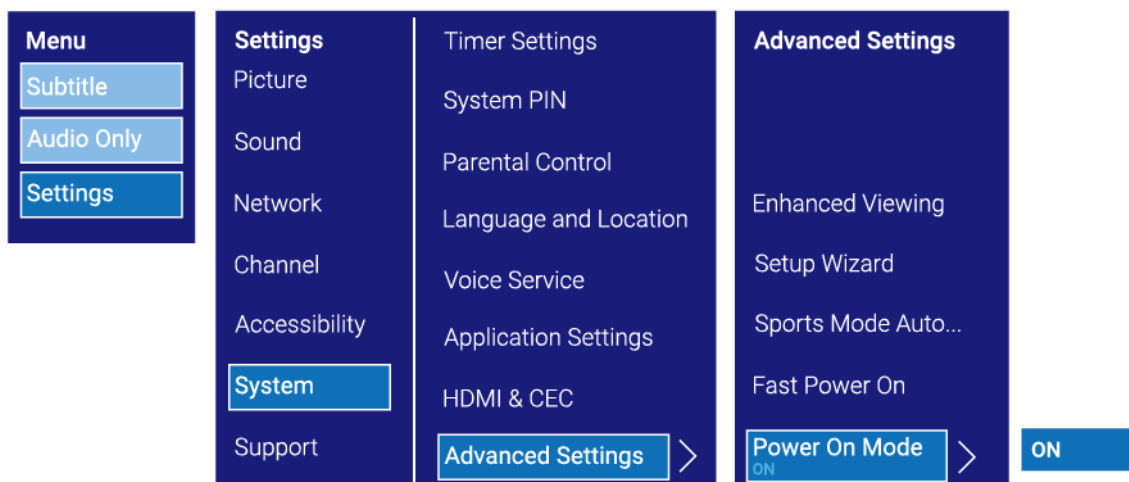

NOTICE

To browse the menus and change the settings, press the



buttons

To confirm, press



To set the monitor's Power On Mode proceed as follows:

1. Select **Settings**.
2. Select **Advanced Settings**.
3. Select **Power On Mode**.
4. Set **ON**.

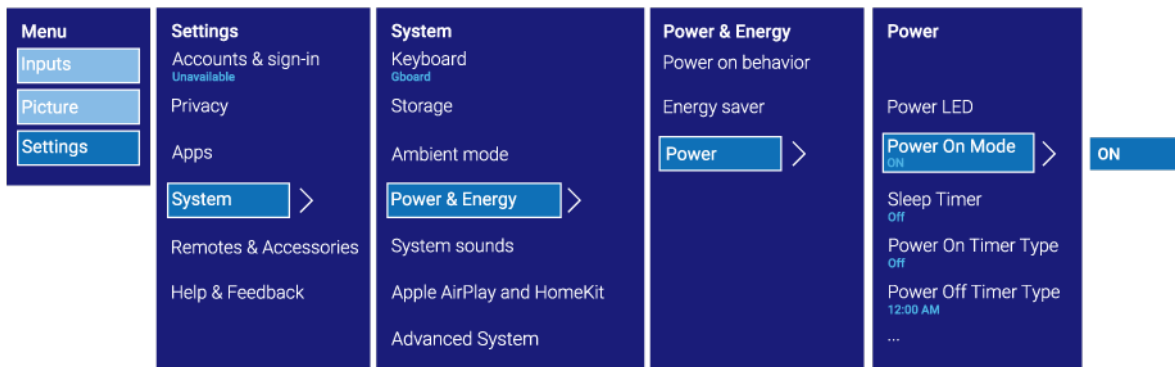

20 ADAS SYSTEM CALIBRATION

INFORMATION

Before using the equipment for the first time, you must perform the calibration procedure.

The mutual positioning of the digital level mounting bracket/calibration plate must be checked periodically and corrected by carrying out the calibration procedure if necessary.



For further information see the assembly video.

In order to carry out the calibration of the ADAS, you must have:

- a diagnostic tool;
- a display unit where the specific diagnostic software is installed;
- RCCS 3 EVO;
- any calibration panels and accessories required.

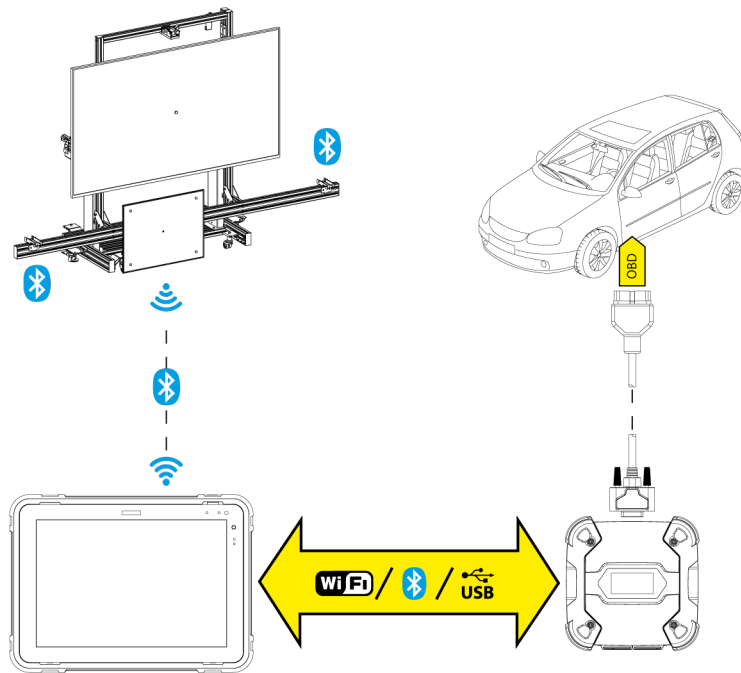

The equipment must be positioned properly to make sure the ADAS are calibrated correctly.

NOTICE

Unsuitable working surfaces may compromise the correct calibration of the system.

We recommend not working on surfaces tilted at $\geq 0.3^\circ$.

The requirements for a correct positioning of the equipment are:

- The vehicle and the equipment must be positioned on the same flat surface at 0.0° from one another or in any case within the set tolerance.
- The boot and the passenger compartment must be empty (vehicle unloaded).
- The parking brake must be engaged.
- The steering wheel must be in a central position and the wheels must be straight.

- *The fuel tank must be full.*
- *There must not be anybody inside the vehicle.*
- *If present, set the vehicle's Drive Select function to Comfort / Normal.*

Moreover, check and if necessary correct the following:

- *the tyre pressure to the value specified by the manufacturer;*
- *the engine oil level;*
- *the coolant level;*
- *the vehicle's front and the surroundings of the front radar sensor;*
- *the vehicle's wheel alignment, as specified by the manufacturer.*

WARNING

The proper operation of the ADAS is extremely important for driving safety.



An imprecise or incorrect calibration may cause the system to work improperly and expose the vehicle driver and any passengers to the risk of severe injuries.

Be very careful and precise when performing the calibration, thoroughly follow the indications in the diagnostic software's documents and procedures and in the vehicle manufacturer's documents.

Proceed as follows:

1. *Power the equipment and turn on the monitor (if applicable).*
2. *Connect the diagnostic device to the vehicle's OBD socket.*
3. *Select the vehicle you wish to work on.*
4. *Launch the specific ADAS calibration software function.*
5. *Follow the on-screen instructions.*



For further information, see the software operating manual.

At the end of the calibration, before stowing the equipment, cover the monitor with the supplied cloth.

21 HANDLING

The equipment must be moved on its own wheels only and as indicated below.



WARNING

Handling the equipment incorrectly will expose the operator to the risk of injuries.

TEXA shall not be liable for any misuse of the equipment.

Proceed as follows:

1. Disconnect the power cable from the mains.
2. Act on the workstation and lower bar adjustment knob until the reference marks indicated in the image are aligned.

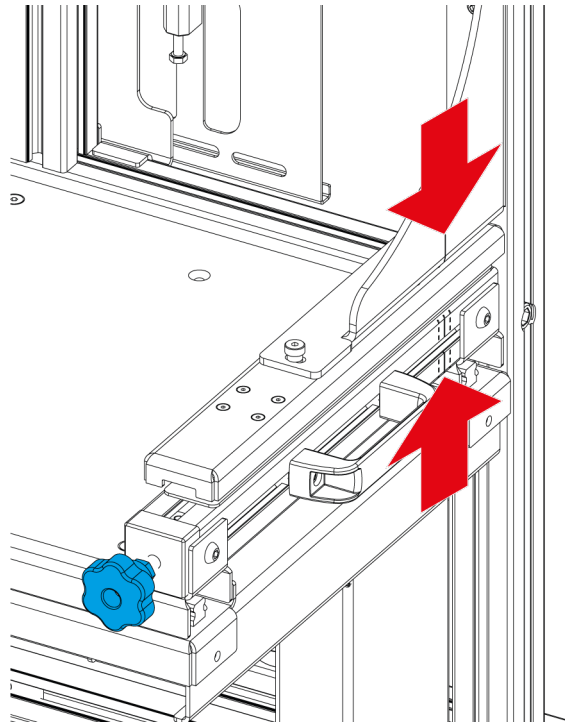

3. Make sure the unit is fully lowered, aligned with the "0" zero point, and that the horizontal movement of the workstation is locked with the knob.

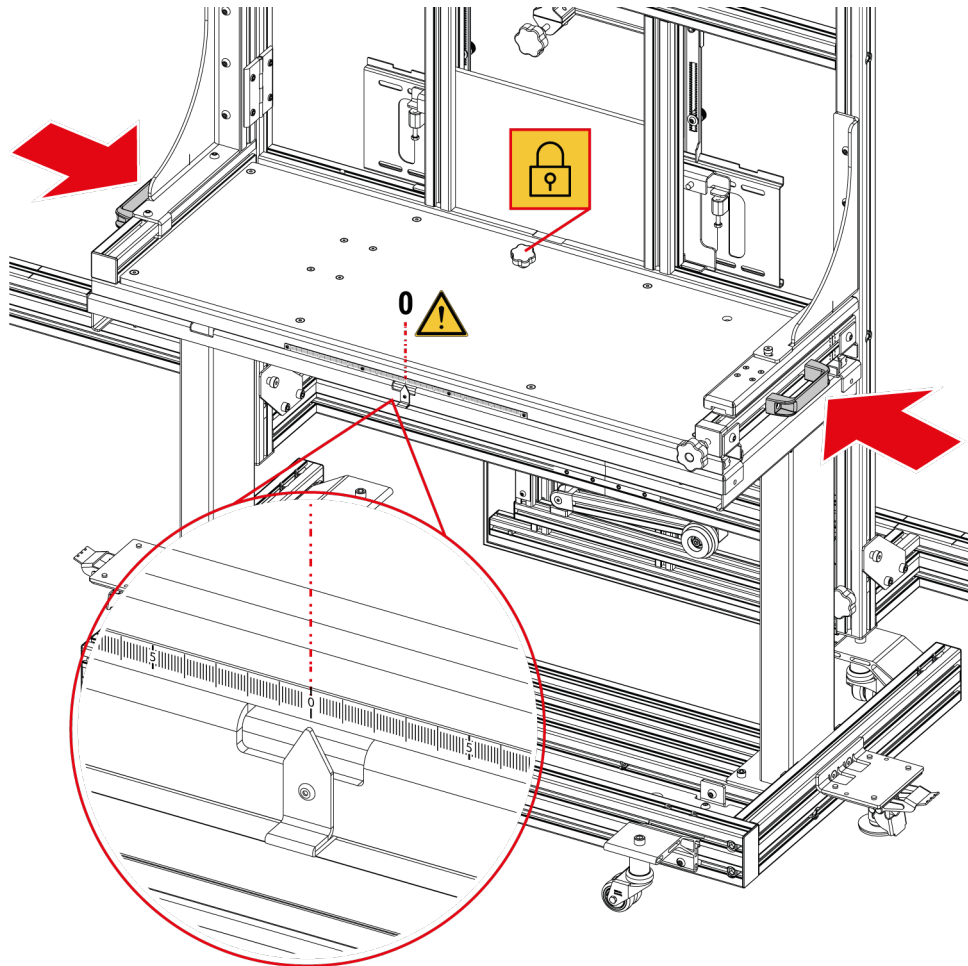

4. Lift all the levelling feet so that they do not touch the ground.

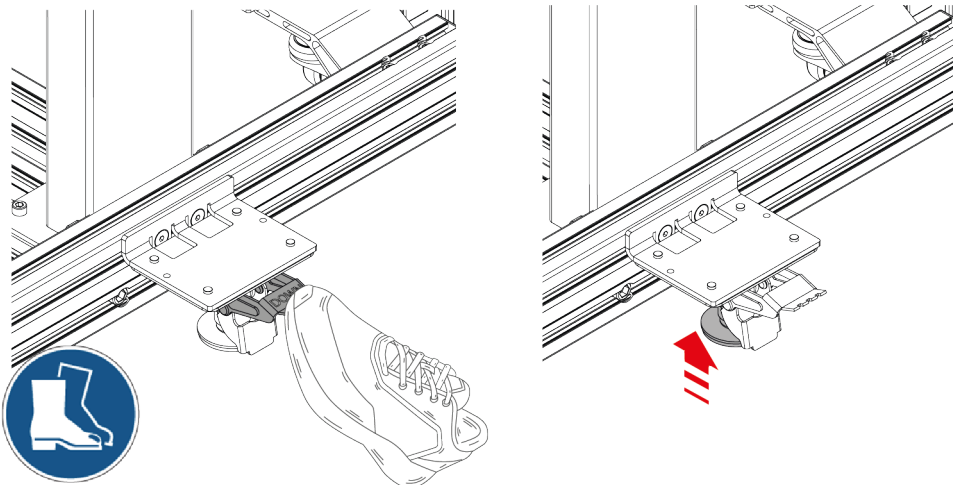

5. Clear the path by removing any obstacles (e.g. cables, pipes, etc.) that may hinder the equipment's wheels.

6. Stand behind the equipment, towards the laminate panel.

7. Push by applying force to the points indicated in the image.

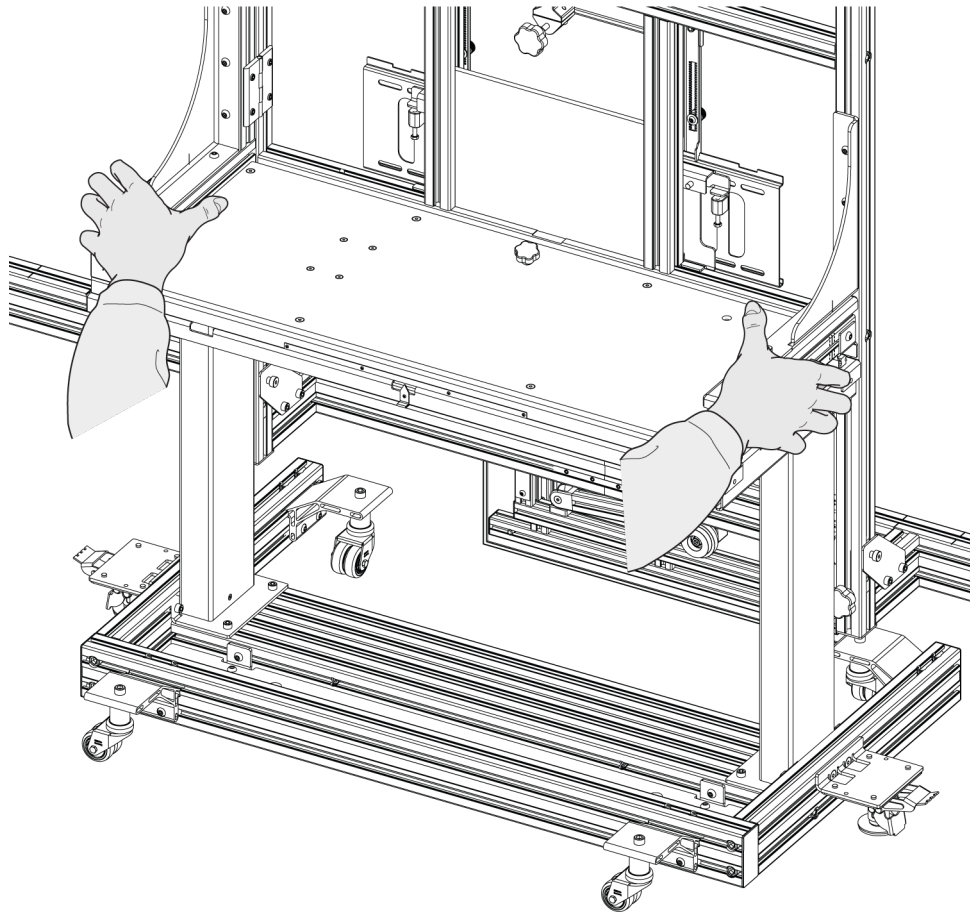

22 FIRMWARE UPDATE

The firmware in the mini-PC is updated through a specific software function and requires the connection to the display unit.

INFORMATION

During the update:

- *do not turn off the mini-PC;*
- *do not remove the micro SD card from the mini-PC;*
- *do not turn off the display unit;*
- *do not interrupt the connection between the mini-PC and the display unit.*

Proceed as follows:

1. *Power the mini-PC.*
2. *Turn on the display unit.*
3. *Start the diagnostic software.*
4. *Start the mini-PC firmware update.*
5. *Follow on screen instructions.*

Wait for the update procedure to complete.



For further information, see the software operating manual.

23 MAINTENANCE

We recommend the following:

- *carefully follow the instructions provided in this manual;*
- *keep the product clean;*
- *do not remove the lubricating oil from the tracks;*
- *do not dirty nor wet the tracks with water or other substances (except those for the maintenance);*
- *lubricate the tracks with the silicon lubricant oil every month;*
- *periodically inspect the electrical connections making sure they are in good conditions;*
- *immediately replace any damaged cables;*
- *only use original spare parts or spare parts approved by the manufacturer;*
- *contact your retailer for any extraordinary maintenance.*

INFORMATION

For further help, contact your Retailer or the Technical Assistance service.

You can see the list of authorised retailers at the following address: <https://www.texa.com/sales-network>

24 LEGAL NOTICES

TEXA S.p.A.

Via 1 Maggio, 9 - 31050 Monastier di Treviso - ITALY

Tax Code - Company Register of Treviso ID No. - VAT No.: 02413550266

Single-shareholder company subject to the direction and coordination activities of Opera Holding S.r.l.

Paid-up share capital 10.000.000 € - R.E.A. (Economic Administrative Index) No. 208102

Phone: +39 0422.791.311

E-Mail: info.it@texa.com

www.texa.com

For information regarding the legal notices, please refer to the **International Warranty Booklet** provided with the product.