

Heavy & Medium Duty/KENWORTH/Paccar/Heavy Duty//PACCR/
Delphi/PCI 2/-/-/-

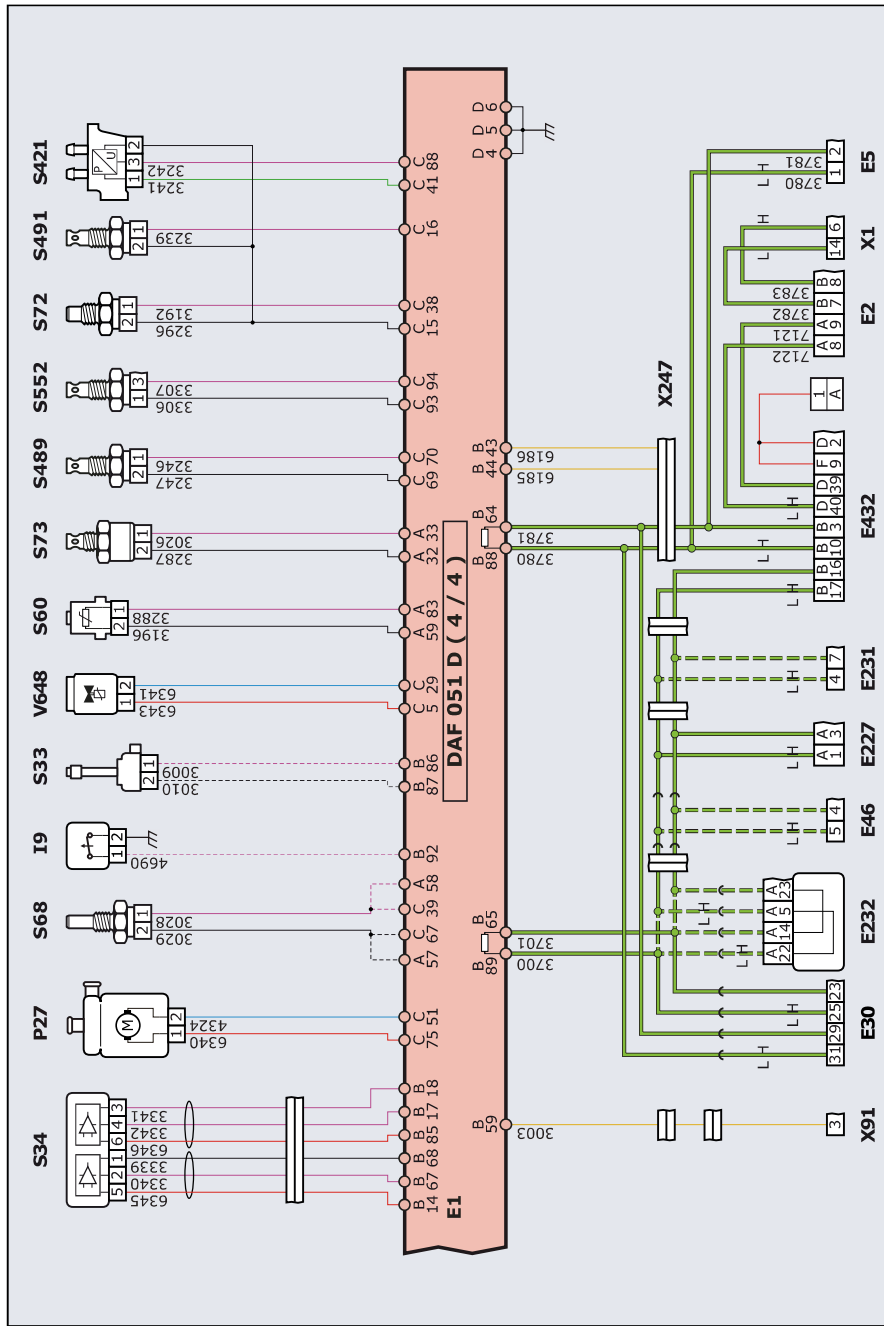

**Heavy & Medium Duty/KENWORTH/Paccar/Heavy Duty//PACCR/
Delphi/PCI 2/-/-/-**

Component list

B1	Starting battery
E037	15 A fuse
E1	Engine management control unit
E2	Gateway control unit
E227	EBS Electronic Control Unit
E231	Emergency braking electronic control unit active
E232	Hydraulic retarder ECU
E279	200 A fuse
E286	125A fuse
E30	Clutchless manual transmission ECU
E350	10 A fuse
E360	Battery cut-off module
E432	Vehicle electronic control unit
E46	Lane keep assist control unit
E488	20 A fuse
E5	Immobilizer control unit
E702	20 A fuse
E703	15 A fuse
E704	15 A fuse
E705	25 A fuse
E772	5 A fuse
E773	25 A fuse
G1	Alternator
H55	Fuel heater
I1	Ignition Switch
I9	Neutral position switch
J201	Magnetic common rail injector of cylinder n. 1
J202	Magnetic common rail injector of cylinder n. 2
J203	Magnetic common rail injector of cylinder n. 3
J204	Magnetic common rail injector of cylinder n. 4
J205	Cylinder 5 magnetic common rail injector
J206	Cylinder 6 magnetic common rail injector
M1	Starter motor
M216	Backpressure valve motor module
M217	Crankcase ventilation motor module
M218	EGR valve motor module
M35	Variable geometry turbine adjustment motor module
N4	Engine cooling fan clutch engagement magnet with digital position sensor
P20	Reducing additive pump
P27	Coolant pump
PS	The dotted connections may not be present
R15-1	Terminal 15 relay
R87	Main relay

S101	Particulate filter exhaust gas differential pressure sensor
S158	Water-in-fuel sensor
S16	Low pressure fuel sensor
S189	High pressure fuel sensor
S192	Boost pressure sensor
S20	Inductive phase sensor
S24	Inductive RPM sensor
S33	Oil level sensor
S34	Electronic accelerator pedal sensor
S363	Turbine speed sensor
S365	Particulate filter meter fuel input pressure sensor
S369	Coolant pump speed sensor
S375	Exhaust gas temperature sensor downstream of the SCR catalyst
S421	Exhaust gas recirculation differential pressure sensor
S423	Exhaust gas temperature sensor upstream of the oxidation catalyst
S47	Intake air temperature and pressure sensor
S489	Exhaust gas recirculation temperature sensor
S491	Boost air temperature downstream of the intercooler
S549	Exhaust gas pressure sensor upstream of the turbine
S55	Oil pressure sensor
S551	Exhaust gas pressure sensor downstream of the backpressure valve
S552	Exhaust gas temperature sensor downstream of the backpressure valve
S60	Fuel temperature sensor
S64	Exhaust gas temperature sensor upstream of the particulate filter
S654	Reducing additive level and quality, temperature sensor module
S656	Exhaust gas temperature sensor module
S67	Exhaust gas temperature sensor downstream of the particulate filter
S68	Coolant temperature sensor
S716	Particulate probe
S72	Oil temperature sensor
S73	Boost temperature sensor
S737	NOx sensor upstream of the SCR catalyst
S738	NOx sensor downstream of the SCR catalyst
V149	Additive tank heating solenoid valve
V361	Air shut-off solenoid valve
V371	Particulate filter fuel meter solenoid valve
V372	Particulate filter fuel cut-off solenoid valve
V544	Common rail overpressure solenoid valve
V555-1	Common rail pump unit flow control solenoid valve
V555-2	Common rail pump unit flow control solenoid valve
V597	Reducing additive dosing module
V648	Oil pump solenoid valve
V709	Compression release engine brake solenoid valve, cylinders 1 2 3
V710	Compression release engine brake solenoid valve, cylinders 4 5 6
X0	Interconnection plug
X1	Diagnostic socket
X247	Cabin-chassis interconnection

X91	Body builder connector
Z1	Terminating resistor

Heavy & Medium Duty/KENWORTH/Paccar/Heavy Duty//PACCR/
Delphi/PCI 2/-/-/-

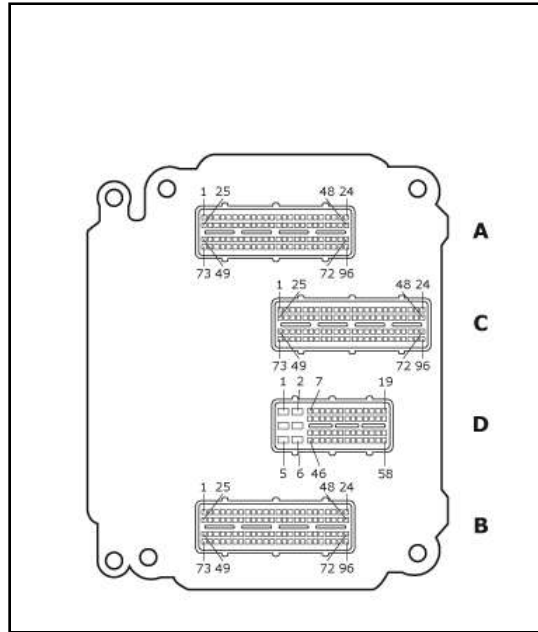

Control unit side connector pinout

- A = 96
- B = 96
- C = 96
- D = 58