

# NIGHT VISION VAG



**Download manuals**

Rev.

**TEXA**

ENGLISH.....5



# SUMMARY

<b>1 REVISION OF THE MANUAL.....</b>	<b>5</b>
<b>INTRODUCTION.....</b>	<b>6</b>
<b>2 LEGEND OF THE SYMBOLS USED.....</b>	<b>7</b>
<b>3 SAFETY RULES.....</b>	<b>8</b>
3.1 Glossary.....	8
3.2 General Rules.....	8
3.3 Operator Safety.....	9
3.4 Device Safety.....	9
<b>4 ENVIRONMENTAL INFORMATION.....</b>	<b>11</b>
<b>5 NORMATIVE INFORMATION.....</b>	<b>12</b>
<b>6 NIGHT VISION VAG.....</b>	<b>13</b>
<b>7 DESCRIPTION.....</b>	<b>14</b>
<b>8 TECHNICAL FEATURES.....</b>	<b>15</b>
<b>9 PRELIMINARY OPERATIONS .....</b>	<b>17</b>
<b>10 POWER SUPPLY.....</b>	<b>19</b>
<b>11 POWER ON/OFF.....</b>	<b>20</b>
<b>12 PERFORMING A TEST / CALIBRATION.....</b>	<b>21</b>
<b>13 MAINTENANCE.....</b>	<b>23</b>
13.1 Fuse Replacement.....	23
<b>14 LEGAL NOTICES.....</b>	<b>24</b>



## 1 REVISION OF THE MANUAL

This document is the technical manual for the product:NIGHT VISION VAG

Document Review Number:04

Date of Issue:20/10/2021

### INFORMATION



*Read this manual before using the product.*

*Attention, read the documents carefully whenever the General Risk symbol is shown.*

# INTRODUCTION

Dear Customer,

We would like to thank you for choosing a TEXA product for your workshop.

We are certain that you will get the greatest satisfaction from it and receive a great deal of help in your work.

Please read through the instructions in this manual carefully and keep it for future reference.

Reading and understanding the following manual will help you to avoid damage or personal injury caused by improper use of the product to which it refers.

TEXA S.p.A reserves the right to make any changes deemed necessary to improve the manual for any technical or marketing requirement; the company may do so at any time without prior notice.

This product is intended for use by technicians specialised in the automotive field only. Reading and understanding the information in this manual cannot replace adequate specialised training in this field.

The sole purpose of the manual is to illustrate the operation of the product sold. It is not intended to offer technical training of any kind and technicians will therefore carry out any interventions under their own responsibility and will be accountable for any damage or personal injury caused by negligence, carelessness, or inexperience, regardless of the fact that a TEXA S.p.A. tool has been used based on the information within this manual.

Any additions to this manual, useful in describing the new versions of the program and new functions associated to it, may be sent to you through our TEXA technical bulletin service.



















This manual should be considered an integral part of the product to which it refers. In the case it is resold the original buyer is therefore required to forward the manual to the new owner.





Reproduction, whole or in part, of this manual in any form whatsoever without written authorization from the producer is strictly forbidden.

The original manual was written in Italian, every other language is a translation of the original manual.

© **copyright and database rights 2021**. The material contained in this publication is protected by copyright and database rights. All rights are reserved by law and under international conventions.

## 2 LEGEND OF THE SYMBOLS USED

	Toxic material hazard		Risk of crushing hands
	Explosive material hazard		Floor level obstacle warning
	Electric shock hazard		Laser beam hazard
	Electromagnetic field hazard		Low temperature danger - freezing
	Flammable material hazard		General Risk
	Hot surface hazard		Obligation to read the instructions
	Corrosive substance hazard		Safety glasses required
	Risk of noise level above 80 dB(A)		Protective gloves required
	Moving Parts Risk		Disconnect mains plug from electrical outlet

	This is not a safety symbol. It indicates a hazardous situation which, if not avoided, will result in serious permanent injury or death.
	This is not a safety symbol. It indicates a hazardous situation which, if not avoided, may result in serious permanent injury or death.
	This is not a safety symbol. It indicates a hazardous situation which, if not avoided, may result in minor injury.
	This is not a safety symbol. It indicates a hazardous situation which, if not avoided, may result in material damage.
	This is not a safety symbol. It indicates important information.

## 3 SAFETY RULES

The technology used for the design and manufacturing control of **NIGHT VISION VAG** makes it a reliable, simple and safe device to use.

Personnel in charge of using the diagnostic tools is required to follow the general safety rules and use the **NIGHT VISION VAG** devices for their intended use only. Furthermore, they are required to carry out the maintenance as described in this manual.

All the requirements based on the following must be assessed and applied:

- *Labour inspectorate.*
- *Trade associations.*
- *Vehicle manufacturers.*
- *Anti-pollution regulations.*

### 3.1 Glossary

**Operator:** qualified person in charge of using the device.

**Device:** NIGHT VISION VAG

#### INFORMATION

*The definition of "operator" cannot be applied to minors or to people with reduced physical, sensory or mental capabilities or without any experience or knowledge required.*

### 3.2 General Rules



**The operator must carefully read and understand the information and instructions in the technical documents provided with the device. If the operator is not able to read this manual, the operating instructions and safety indications must be read and discussed in the operator's native language.**

- *The operator that works on vehicles must have basic qualifications and knowledge of mechanics, automotive engineering, vehicle repairing and of the potential dangers that may arise during self-diagnosis operations.*
- *The operator must be completely clear-headed and sober when using the device; taking drugs or alcohol before or when operating the device is strictly forbidden.*
- *The operator must follow all the instructions provided in the technical documents.*
- *The operator is required to wear adequate personal protective equipment (PPE) at all times when using the device.*
- *The operator must monitor the device during the operating phases wherever this is possible in compliance with the safety measures indicated below.*
- *The operator must periodically check the electrical connections of the device, making sure they are in good condition and immediately replacing any damaged cables.*
- *The operator must periodically check the parts that are subject to wear and replace them if necessary, using only original spare parts or spare parts approved by the manufacturer.*
- *The operator must stop using the device immediately should any failure occur, and promptly contact the technical assistance.*
- *Contact your retailer for extraordinary maintenance operations.*

- Do not remove or damage the labels and the warnings on the device; do not in any case make them illegible.
- Do not remove or tamper with any safety devices the device is equipped with.

### 3.3 Operator Safety

#### NOTICE



The device was designed and built to be stable and solid once installed correctly.

Severe impacts may compromise its stability other than its functionality.

#### Safety Measures:

- Do not hit the device.
- Use the necessary safety equipment.
- Make sure the device is always firmly anchored before each use.

#### CAUTION



The device was manufactured to be electrically safe and to work with specific supply voltage levels.

Improper use may expose the operator to the risk of electric shock, even though of low intensity.

#### Safety Measures:

- Wear adequate personal protective equipment during all the operating phases.
- Do not handle or touch the device or any accessories (e.g. cables) with wet hands.
- Do not insert any metal objects (e.g. screwdrivers) into the device, especially when it is powered and turned on.

#### WARNING



The current used during the operating phases generates Electro-Magnetic Fields (EMF) near the device.

Even though of low intensity, these fields may interfere with medical prostheses, such as pacemakers.

#### Safety Measures:

- Keep away from the device after launching the operating phases.
- If you have a medical prosthesis (e.g.: pacemaker), check with your doctor as to the appropriateness of using the device or being near it.

### 3.4 Device Safety

#### NOTICE



The device was designed to be used in specific environmental conditions.

Using the device in environments with temperatures and humidity that differ from those specified may impair its efficiency.

### Safety measures:

- *Always place the device in a dry area.*
- *Do not cover the air slits on the back of the device.*
- *Do not expose or use the device close to heat sources.*
- *Do not use corrosive chemicals, solvents or harsh detergents to clean the device.*
- *Do not use the device outdoors.*
- *Only use the device inside the workshop.*

### NOTICE



**The device was designed to be mechanically tough and suitable for use in a workshop.**

**Careless use and excessive mechanical strain may impair its efficiency.**

### Safety measures:

- *Do not drop, shake or knock the device.*
- *Do not carry out any type of intervention that may damage the device.*
- *Do not open or disassemble the device.*

### NOTICE



**The device was manufactured to be electrically safe and to work with specific supply voltage levels.**

**Failure to comply with the specifications related to the power supply may impair the device's efficiency.**

### Safety measures:

- *Do not wet the device with water or other liquids.*
- *The device's power supply must always be connected following the indications provided in this manual.*
- *Do not use an external batteries to supply the device.*
- *Do not insert any metal objects (e.g. screwdrivers) into the device, especially when it is powered and turned on.*

### ! WARNING



**The electromagnetic compatibility tests carried out on the device guarantee that it can be adapted to the technologies normally used on vehicles (e.g. engine control, ABS, airbag, etc.). Nevertheless, if malfunctions occur, contact the vehicle's dealer.**

## 4 ENVIRONMENTAL INFORMATION



Do not dispose of this product with other undifferentiated solid waste.  
For information regarding the disposal of this product please see the pamphlet supplied.

## 5 NORMATIVE INFORMATION

### EU declaration of conformity

	<p>The manufacturer, TEXA S.p.A., declares that the equipment type <b>NIGHT VISION VAG</b> is compliant with the following directives:</p> <ul style="list-style-type: none"><li>• <i>EMC 2014/30/UE</i></li><li>• <i>LVD 2014/35/UE</i></li><li>• <i>ROHS: 2011/65/UE</i></li><li>• <i>Delegated Directive:2015/863</i></li></ul> <p>The full text of the EU declaration of conformity is available by contacting TEXA S.p.A.</p>
---	--

## 6 NIGHT VISION VAG

**NIGHT VISION VAG** is a device that allows calibrating the infrared cameras used by the ADAS (Advanced Driver Assistance Systems).



Calibrating the cameras requires using:

- *a diagnostic tool connected to the vehicle;*
- *RCCS calibration unit*
- *NIGHT VISION VAG.*

The calibration procedure is completely guided by the software.



**For further information see the specific help sheets available in the diagnostic software.**

## 7 DESCRIPTION

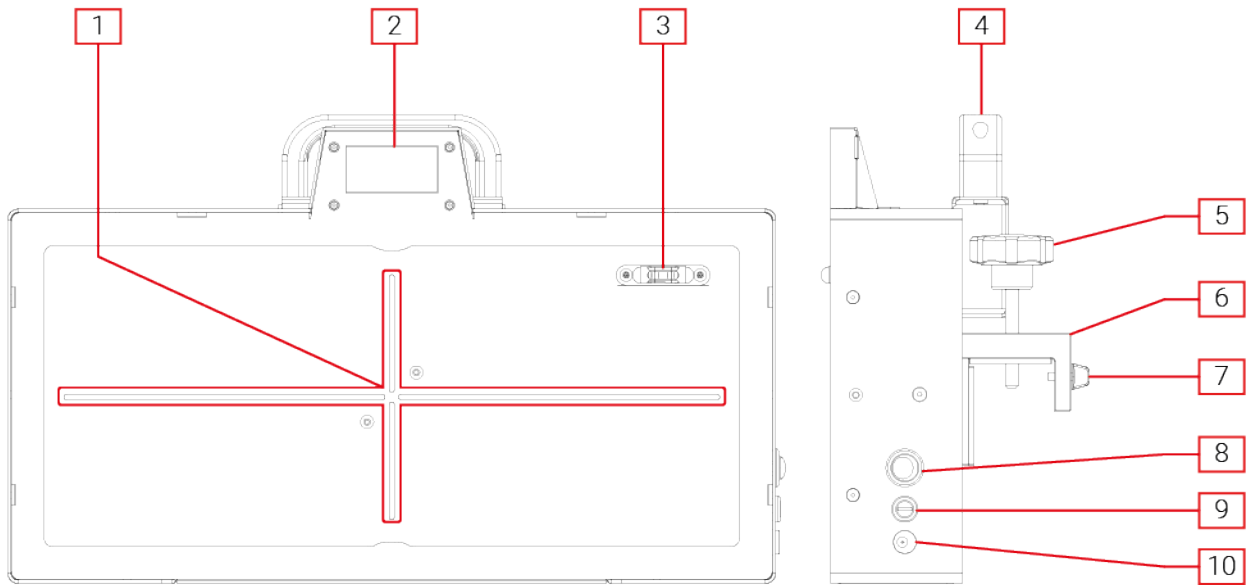

1. *Emitter*
2. *Display*
3. *Levelling bubble*
4. *Handle*
5. *Roll angle adjustment screw(x2)\**
6. *Bracket(x2)*
7. *Pitch angle adjustment screw(x2)\**
8. *ON/OFF switch*
9. *Protection fuse*
10. *Connector for external power adapter*

*(\*)Provided, not assembled. To be assembled before positioning the device.*



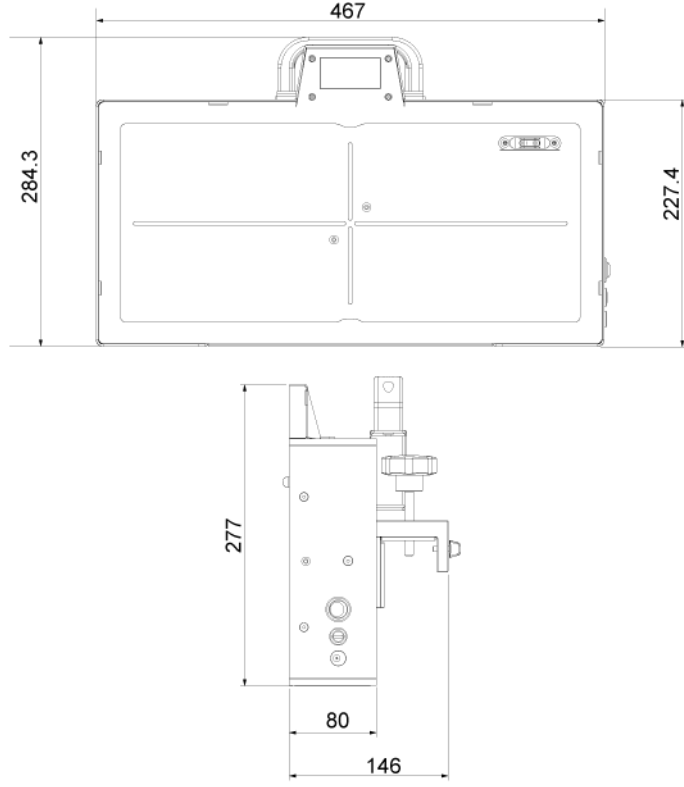

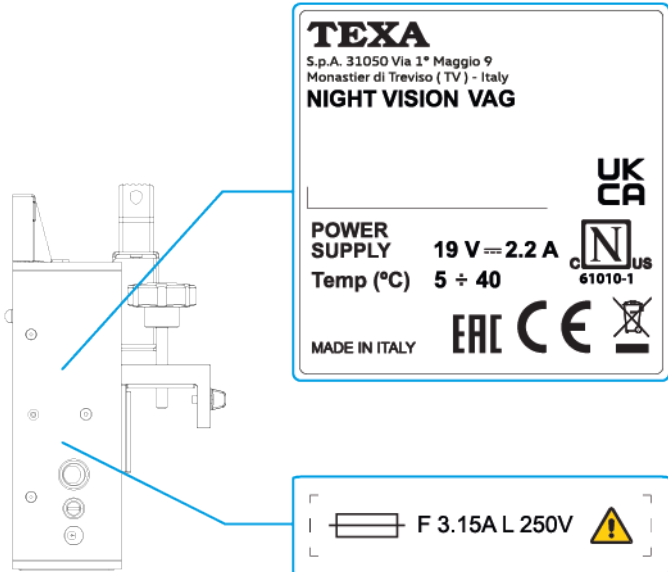
## 8 TECHNICAL FEATURES

<b>Manufacturer:</b>	TEXA S.p.A.
<b>Product name:</b>	NIGHT VISION VAG
<b>Display:</b>	Display OLED 64x128 dot
<b>Power supply:</b>	19 V <sub>===</sub>
<b>Charger:</b>	<p>External power adapter mod.:CINCON ELECTRONICS TRH070A190</p> <ul style="list-style-type: none"> <li>• <i>Input:100-240 Vac; 1.5 A; 47-63 Hz</i></li> <li>• <i>Output:19 V<sub>===</sub> 70 W</i></li> <li>• <i>Socket:IEC60320-C14</i></li> <li>• <i>Cable:H05 VV-F</i></li> <li>• <i>Cable:SJT(for American market)</i></li> </ul>
<b>Maximum consumption:</b>	2.2 A
<b>Emitters:</b>	Operating temperature (approx.):70 °C
<b>Fuse:</b>	EATON BUSSMANN SF520231 F 3.15 A L 250 V
<b>Operating temperature:</b>	5 °C ÷ 40 °C
<b>Storage temperature:</b>	- 20 °C ÷ 60 °C
<b>Storage and operation moisture:</b>	10 % ÷ 80 % HR
<b>IP protection level:</b>	IP X0 *
<b>Dimensions [mm]:</b>	 <p>The technical drawing consists of two views of the device. The top view shows a rectangular device with a width of 467 mm and a height of 227.4 mm. A carrying handle is visible at the top center. The side view shows the device's profile with a height of 277 mm, a front width of 80 mm, and a back width of 146 mm. The device has a carrying handle on top and various ports and connectors on the side.</p>
<b>Weight:</b>	4.3 kg

<b>Environmental conditions</b>	<ul style="list-style-type: none"> <li>• <i>Use:indoors</i></li> <li>• <i>Altitude (up to):2000 m</i></li> <li>• <i>Supply voltage fluctuations:± 10%</i></li> <li>• <i>Overvoltage category:II</i></li> <li>• <i>Pollution degree:2</i></li> <li>• <i>Maximum relative humidity 80% for temperatures up to 31 °C, linearly decreasing to 50% at 40 °C</i></li> </ul>
<b>Directives:</b>	ROHS 2011/65/UE Delegated directive2015/863 LVD 2014/35/UE EMC 2014/30/UE
<b>Standards:</b>	UL/IEC 61010-1:2010 EN 61326:2013
<b>Data plate:</b>	

(\*)Classification according to EN 60529:

- "X":classification of protection against solid foreign objects not required.
- "0":not protected against ingress of water.

Symbol	Meaning
	CE marking
	Waste electrical and electronic equipment
	Direct current
	Fuse
	Attention, read the documents carefully whenever the General Risk symbol is shown.

## 9 PRELIMINARY OPERATIONS

The device must be positioned on a specific support.

In the example below, the device is positioned on a RCCS calibration unit.

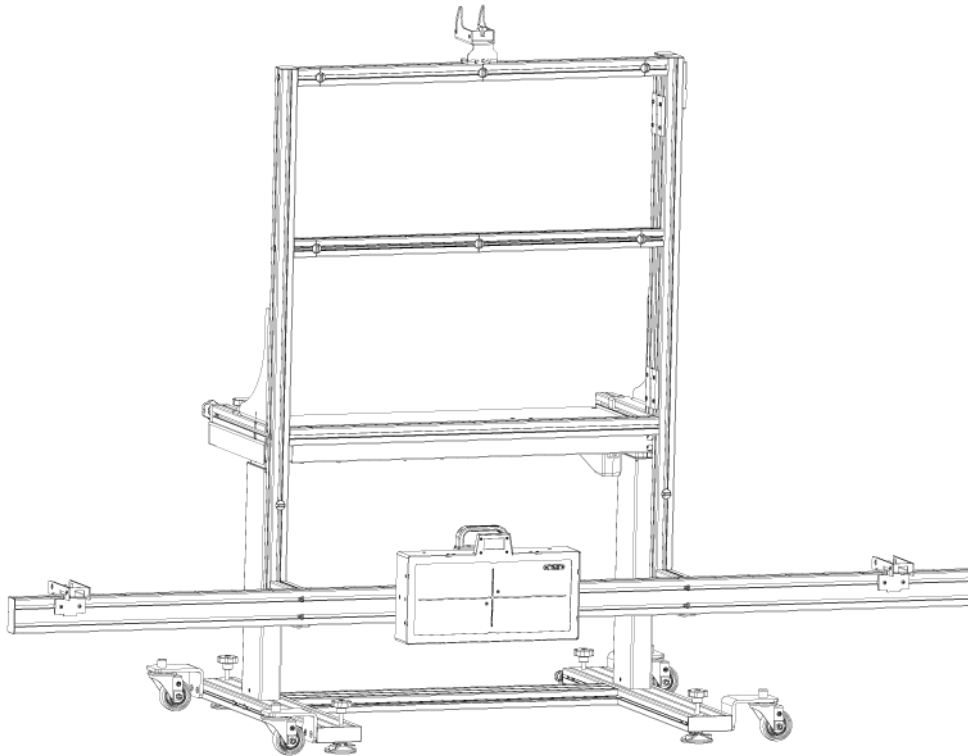

### CAUTION



The positioning procedure was designed to be simple and safe and to make the device solid and stable.

An inadequate positioning may compromise the device's stability, with consequences on its proper operation and the operator's safety.

Carefully follow the instructions below.

**Wear adequate personal protective equipment at all times while positioning the device.**

Proceed as follows:

1. Remove the radar calibration plate from the calibration unit.
2. Unpack the device carefully.
3. Grab the device by the dedicated handle to lift it.

4. Position the device on the calibration unit's bar.

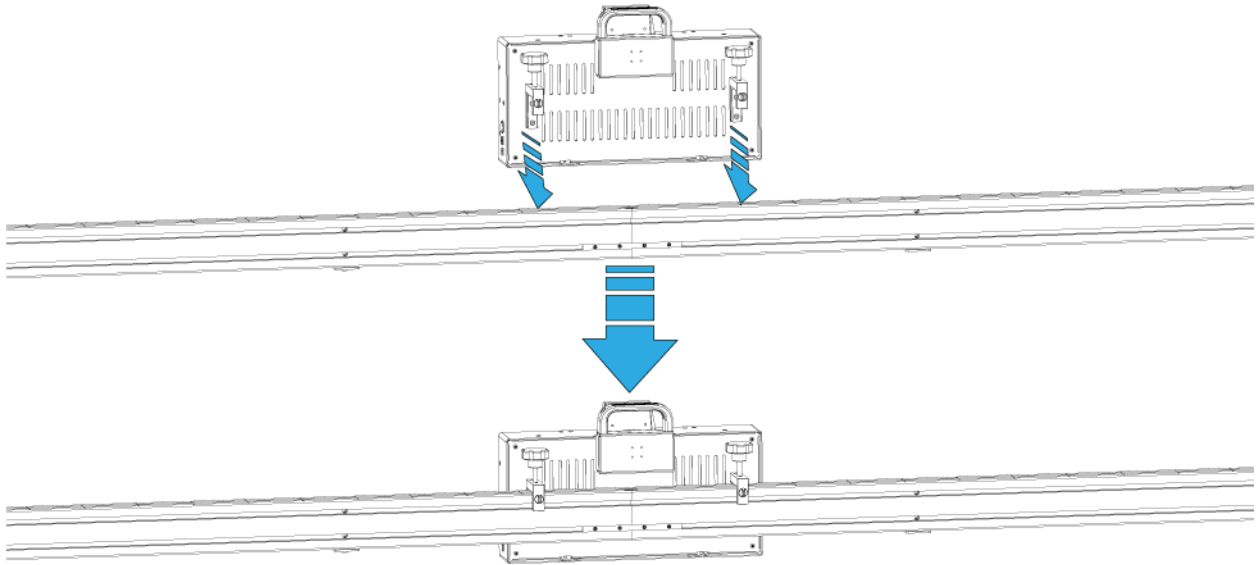

5. Level the device acting on the tilt adjustment screws.

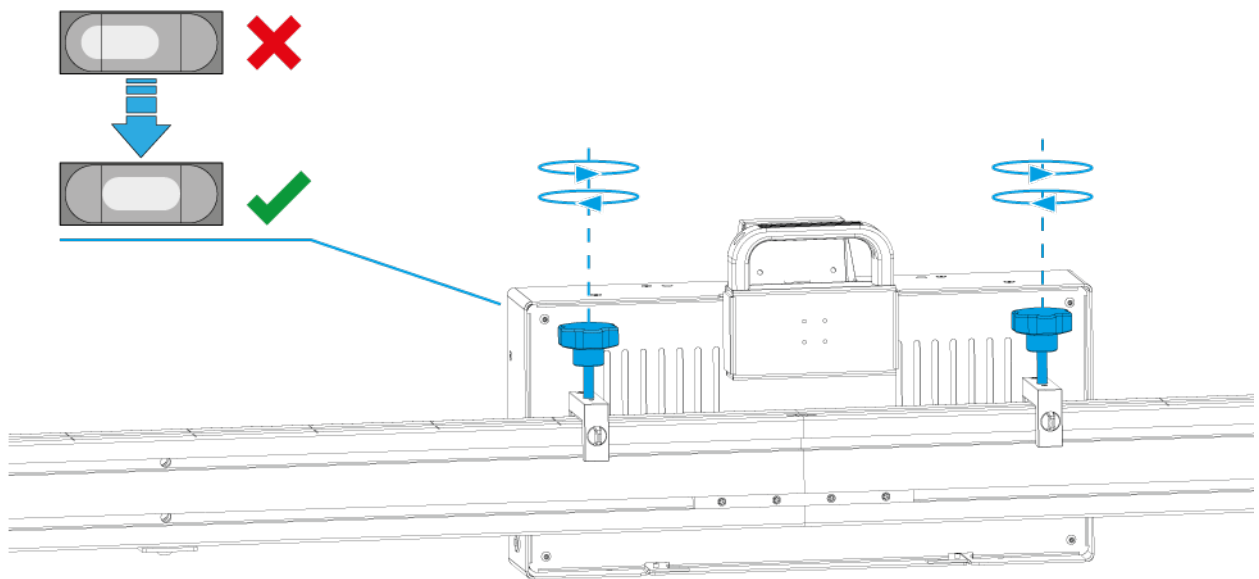

6. Tighten the fixing screws.

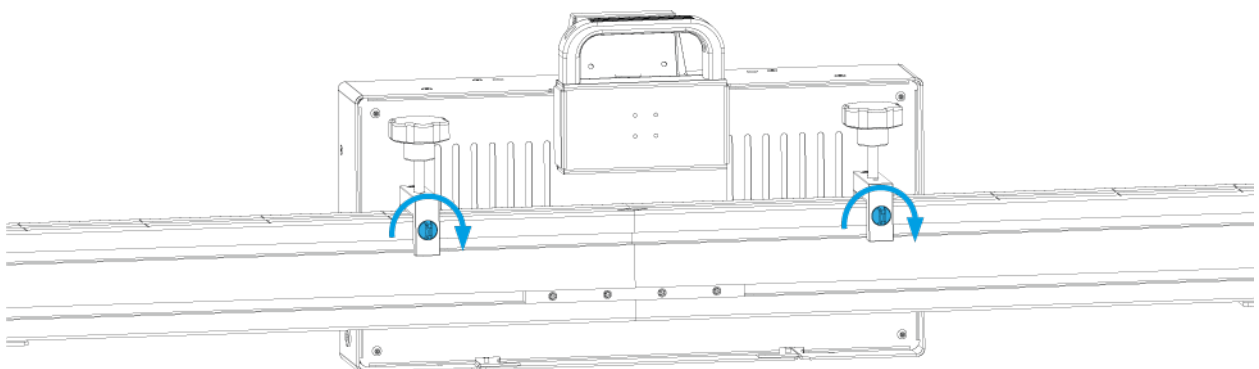

## 10 POWER SUPPLY

The device is powered by the mains through a specific external power adapter.

### **CAUTION**

The use of different chargers other than the one indicated can damage the device and expose the operator to the risk of injuries.

If the device is not used as specified by the manufacturer, the protection provided by the device may be altered.

The mains plug must be used to disconnect from the mains.

Do not position the device so that it becomes difficult to disconnect it from the mains.

Only use the power adapter:

- Model: CINCON ELECTRONICS TRH070A190
- Code: 3906885

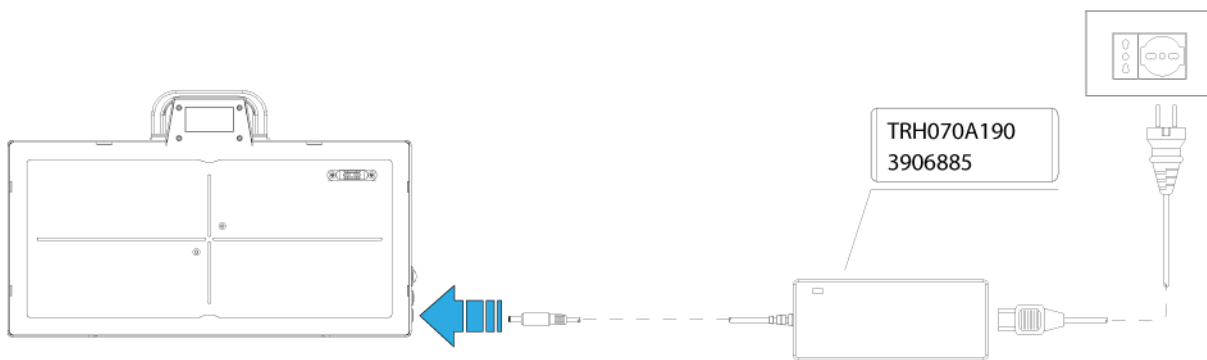

Proceed as follows:

1. Connect the external charger's jack to the connector located on the side of the device.
2. Connect the power supply cable to the external power adaptor.
3. Connect the power cable plug to a power socket equipped with a protection ground contact.

## 11 POWER ON/OFF

The switch on the side of the device is its power switch.

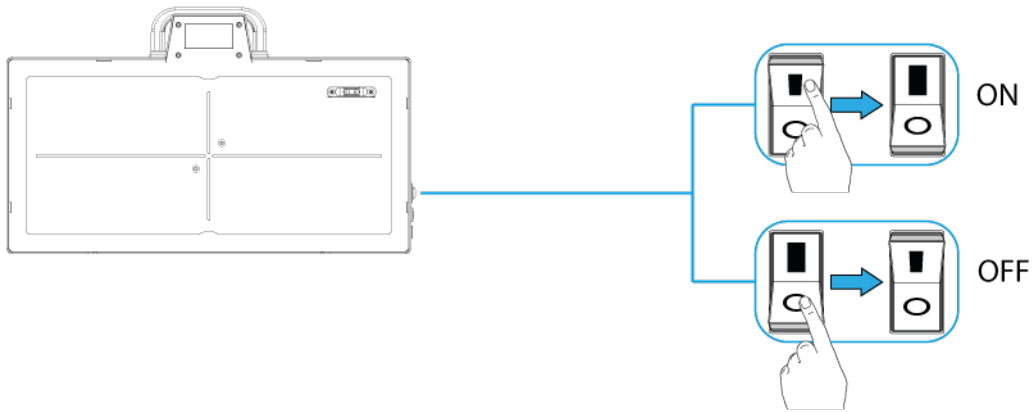

Proceed as follows:

1. *Set the switch to position ON.*

To turn off the device, proceed as follows:

1. *Set the switch to position OFF.*

### **NOTICE**



Turning off in other ways rather than the ones indicated may damage the device.

Do not turn off the device by disconnecting it from the mains.

## 12 PERFORMING A TEST / CALIBRATION

In order to perform a test/calibration, you must have the following:

- *display unit equipped with specific diagnostic software;*
- *diagnostic tool properly configured.*

Proceed as follows:

1. Position the device on the calibration unit.
2. Power the device.
3. Connect the diagnostic tool to the vehicle's diagnostic socket.
4. Start the specific software function for calibrating the sensors.
5. Turn on the device.

The device automatically starts the emitter warm-up phase and displays the temperature reached



Once the temperature required for the test/calibration has been reached, the device starts a countdown.



### INFORMATION

*Temperature required for performing the test/calibration: 70 °C*  
*Countdown duration: 20 min*

Now you can proceed with the test/calibration.

6. Follow the on-screen instructions provided by the diagnostic software.



**For further information see the diagnostic tool's Technical Manual and the software's Operating Manual.**

The device will go into standby at the end of the countdown.



## INFORMATION

*During this phase, the emitter warm-up is stopped.  
To carry out a new test/calibration or resume the one in progress, the device must be turned off and back on.*

The device shows specific error messages in case of a malfunction.



In case of a malfunction, proceed as follows:

1. *Write down the error code (e.g.: ERROR 01).*
2. *Turn off and disconnect the device.*
3. *Communicate the error code to the Technical Assistance.*

## NOTICE

**Do not try to solve the malfunction in the device on your own.**



## 13 MAINTENANCE

This product does not require special maintenance. However, we recommend the following:

- *carefully follow the instructions provided in this manual;*
- *keep the product clean using a slightly damp cloth (do not use solvents or corrosive products);*
- *periodically inspect the electrical connections making sure they are in good conditions;*
- *immediately replace any damaged cables;*
- *only use original spare parts or spare parts approved by the manufacturer;*
- *contact your retailer for extraordinary maintenance operations;*

### NOTICE



The use of spare parts and accessories that are not approved by the manufacturer may compromise the product's efficiency and safety.

Only use spare parts and accessories that are approved by the manufacturer.

Contact your retailer for any maintenance operation that is not described below.

You can see the list of authorised retailers at the following address: <https://www.texa.com/sales-network>

### 13.1 Fuse Replacement

If blown, the cartridge fuse [F] must be replaced with one with the same technical features:

- *EATON BUSSMANN SF520231 F 3.15 A L 250 V*

### WARNING



Disconnect the power adapter from the device and from the mains before carrying out any of the operations described.

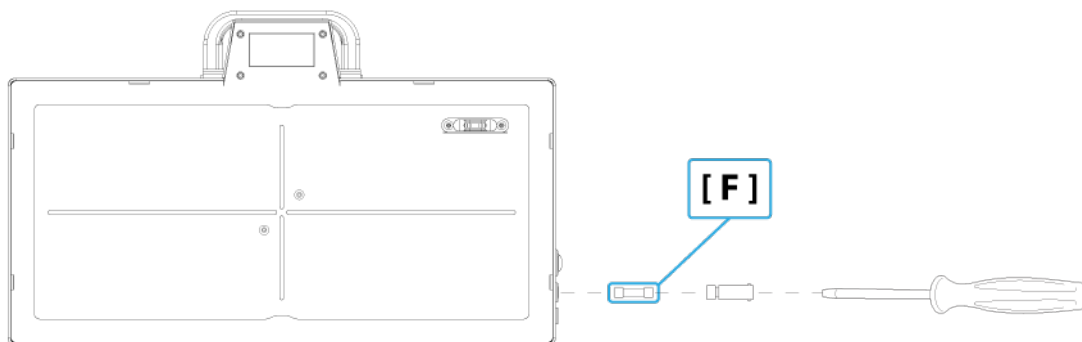

Proceed as follows:

1. *Set the switch to position OFF (O).*
2. *Pull out the fuse housing.*
3. *Remove the blown fuse.*
4. *Replace the fuse with one that has the same technical features.*
5. *Reinsert the fuse housing.*

## 14 LEGAL NOTICES

### TEXA S.p.A.

Via 1 Maggio, 9 - 31050 Monastier di Treviso - ITALY

Tax Code - Company Register of Treviso ID No. - VAT No.: 02413550266

Single-shareholder company subject to the direction and coordination activities of Opera Holding S.r.l.

Paid-up share capital 1,000,000 € - R.E.A. (Economic Administrative Index) No. 208102

Legal Representative Bruno Vianello

Phone +39 0422.791.311

Fax +39 0422.791.300

[www.texa.com](http://www.texa.com)

For information regarding the legal notices, please refer to the **International Warranty Booklet** provided with the product.