

IDC6 SOFTWARE

OPERATING MANUAL

IDC6

Rev.

TEXA

SUMMARY

1	REVISION OF THE MANUAL	11
2	INTRODUCTION	12
3	CONSULTING THE MANUAL	13
4	DESKTOP AND DIAGNOSTIC ENVIRONMENTS	14
5	UPDATES	17
6	HOME	20
6.1	Summary Bar	22
6.2	News	24
6.3	Software information	25
7	SETTINGS	26
7.1	General	28
7.1.1	Display language change	29
7.1.2	Changing the unit of measurement	30
7.2	Service Programs	31
7.2.1	Firmware update	32
7.2.2	EOBD service	33
7.2.3	Connectivity suite	34
7.2.4	Device activator	35
7.3	Environment	36
7.4	Workshop data	37
7.5	Push Notifications	38
7.6	Device Configurator	39
7.7	Authenticator	45
7.8	Updates	46
7.9	IDC5 Data Migration	47
8	VCI CONNECTION	48
9	TECHNICAL SUPPORT	51
9.1	Call Center	53
9.2	Advanced Assistance	54
9.3	Diagnostic Coverage List	55
9.4	VCI Connection Test	56
9.5	Dataprovider	57
9.6	myTEXA	58

9.7	Connection.....	59
9.7.1	Configure workshop network.....	60
9.7.2	Configure smartphone network.....	61
9.7.3	Check status of online services.....	62
10	AI GLOBAL SEARCH.....	63
11	FAVOURITES SECTION	71
12	DIAGNOSIS SECTION.....	74
13	AI SMART DIAGNOSIS.....	76
13.1	AI info.....	79
13.2	AI operations.....	80
13.3	AI spare parts.....	81
13.4	Guided Diagnosis.....	82
14	AUTO VIN SCAN 2.0.....	83
15	SCAN VIN 2.0.....	86
16	MANUAL IDENTIFICATION.....	88
17	MANUAL VEHICLE SELECTION.....	91
17.1	Side menu.....	96
18	TGS3s.....	98
19	DIAGNOSIS BY SYSTEM.....	102
19.1	Parameters.....	105
19.1.1	Favourite Parameters.....	107
19.1.2	Recording (Favourite Parameters).....	110
19.2	Errors.....	112
19.2.1	Error Clearing.....	114
19.2.2	Freeze Frame.....	115
19.3	TEXA AI.....	116
19.4	Status.....	117
19.5	ECU Information.....	118
19.6	Activations.....	119
19.7	Adjustments.....	121
19.7.1	Special Settings.....	123
19.8	Print.....	125
20	TECHNICAL DATA AND CHECKS.....	126
20.1	Tech™.....	128

20.2	Electronics™	130
20.3	Smart™	132
21	DASHBOARD	134
21.1	Parameters (Diagnosis)	134
21.2	TGS3s	135
22	TECHNICAL DOCUMENTS	138
23	ALIGNMENT CHECK	140
24	GUIDED DIAGNOSIS	142
25	REMOTE DIAGNOSIS	145
25.1	INFO CONNECT	145
25.2	INFO CONNECT 2	151
25.2.1	Configuration	151
25.2.2	Remote diagnosis	153
25.3	REMOTE DIAGNOSIS SERVICES	162
25.3.1	Remote Diagnosis	162
25.3.2	New remote diagnosis request	164
25.3.3	Start a remote diagnosis session	167
25.3.4	Remote assistance	168
25.3.5	Tickets menu	169
25.3.6	Report	170
26	DYNAMIC TESTS	171
26.1	Trip Import	175
26.2	View Trip	178
26.2.1	Zoom	180
26.3	Error Information	182
27	MILEAGE AND VIN CHECK	184
28	VEHICLE MAINTENANCE	186
29	ADJUSTMENTS AND CODINGS	188
30	ACTIVATION TESTS	190
31	EOBD PROTOCOL / OBD STANDARD PROTOCOL	192
31.1	OBD diagnosis: Evaluation of the on-board system readiness tests	196
31.2	OBD diagnosis: Evaluation of diagnostic trouble codes and MIL status	198
31.3	Mode \$01: Request for current powertrain diagnostic data	199
31.4	Mode \$02: Request for powertrain freeze frame data	201

31.5	Mode \$03: Request for powertrain emissions-related diagnostic trouble codes	203
31.6	Service \$04: Clear/reset emissions-related diagnostic information	204
31.7	Mode \$05: Request for oxygen sensor monitor test results	206
31.8	Mode \$06: Request for on-board monitoring tests carried out on specific monitored systems	208
31.9	Mode \$07: Request for emissions-related diagnostic trouble codes detected during current driving cycle or driving cycle just completed	210
31.10	Mode \$08: Request for control of an on-board system, test or component	212
31.11	Mode \$09: Request for vehicle information	214
32	HD STANDARD PROTOCOL / OHW STANDARD PROTOCOL	216
33	ISOBUS	220
34	SPECIAL CODE	222
35	MAINTENANCE SERVICE	223
36	TECHNICAL DATA / MAINTENANCE	226
36.1	Maintenance Schedule	227
36.2	Technical Data	227
37	TEXA TENSION CONTROL	228
38	SPECIAL FUNCTIONS (BIKE DIAGNOSIS)	229
39	GLOBAL SCAN	232
39.1	Quick Scan	234
39.2	DTC Detected	236
40	ECU UPDATE	238
41	SPECIAL FUNCTIONS SECTION	241
42	CAMERA / RADAR CALIBRATION	243
42.1	Device Settings	247
43	ELECTRICAL VEHICLES	248
44	BATTERY REPLACEMENT	250
45	BRAKE PAD REPLACEMENT	252
46	KEY/REMOTE CONTROL CODING	254
47	CHANGE LANGUAGE	256
48	TPMS	258
49	TRANSPORTATIONMODE PROGRAMMING	260
50	PARTICULATE FILTER/CATALYST REGENERATION	263

51 DRIVER ASSISTANCE	265
52 PARK ASSIST	267
53 MEASUREMENTS SECTION	269
54 BUS DIAGNOSIS	271
55 OSCILLOSCOPE	276
55.1 Starting/Stopping the Measurement	278
55.1.1 T/DIV	280
55.1.2 Channels	281
55.2 Autoscaling	282
55.3 Zoom	283
55.4 Cursors	284
55.5 Settings	285
56 MULTIMETER	287
56.1 Voltmeter	289
56.2 Ohmmeter	291
56.3 Ampmeter	293
56.4 Diode Test	295
56.5 Short Circuit Check	296
57 CHARGE START	297
57.1 Battery Test	299
57.2 System Charge	303
57.2.1 Charge Efficiency	304
57.2.2 Charge Cable	307
57.2.3 Ripple Output ALT+	309
57.2.4 Ripple Output D+	311
57.3 Start System	313
57.3.1 Start Test	314
57.3.2 Engine Ground Test	317
57.3.3 Starter Motor + Test	320
57.4 Result Summary	323
58 SIGNAL GENERATOR	324
58.1 PWM CURRENT DRIVE	326
58.2 PWM 5V	328
59 IGNITION	330
59.1 Spark time	333

59.2	Spark voltage.....	334
59.3	Oscilloscope.....	335
59.4	Simplified mode.....	336
59.5	Results.....	337
60	PRESSURES.....	338
60.1	Pressure Detection.....	340
60.2	Cavitation.....	342
60.3	Leak Test.....	343
60.4	Vacuum Pump.....	345
60.5	Calibration.....	348
61	TDS.....	349
61.1	Preliminary Operations.....	351
61.2	Brake disc.....	352
61.3	Fast Check.....	354
61.4	Tire.....	356
61.5	Multiple Measurements.....	358
61.6	Settings.....	359
61.6.1	Automatic configuration of the serial COM port.....	360
61.7	Workshop Data.....	361
61.8	Periodical Checks.....	362
61.9	Firmware Update.....	363
61.10	Test Archive.....	364
61.11	Print / Export report.....	365
62	HEADLIGHT ADJUST.....	366
62.1	Glossary.....	367
62.2	First start-up of eLight ONED.....	368
62.3	First start-up of eLight ONE.....	370
62.4	Software activation.....	372
62.5	HOME - HEADLIGHT ADJUST.....	377
62.5.1	Status bar.....	378
62.5.2	Home.....	379
62.5.3	Functions.....	380
62.5.4	Menu.....	381
62.6	LIGHT TEST.....	382
62.7	DIAG TEST.....	386

62.8	Photometric Analysis.....	391
62.8.1	Storage of the tests performed.....	395
62.9	TEST REPORT.....	396
62.9.1	Test report reading.....	397
62.9.2	Test report export / print.....	399
62.10	MENU.....	402
62.10.1	Settings.....	403
62.10.2	Updates.....	416
63	UTILITIES SECTIONS.....	417
64	WIRING DIAGRAMS.....	419
65	TECHNICAL DATA SHEETS.....	424
65.1	System Sheets.....	427
65.2	Vehicle Sheets.....	428
66	MEASUREMENT UNIT CONVERTER.....	429
67	AIRBAG VAG CODING.....	431
68	CUSTOMER DATA MANAGEMENT.....	433
68.1	Enter Customer.....	435
68.2	Repair.....	437
68.2.1	View Operation Data.....	440
68.2.2	Enter Action.....	441
68.2.3	Enter Operation.....	442
68.3	Vehicle Data.....	443
68.4	Client's Data.....	444
69	REPORT REPOSITORY.....	445
70	EXCHANGE MANAGER.....	446
71	BIKE / MARINE / TRUCK / OHM CABLES.....	448
71.1	Cable List	449
71.2	Cables Available by Brand.....	450
71.3	Cable Cases.....	451
71.4	Adapters.....	452
72	SUPPORT SECTION.....	453
73	PASSTHRU.....	454
73.1	Passthru Manufacturers' Link.....	456
73.2	Passthru Assistance.....	457

74	PARTNERS' LINKS	459
75	myTEXA	460
75.1	Diagnostic Reports	462
75.1.1	Dashboard configuration through filters	462
75.1.2	Periodic report scheduling	463
75.1.3	General report of diagnoses	464
75.1.4	Diagnosis by system	466
75.1.5	Operator Activity	468
76	CALL CENTER ASSISTANCE	470
77	ACTIVATION CENTRE	471
77.1	Installation of an ACTIVATION or a SERVICE	472
78	iSUPPORT	474
78.1	Technical Support	475
78.2	Diagnosis Development Requests	477
78.3	Self-diagnosis SW fault notification	479
79	HELP / SUPPORT	480
79.1	User Manual	481
79.2	Online Basic Instructions	482
79.3	License agreement	483
79.4	Release Notes	484
79.5	Diagnostic Coverage List	485
79.5.1	Diagnostic coverage list	486
79.5.2	New feature list of the latest version	488

1 REVISION OF THE MANUAL

This document is the operating manual for the product: IDC6

Document Review Number: 05

Date of Issue: 28/02/2025

INFORMATION	<i>Read this manual before using the product. Read the documents carefully whenever the General Risk symbol is shown.</i>
	

2 INTRODUCTION

Dear Customer,

We would like to thank you for choosing a TEXA product for your workshop.

We are certain that you will get the greatest satisfaction from it and receive a great deal of help in your work.

Please read through the instructions in this manual carefully and keep it for future reference.

Reading and understanding the following manual will help you to avoid damage or personal injury caused by improper use of the product to which it refers.

TEXA S.p.A reserves the right to make any changes deemed necessary to improve the manual for any technical or marketing requirement; the company may do so at any time without prior notice.

This product is intended for use by technicians specialised in the automotive field only. Reading and understanding the information in this manual cannot replace adequate specialised training in this field.

The sole purpose of the manual is to illustrate the operation of the product sold. It is not intended to offer technical training of any kind and technicians will therefore carry out any interventions under their own responsibility and will be accountable for any damage or personal injury caused by negligence, carelessness, or inexperience, regardless of the fact that a TEXA S.p.A. tool has been used based on the information within this manual.

Any additions to this manual, useful in describing the new versions of the program and new functions associated to it, may be sent to you through our TEXA technical bulletin service.

This manual should be considered an integral part of the product to which it refers. In the case it is resold the original buyer is therefore required to forward the manual to the new owner.

Reproduction, whole or in part, of this manual in any form whatsoever without written authorization from the producer is strictly forbidden.

The original manual was written in Italian, every other language is a translation of the original manual.

© **copyright and database rights2025** The material contained in this publication is protected by copyright and database rights. All rights are reserved by law and under international conventions.

3 CONSULTING THE MANUAL

The environments of this software, even though they have been designed for significantly different vehicle categories, are all structured and operate the same way.

This allows the operator to easily switch from one of the installed work environments to another, using the same logic for selecting the vehicle, launching the functions, etc.

INFORMATION



The availability of some functions or services may depend on factors such as, for example:

- *operating environment*
- *type of activation*
- *type of license*
- *geographic area*

For further information, contact your retailer.

The availability of a function or service for a specific environment is graphically represented by the related icon located at the beginning of the chapter.

Example:

1 SELF-DIAGNOSIS 	The icons indicate that the function is supported by all the environments.
1.1 Self-diagnosis Disclaimer	This subchapter still refers to a function that is supported by all the environments.
1.2 Connecting to the Vehicle's Control Unit	This subchapter still refers to a function that is supported by all the environments.
...	
1.7 Special Code WEB 	The section of the chapter describes a function supported by the TRUCK environment only.

The AGRI and CONSTRUCTION environments are part of the OFF-HIGHWAY category.

The user can decide whether to purchase the entire category or only the desired environment.

Refer to the AGRI environment icon in the manual for the functions that are available for the CONSTRUCTION environment.

4 DESKTOP AND DIAGNOSTIC ENVIRONMENTS





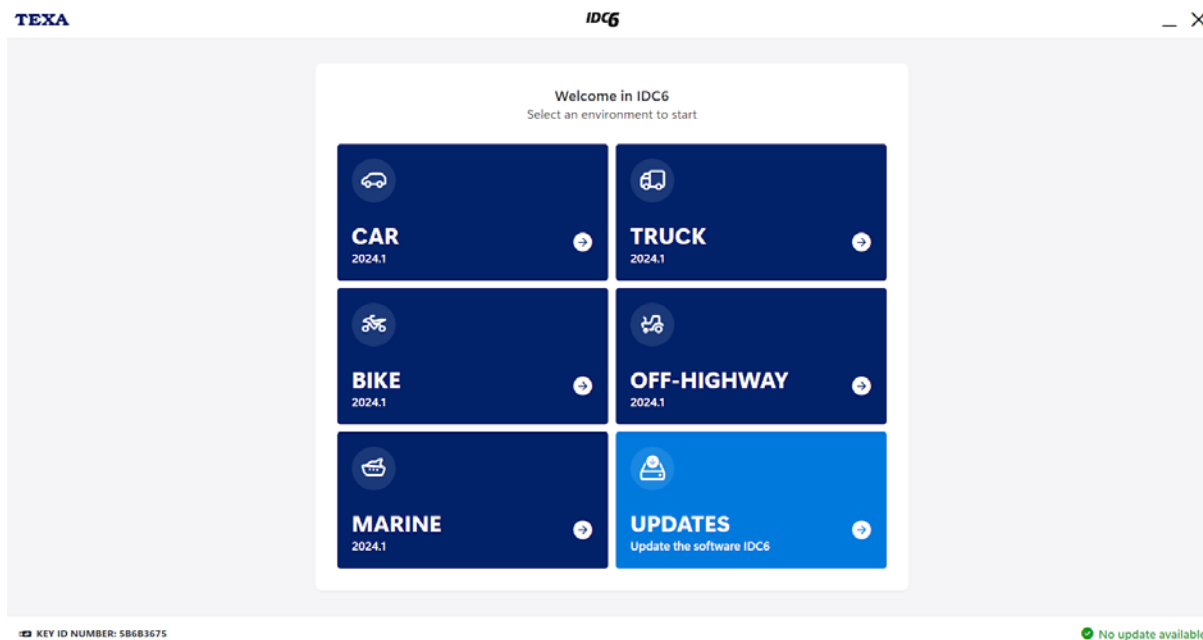

IDC6 is a multi-environment software that allows carrying out all the diagnostic operations connected to the self-diagnosis, on-board diagnosis, electrical measurements and emissions analysis easily and professionally.

The screen below shows the IDC6 **DESKTOP**, that is the software's start screen.



The icons in this screen allow selecting any one of the IDC6 environments.

The environments are:

Icon	Name	Description
	CAR	Cars and light commercial vehicles. If purchased, even the SUPERCAR category is available.
	TRUCK	Heavy and light commercial vehicles, trailers and semi-trailers, buses and industrial engines.
	BIKE	Motorcycles, scooters, quads and water scooters.
	OFF-HIGHWAY	The software is divided in: <ul style="list-style-type: none"> • OHW AGRI: <i>agricultural machinery like tractors, lifters, unifeed mixers, combine harvesters;</i> • OHW CONSTRUCTION: <i>construction machinery and earth-moving equipment, like excavators, loaders, backhoe loaders, dumpers and bulldozers.</i>
	MARINE	Inboard and outboard engines and water scooters

INFORMATION

In order for an environment to start correctly it needs to be active; this means that it has been purchased and unlocked with the specific countercode.

The UPDATES function is also available.

The function can be launched by clicking on the specific icon.

Icon	Name	Description
	UPDATES	It allows checking for updates, patches and new languages available for the activated environments and to download them.

Other information that can be found in this screen is:

KEY ID NUMBER	<p>The code in the lower left corner of the screen univocally identifies the HASP key connected to the display unit in which the software is installed.</p> <p>The code must be provided to the Technical Assistance or Distributor any time it is requested.</p> <p>The software cannot be launched if the HASP key is not connected to the display unit.</p>
UPDATE AVAILABILITY	<p>The software checks the availability of updates as soon as it is launched.</p> <p>The search and its result are notified in the lower right corner of the screen.</p> <p>The display unit must be connected to the Internet.</p>

Proceed as follows:

1. Click on the icon of the desired environment.

If at least one function has been selected as a favourite, the software displays the **FAVOURITES** section as the environment's **HOME** screen.

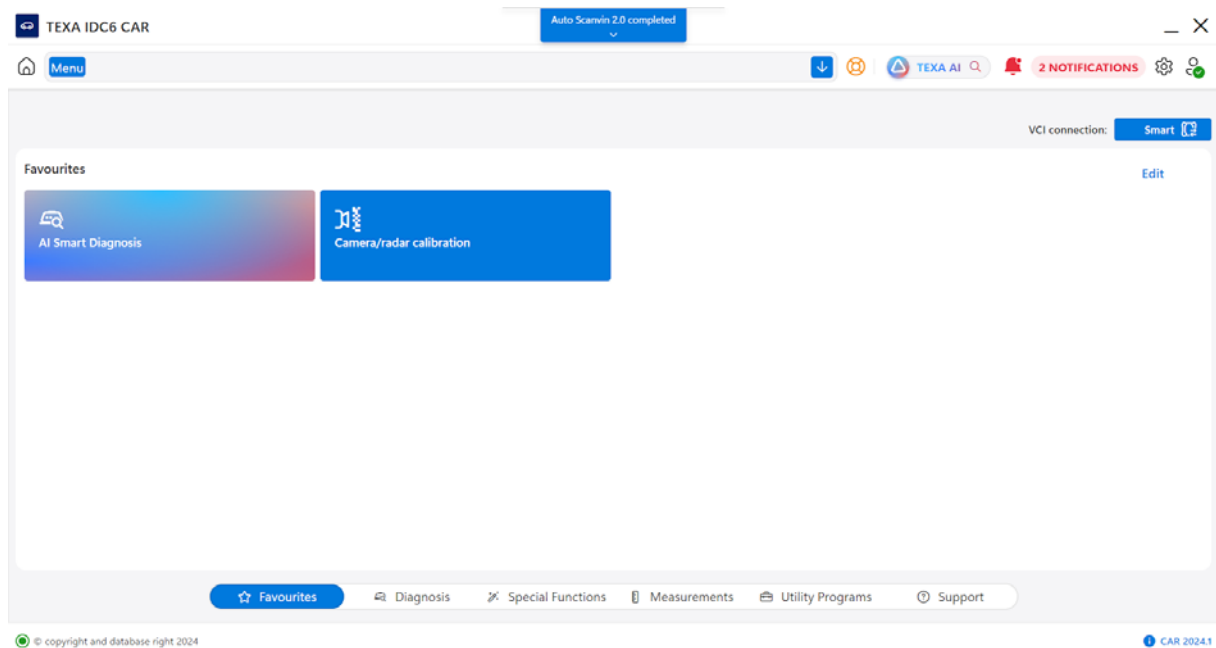

If no function has been selected as a favourite, the software displays the **DIAGNOSIS** section as the environment's **HOME** screen.

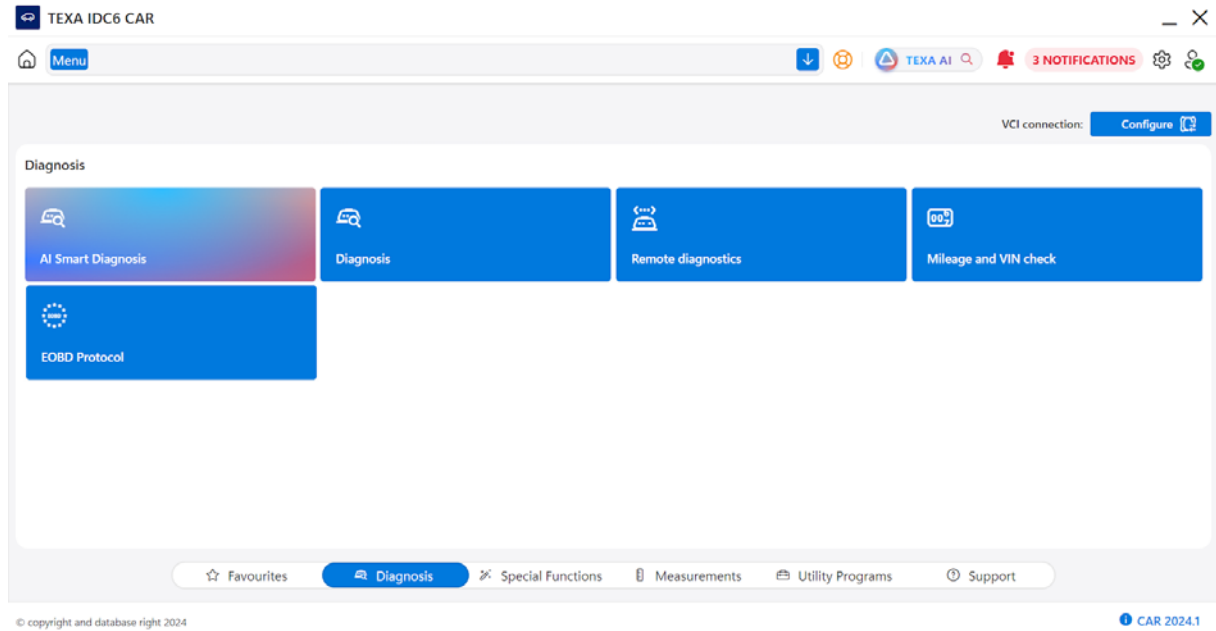

INFORMATION

Different favourite functions can be selected for each owned environment.

The functions in the FAVOURITES section refer to the environment being used.

5 UPDATES

This function allows you to check for updates, patches and new languages available for the activated environments and to download them.

NOTICE

Keep the display unit powered by the mains at all times while updating.

Make sure the Internet connection remains active as long as necessary for the download to complete.

INFORMATION

The download and installation of the updates will take place based on what is set in the Updates section  in the Settings function



INFORMATION

We always recommend you log in to the myTEXA portal through



Proceed as follows:

1. Press: 

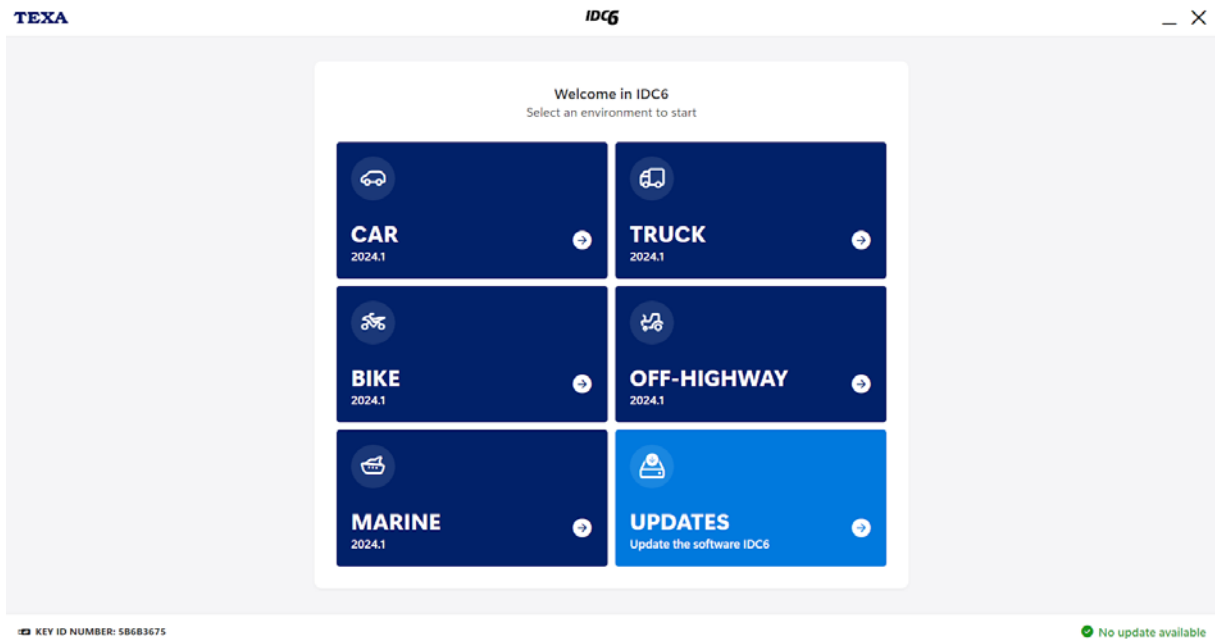

INFORMATION

Only the available updates relating to the purchased environments are displayed.

2. Press: 



3. Press: 

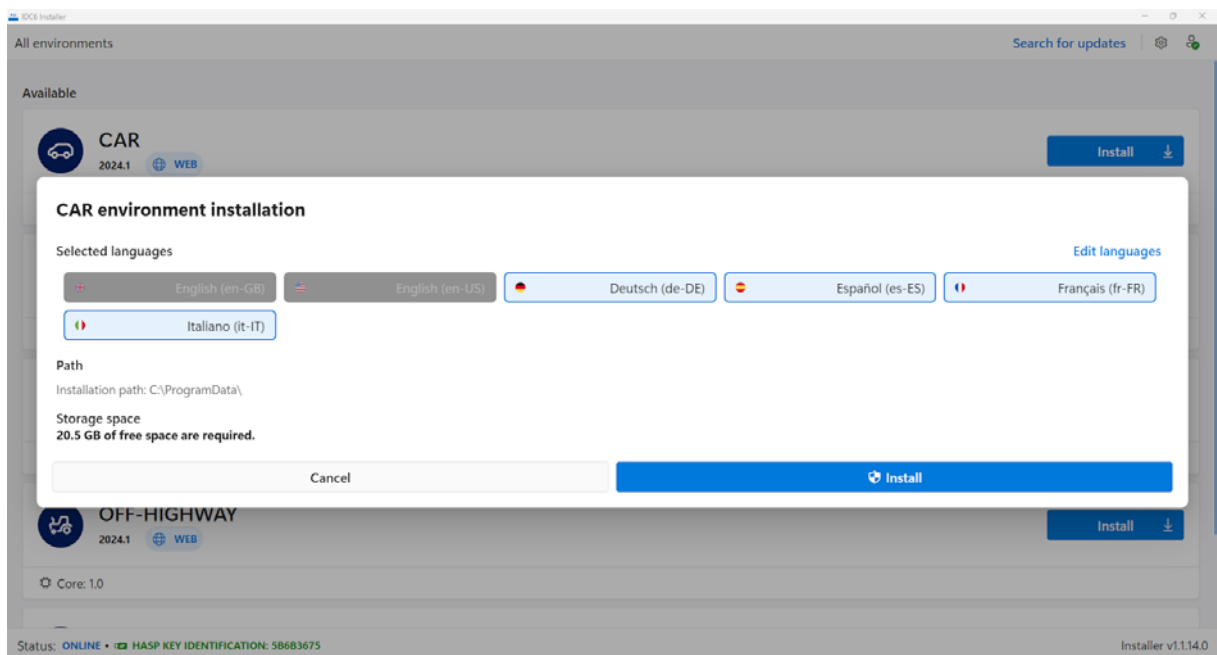

INFORMATION

The software is installed in English by default.

*Further languages to be installed can be selected by pressing: **Edit languages***

The installed languages must be purchased and activated before they can be used.

Wait for the update download and installation to finish.

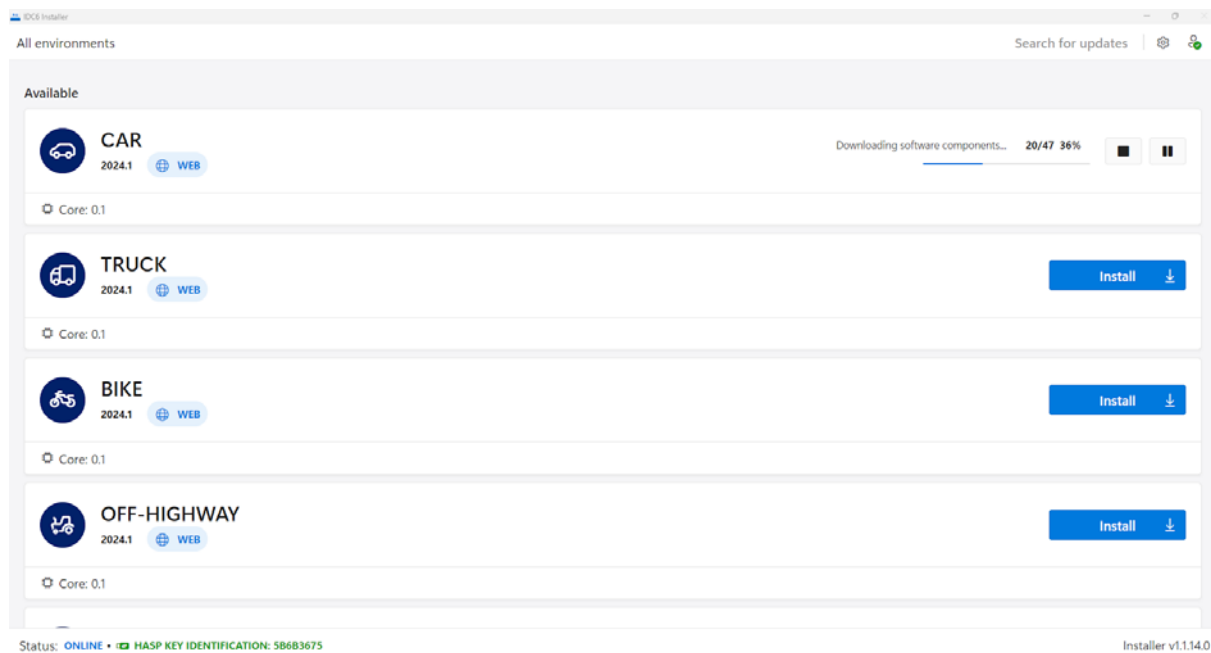

4. Press:Start IDC6

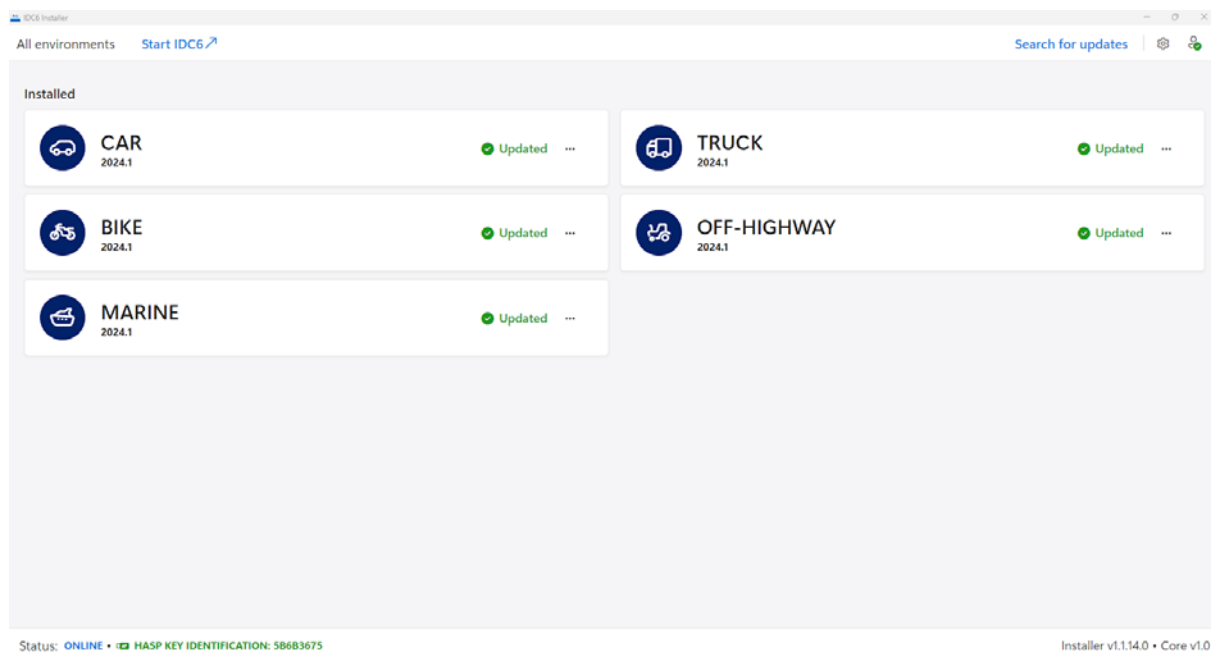

INFORMATION

The search for updates can be forced by pressing:Search for Updates

6 HOME



Click on the icon of the desired environment to access the related **HOME** screen.

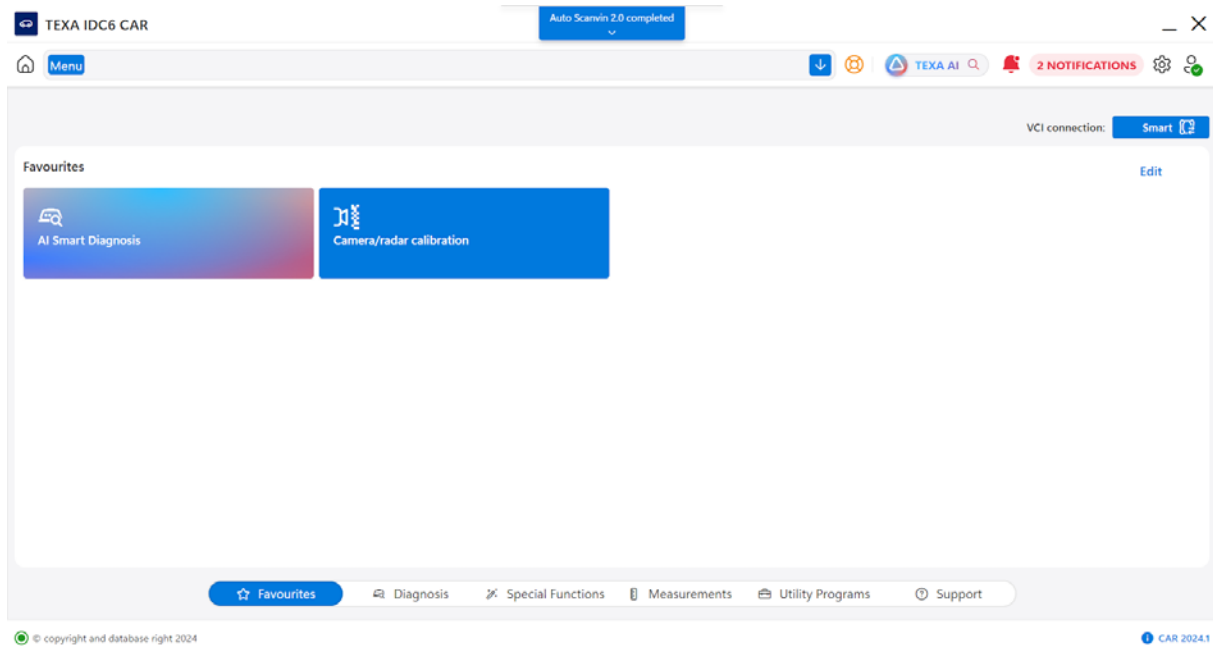







In the upper part of the screen there is:

Icon	Name	Description
	HOME	It allows returning to the HOME screen.
---	Summary bar	It shows the selection made, divided into selection levels.
	Technical support	It allows accessing the menu of the technical support functions, among which the transmission of an assistance request.
	TEXA AI	It allows launching the search function powered by AI.
	News	It allows accessing the section with the latest news on products, services and software update availability.
	Settings	It allows accessing the functions that are common to all the environments, such as language change and search for updates.
	Authenticated diagnosis	It allows connecting to your myTEXA account.
---	VCI connection	It shows the current connection mode with the VCI.
	Device configurator	It allows accessing the Device configurator function. If a VCI is already configured, it allows selecting the connection mode: <ul style="list-style-type: none"> • <i>Smart</i> • <i>Manual</i>

In the centre part of the screen there are the icons related to the current section.

In the lower part of the screen there are the icons of the sections in which the software functions were divided into:

Icon	Name	Description
	Favourites	It gathers the functions selected by the operator for a customised HOME screen.
	Diagnosis	It gathers the diagnostic functions. Ex.:Diagnosis, Remote diagnosis, etc.
	Special functions	It gathers the special functions. Ex.:Electric vehicles, Battery replacement, etc.
	Measurements	It gathers the measuring functions. Ex.:Emissions analysis, Oscilloscope, etc.
	Utilities	It gathers the utility accessory functions. Ex.:Customer management, Report repository, etc.
	Support	It gathers the support functions for the diagnosis and software use. Ex.:Solved Problems, Documentation, etc.

In the lower right corner there is the version number of the environment currently being used.

Click on the software version number to access the **INFORMATION** screen.

6.1 Summary Bar

The summary bar indicates the selection made, divided into the levels of selection.

By clicking on one of the segments that make up the bar, you can return to the corresponding level of selection.

The software also provides the following lists:

- *Last 20 Selections;*
- *Selections saved.*

INFORMATION

The contents of the summary bar and lists are specific for each environment.

Proceed as follows:

1. Press: 

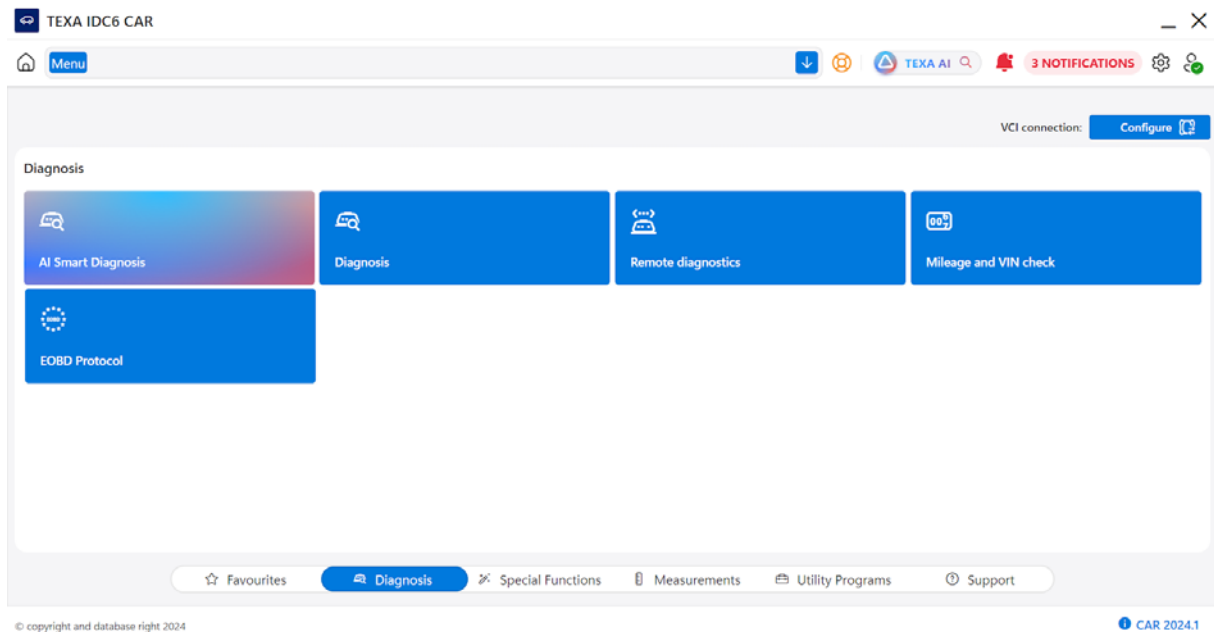

2. Click on the desired selection.

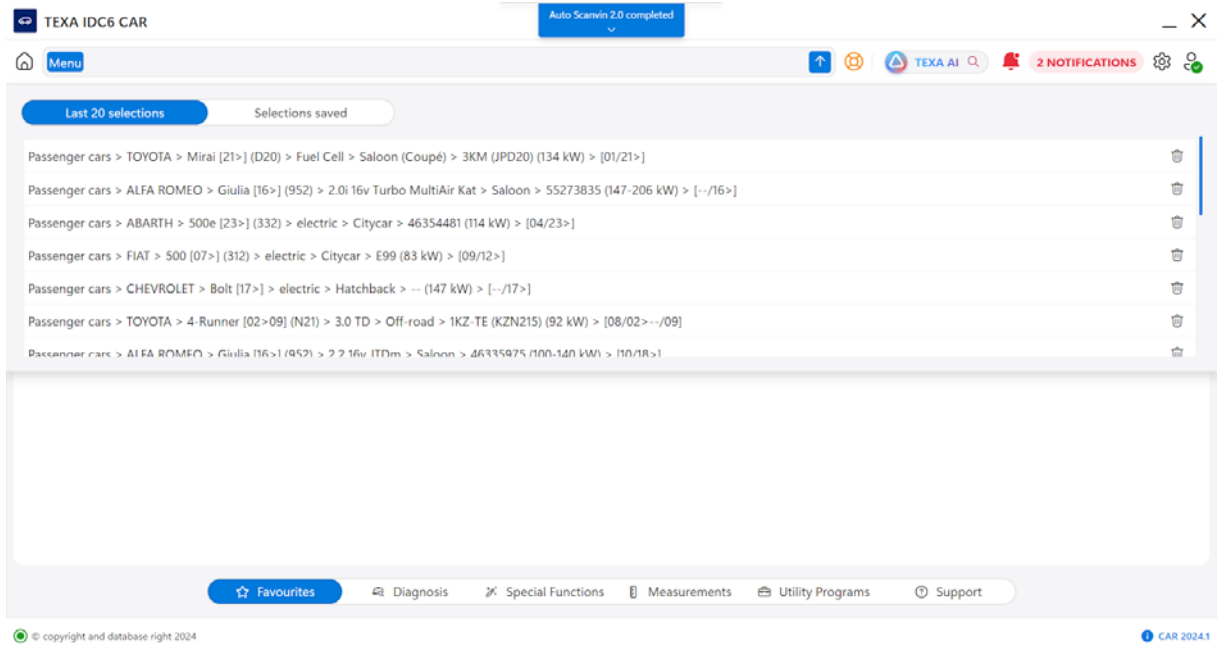

INFORMATION

To delete the selections in the lists, click on: 

3. The software positions itself automatically in the self-diagnosis functions screen.

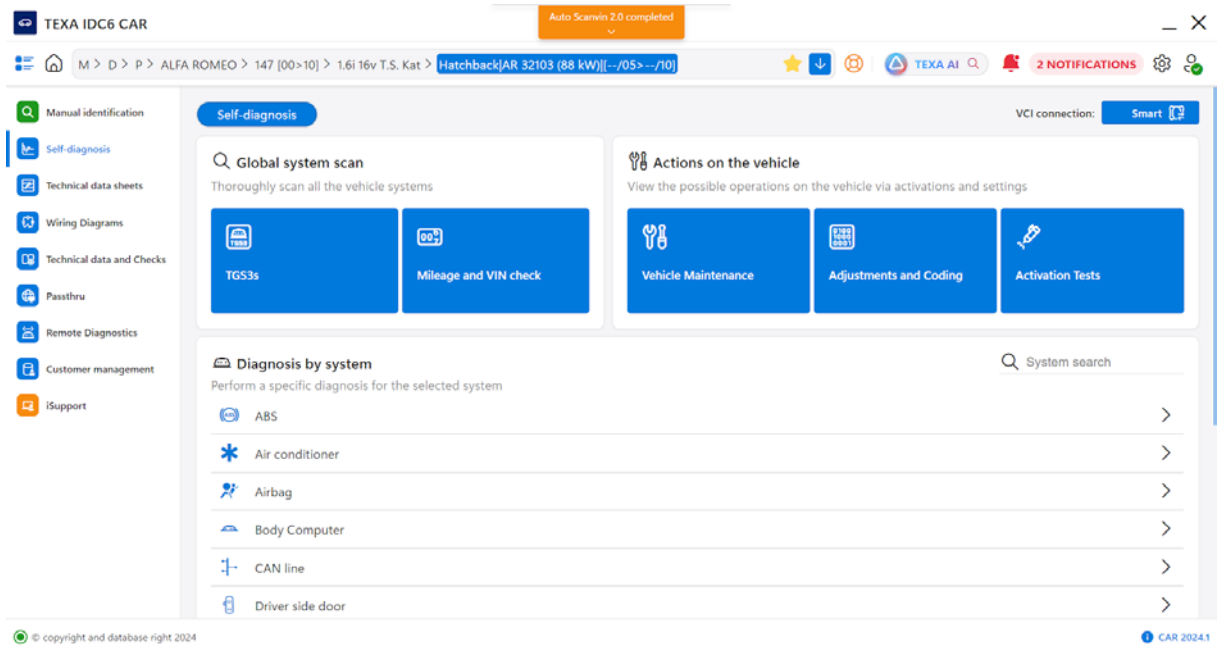

INFORMATION

To enter or remove a vehicle in the list of the selections saved, click on: 

6.2 News

This section contains information and news on the products and services offered by TEXA and on the availability of software updates.

INFORMATION

Once launched, the software checks for an active Internet connection and downloads all the latest information and news regarding the latest features available.

1. Press: 

The news screen is displayed.

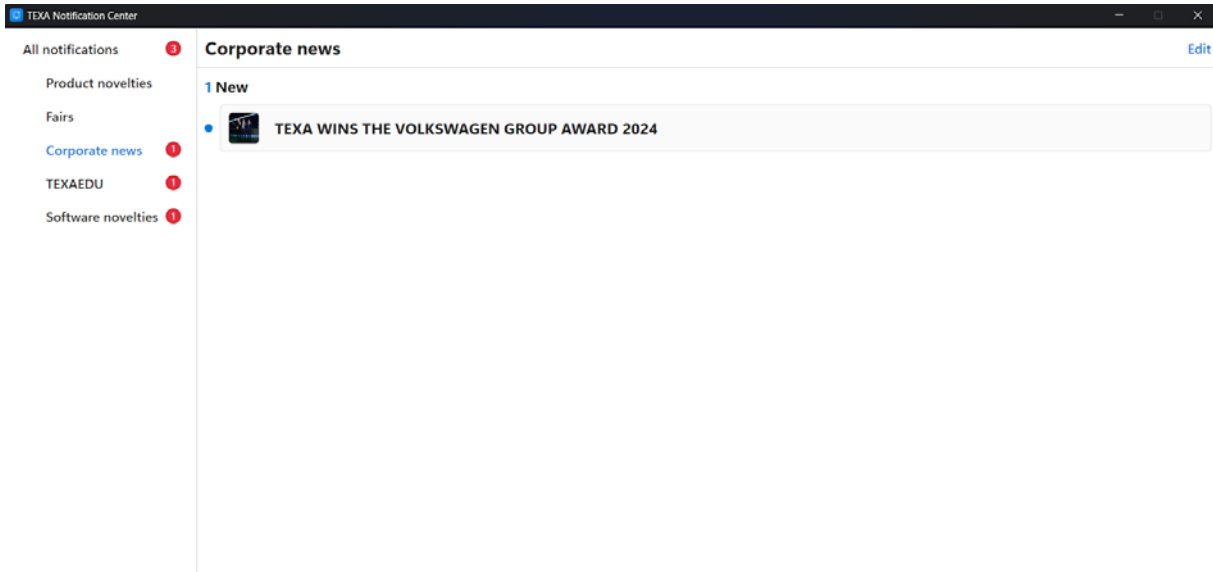

The news are divided by type.

2. Press on the desired news to display it.

6.3 Software information

To display the summary screen related to the status of the software subscriptions and services, click on the environment version number in the lower right corner of the **HOME** screen.

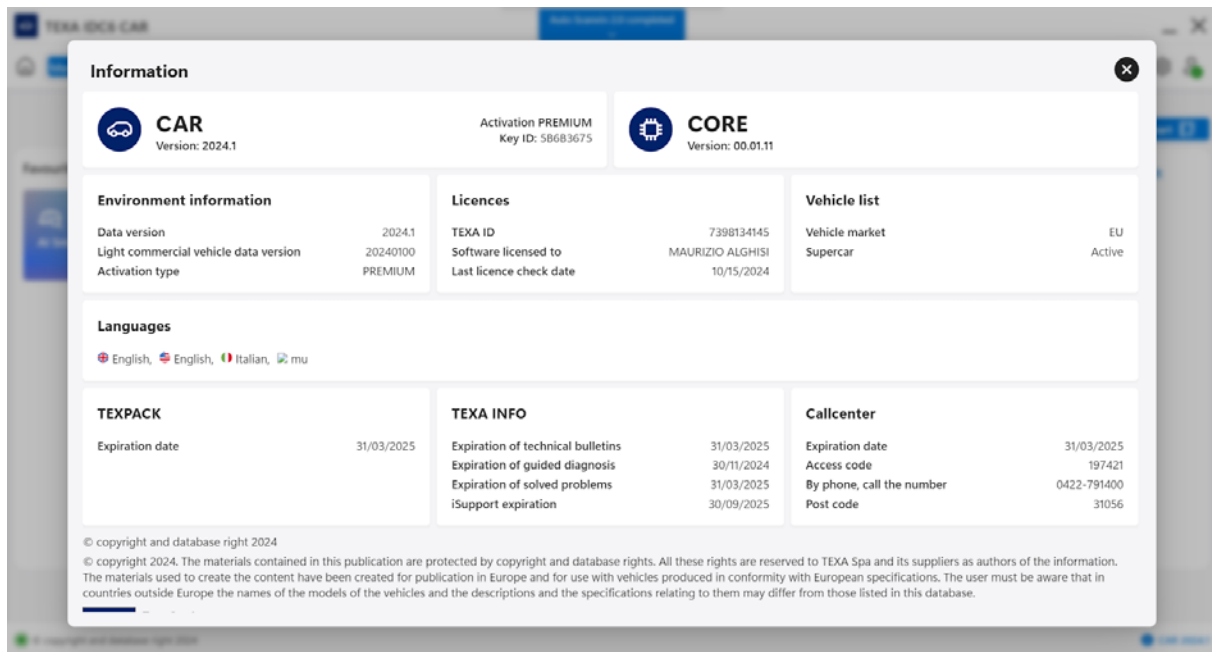

The information provided includes:

- *Software version*
- *Licences*
- *Vehicle list*
- *Languages*
- *Subscriptions to services*
- *Copyright*

INFORMATION

The information refers to the environment currently being used.

7 SETTINGS







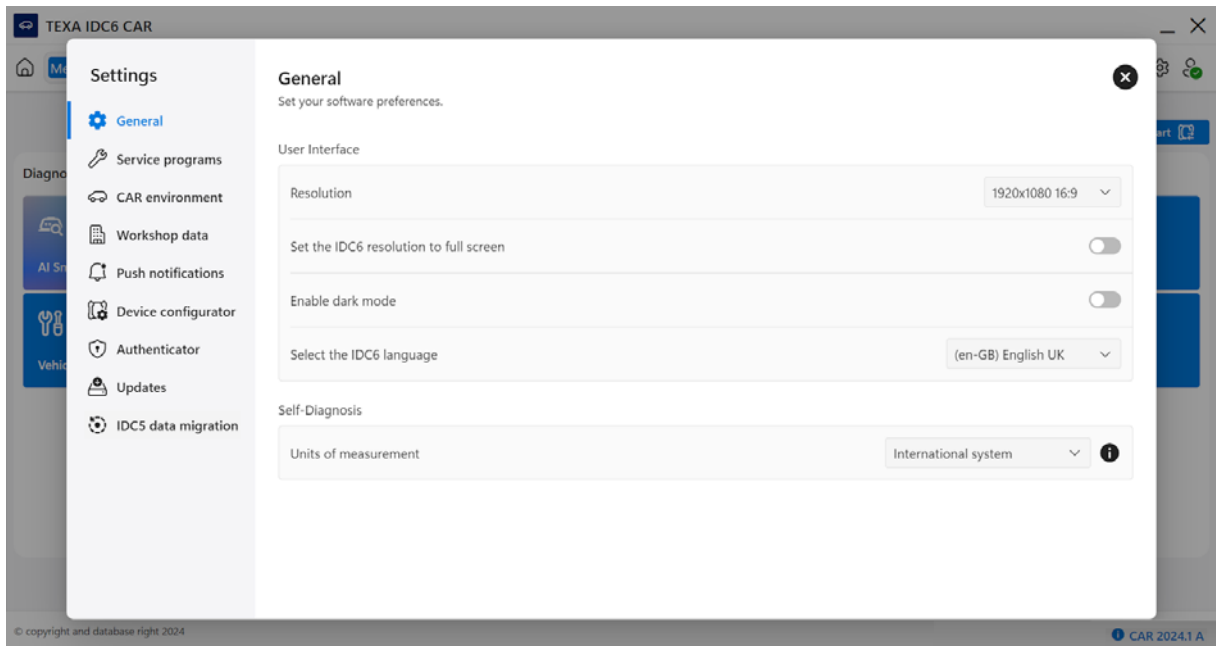

This function allows accessing the functions that are common to all the environments, such as language change and search for updates.



Proceed as follows:

1. Press: 



The screen is divided in the following sections:

Icon	Name	Description
	General	It allows setting your general preferences regarding the software.
	Service programs	It allows accessing a collection of programs and services that allow carrying out specific operations such as updating the device firmware programs and checking the network connection.
	Environment	It allows setting the specific software user preferences for the current environment. <i>Note: The icon varies based on the environment currently in use.</i>
	Workshop data	It allows entering the workshop data that will be displayed in the reports.
	Push notifications	It allows managing the reception and display of notifications while using the software.
	Device configurator	It allows adding new devices, displaying and changing the devices already configured.
	Authenticator	It allows managing the authentication for myTEXA.

	Updates	It allows setting your preferences for using the IDC6 Installer software related to: <ul style="list-style-type: none">• <i>Download(location, etc.)</i>• <i>Installation(automatic, etc.)</i>
	IDC5 data migration	It allows migrating your data (ex.: workshop database, configured devices) from IDC5 to IDC6.

7.1 General

In this section you can set your general preferences regarding the software.

You can set your preferences regarding:

- *User interface*
 - *Resolution;*
 - *Dark theme;*
 - *Display language;*
- *Self-diagnosis*
 - *Unit of measurement.*

Proceed as follows:

1. Press: 

The section of the general preferences is displayed.

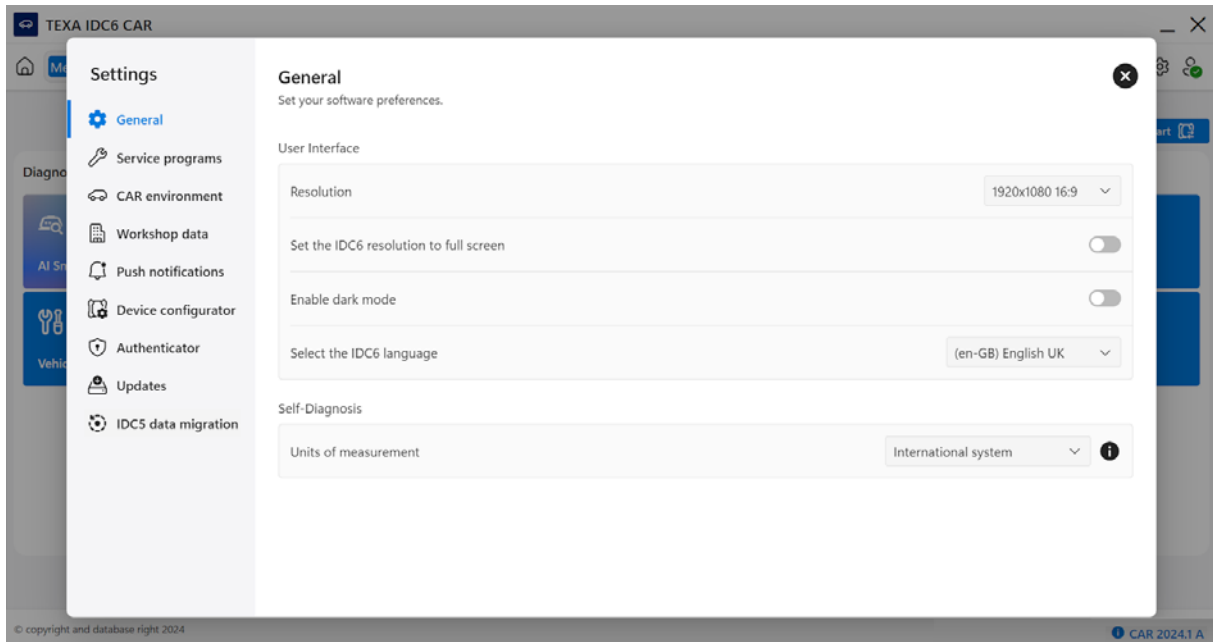

2. Carry out the desired settings.

7.1.1 Display language change

You can change the display language of the software.

Proceed as follows:

1. Press on the drop-down menu of the item: **Select the IDC6 language**
2. Select the desired language among the ones indicated.

INFORMATION

Only the purchased and installed languages are available.

3. Restart the software.

7.1.2 Changing the unit of measurement

You can change the system of measurement used by the software.

Proceed as follows:

1. Press: 
A guide on the units of measurement is displayed.

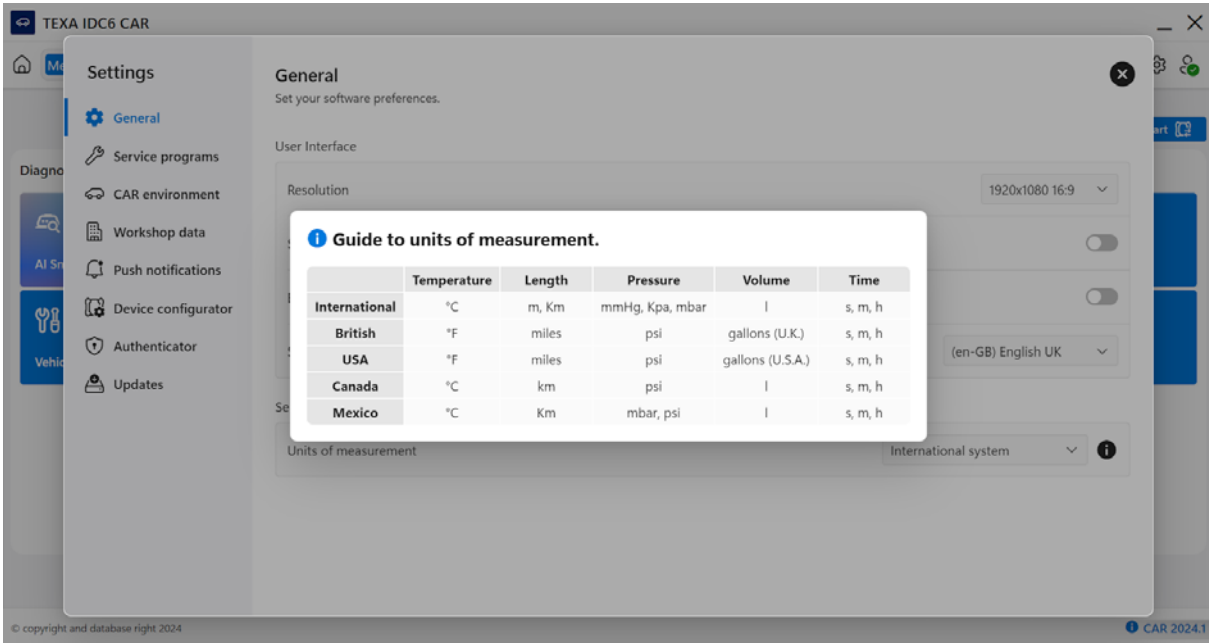

2. Press on any point on the screen to close the guide.
3. Press on the drop-down menu of the item: **Unit of measurement**
4. Select the desired system of measurement.

7.2 Service Programs

This section allows accessing a collection of programs and services that allow carrying out specific operations such as updating the device firmware programs and checking the network connection.

Proceed as follows:

1. Press: 

The collection is displayed.

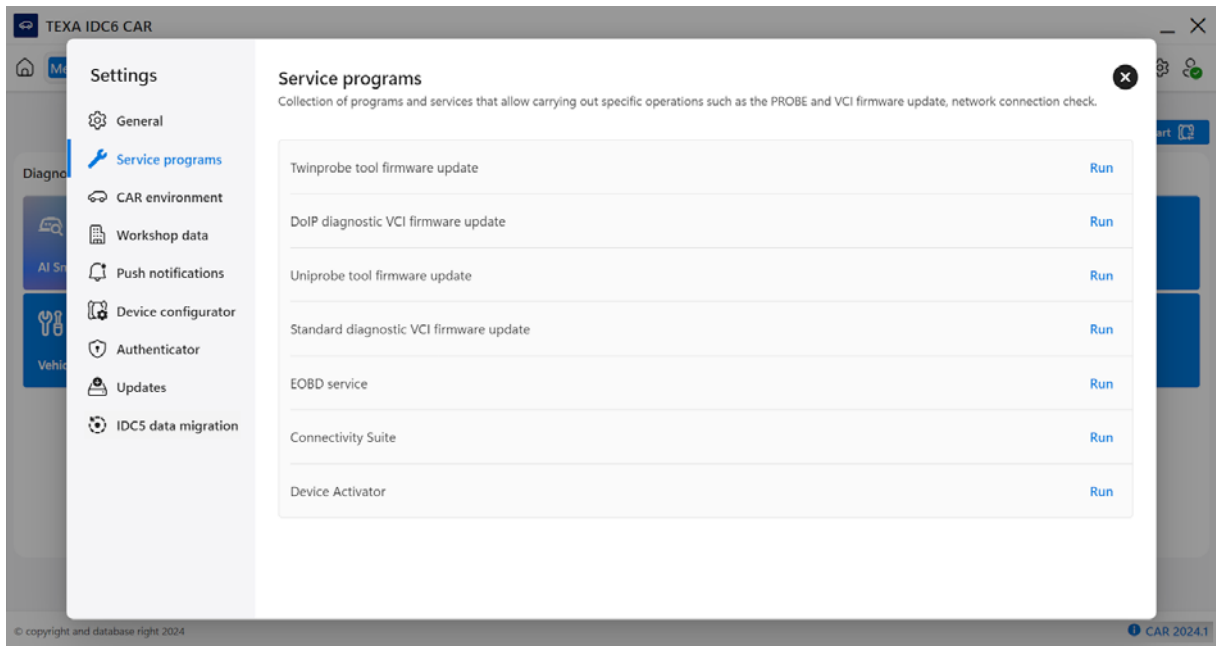

2. Press on the desired item.

INFORMATION

The available items vary based on the current environment.

7.2.1 Firmware update

The programs of this type allow launching a guided procedure for the firmware update specifically for the tool/VCI they refer to.

Proceed as follows:

1. Locate the desired item.
2. Press:**Run**

The function's main screen is displayed.



3. Follow the instructions that appear on screen.



This function allows learning the serial number of the device configured for the use of the EOBD Protocol and the firmware/diagnostic system version.

Through this function you can change the selected device and assign a COM to it.

INFORMATION

The new device must be chosen among the ones configured through the Device Configurator function.

Proceed as follows:

1. Locate the desired item.
2. Press: **Run**

The function's main screen is displayed.

Scantool identification information

Serial number	Version
DNIBT000018	2.0.0.0

Scantool configuration

Tool selection	COM selection
Navigator TXT Series	COM4

Under the Scantool Identification Information item the following can be found:

- *serial number of the device;*
- *firmware / diagnostic system version.*

Under the Scantool Configuration item there are two drop-down menus through which you can set:

- *the device you wish to use;*
- *the COM you wish to assign the selected device to.*

7.2.3 Connectivity suite

This function allows running tests on the online services.

Proceed as follows:

1. Locate the desired item.
2. Press:**Run**

The function's main screen is displayed.

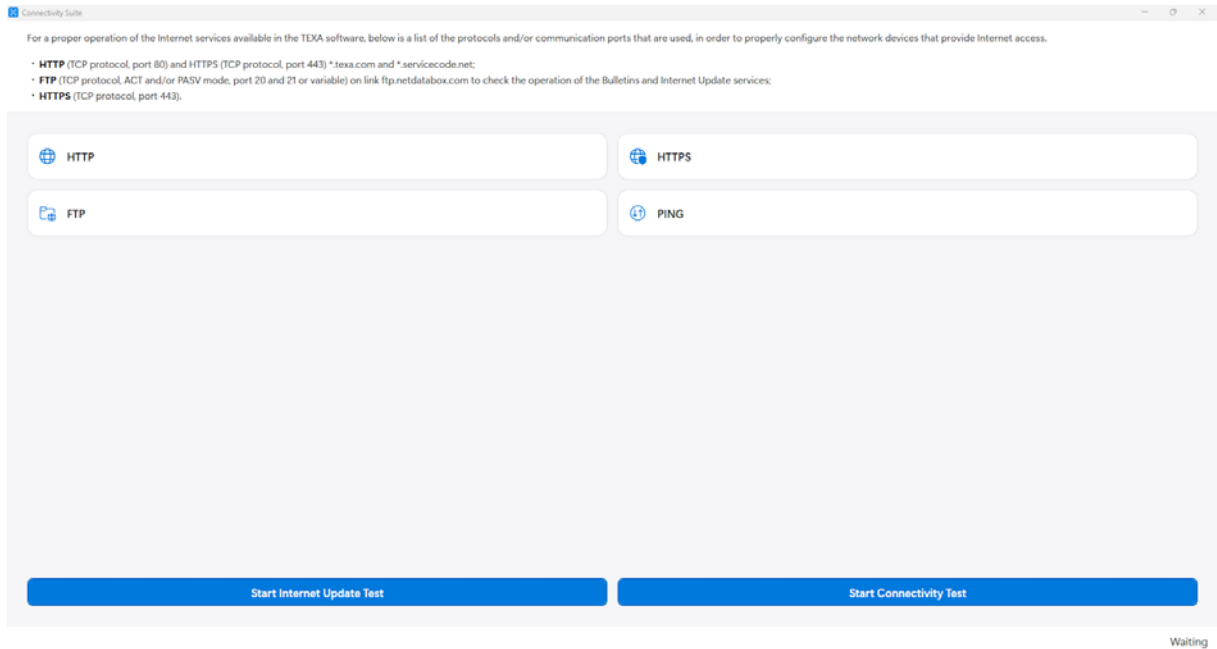

3. Press on the icon related to the test you wish to run.

The test is started and the result is displayed automatically.

7.2.4 Device activator



This function allows forcing the update of the list of purchased ADAS products and activating them. Updating the list allows the software to learn which products are available for the operations on systems/ADAS.

INFORMATION

However, the products that requires a wireless connection to the display unit must be configured before being able to use them.

*For further information, see the chapter: **Device configurator***

Proceed as follows:

1. Locate the desired item.
2. Press: **Run**

The result is displayed.

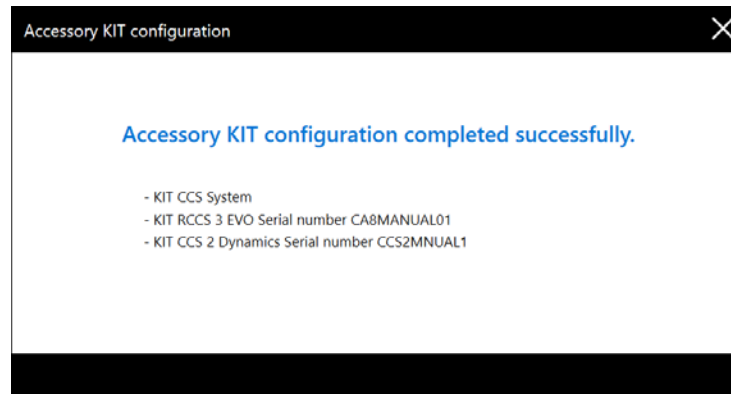

7.3 Environment

In this section you can set the specific software user preferences for the current environment. In particular, you can enable or disable the display of:

- *notifications*
- *disclaimers*
- *etc.*

Proceed as follows:

1. Press: 

The section of the preferences for the current environment is displayed.

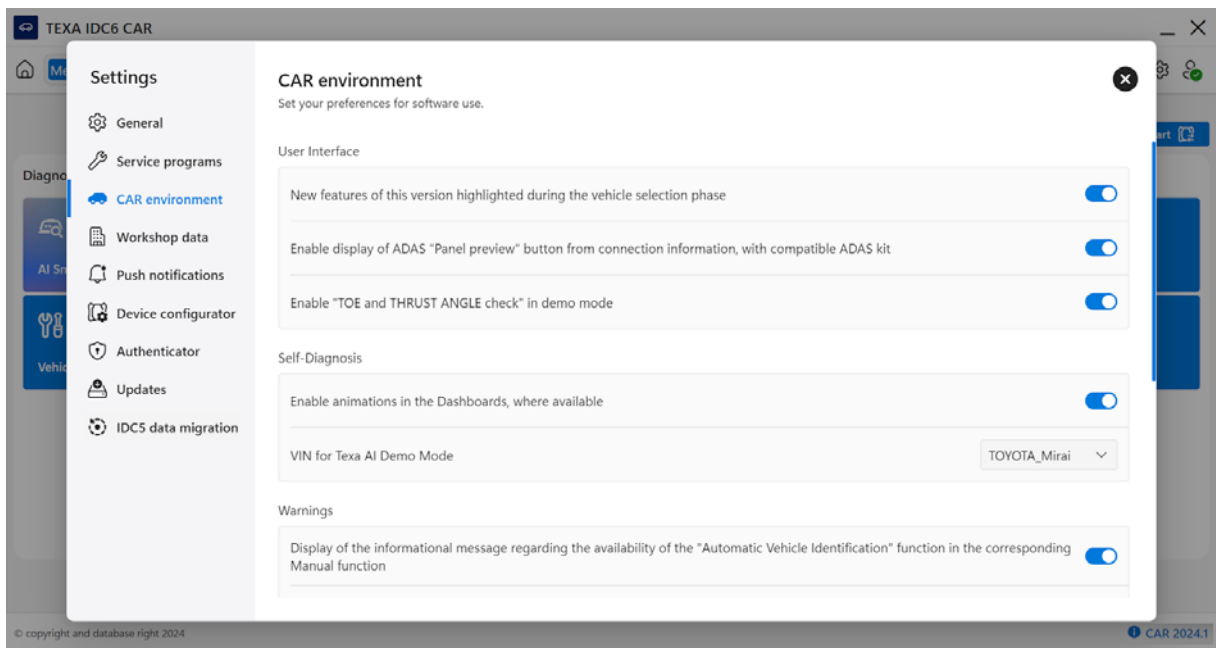

2. Carry out the desired settings.

7.4 Workshop data

In this section you can enter the workshop data that will be printed in the reports.

Proceed as follows:

1. Press: 

The workshop data entry section is displayed.

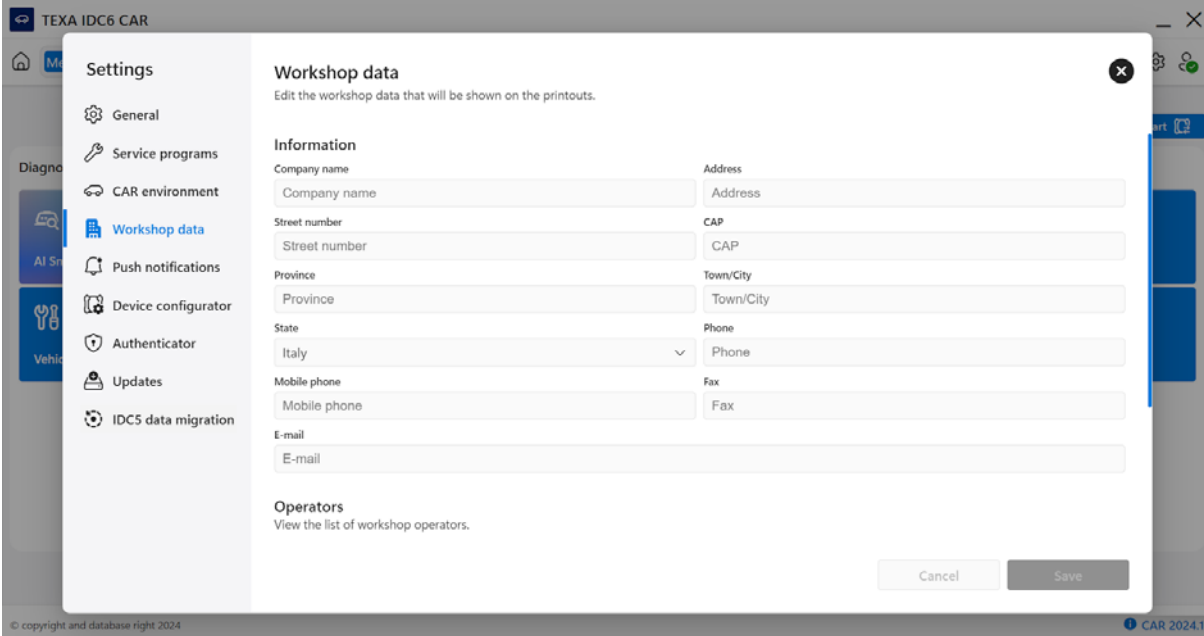

TEXA IDC6 CAR

Settings

- General
- Service programs
- CAR environment
- Workshop data**
- Push notifications
- Device configurator
- Authenticator
- Updates
- IDC5 data migration

Workshop data

Edit the workshop data that will be shown on the printouts.

Information

Company name	Address
Company name	Address
Street number	CAP
Street number	CAP
Province	Town/City
Province	Town/City
State	Phone
Italy	Phone
Mobile phone	Fax
Mobile phone	Fax
E-mail	
E-mail	

Operators

View the list of workshop operators.

Cancel Save

© copyright and database right 2024 CAR 2024.1

2. Enter the workshop data.

3. Press: **Save**

7.5 Push Notifications

This section allows managing the reception and display of notifications while using the software. Proceed as follows:

1. Press: 

The section for managing the push notifications is displayed.

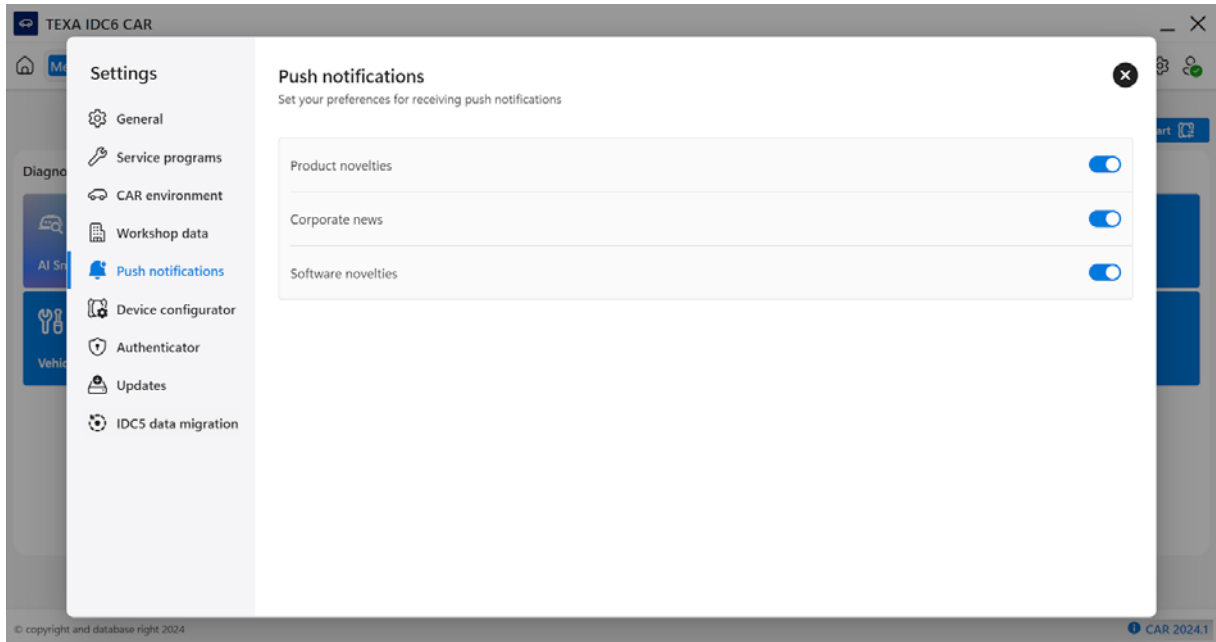

3. Carry out the desired settings.

7.6 Device Configurator

This function allows configuring the communication between a device (ex.: VCI) and the display unit in which the software is installed.

Once the type of device is recognised, the software suggests to configure the communication in all the modes available (ex.: USB, Bluetooth, Wi-Fi).

By configuring all the modes available, when the display unit tries to connect to the device, the software autonomously selects the best option available.

INFORMATION

You can also just select one of the communication modes available, however we recommend configuring all of them.

INFORMATION

Make sure the device has been powered and switch on correctly before launching the configuration procedure.

INFORMATION

For the configuration of the communication via Wi-Fi to be successful, the device and the display unit must be part of the same Wi-Fi network.



For further information on the connection modes of a specific device, see the related technical manual.

Proceed as follows:

1. Press: 

2. Press: **Start Device Configurator**

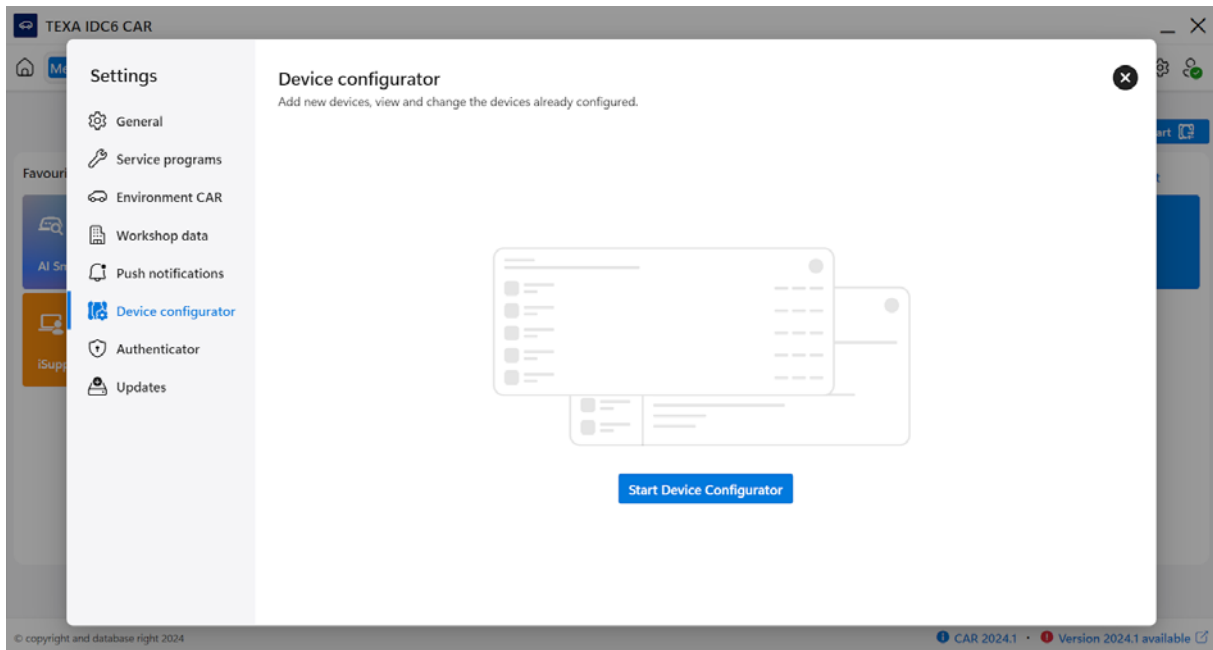

3. Press: Add a new device

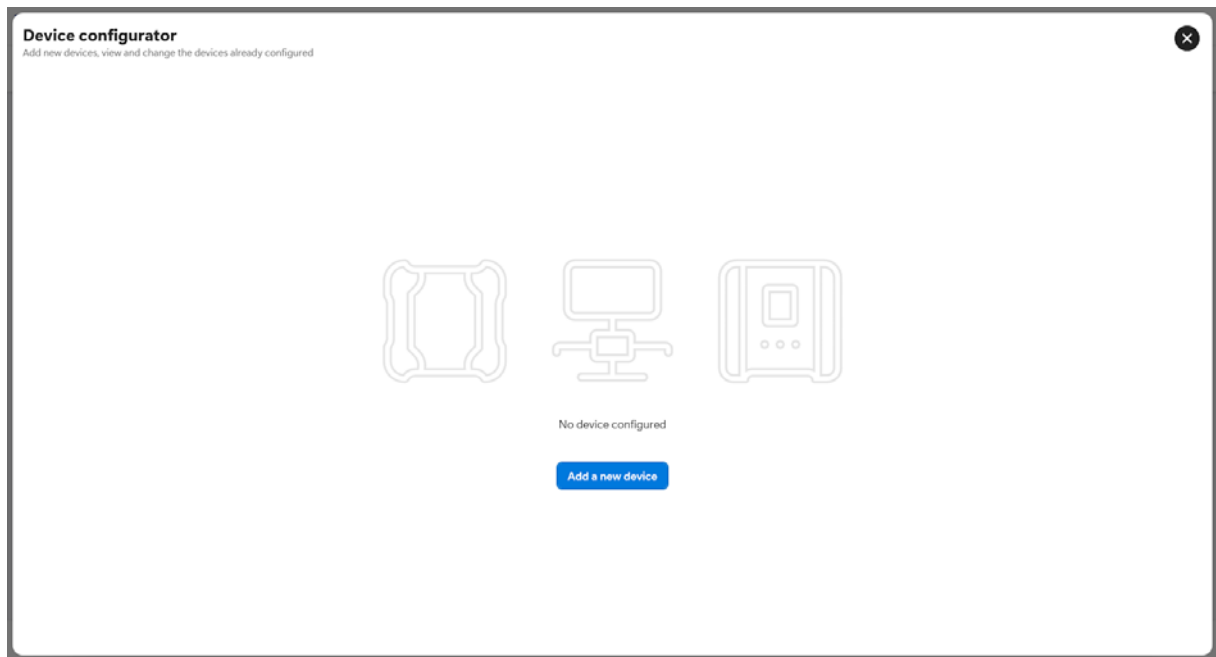

4. Select the desired device among the ones detected.

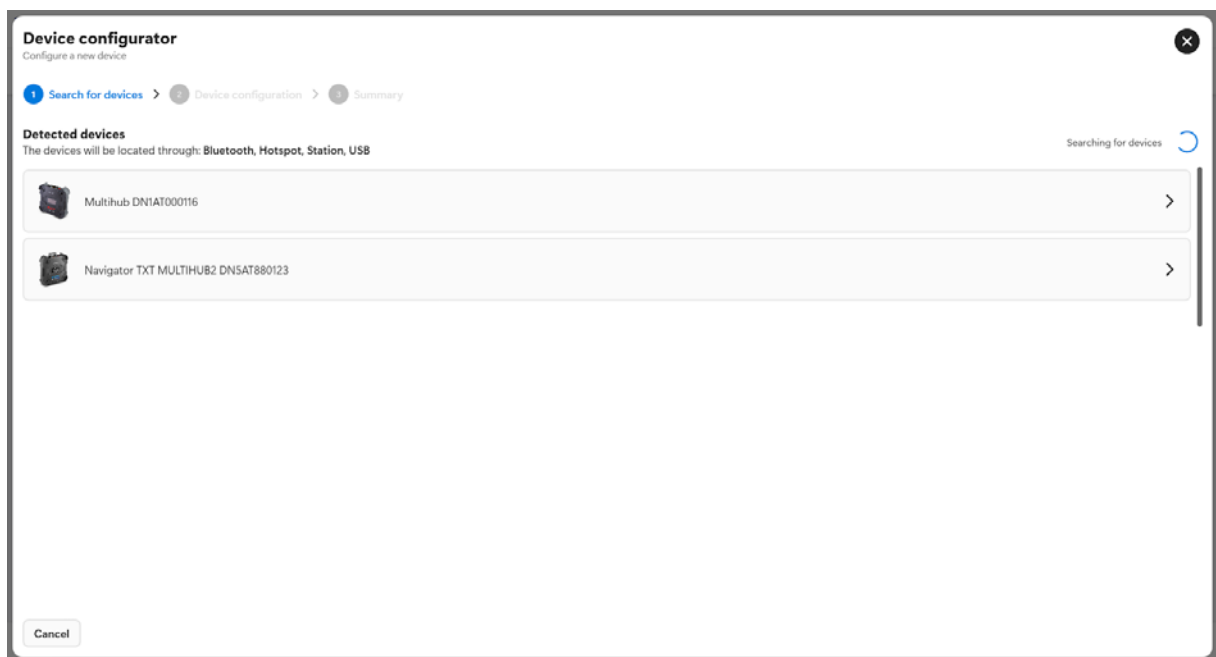

INFORMATION

Only the devices supported by the current environment are displayed.

5. The communication via USB is configured.

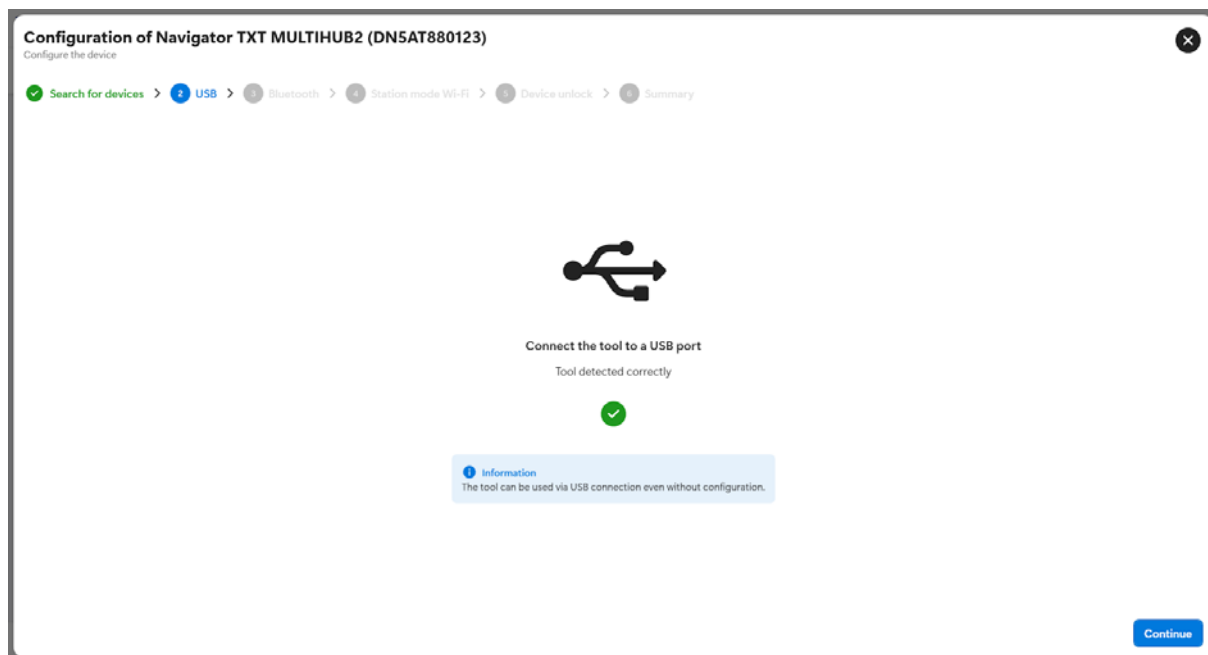

6. The communication via Bluetooth is configured.

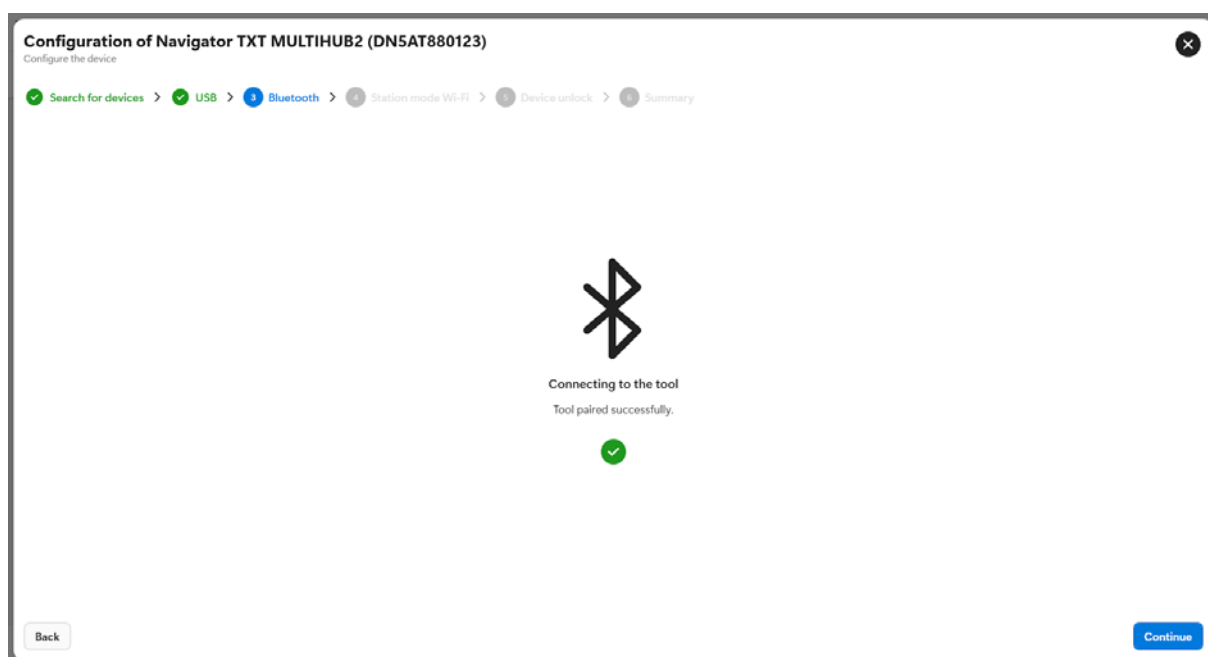

- The list of the detected Wi-Fi networks is displayed.
Select the desired network.

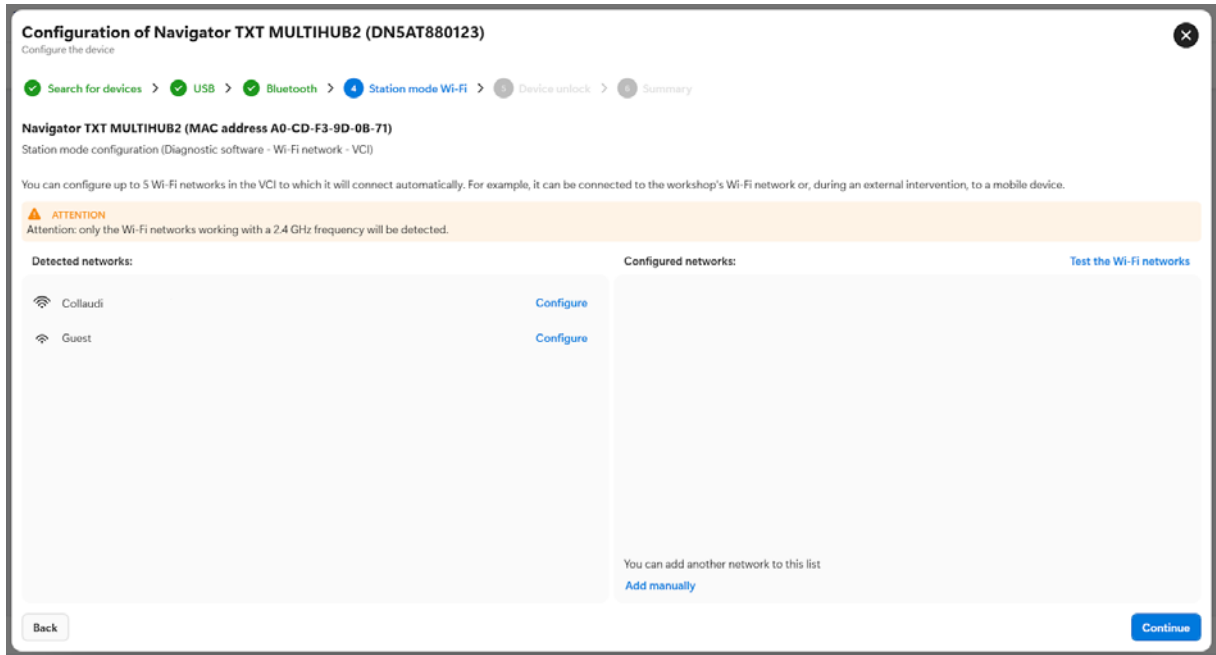

- Enter the network login password if required.
Press: **Save**

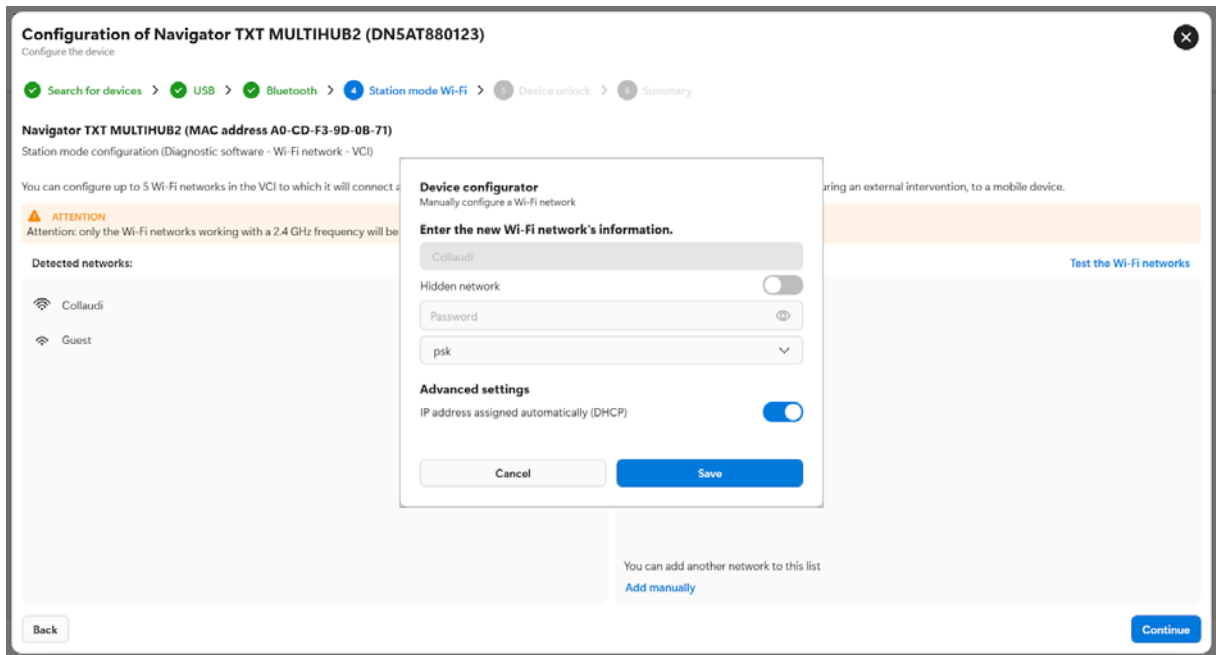

9. The network is added to the list of configured networks.

Press: **Continue**

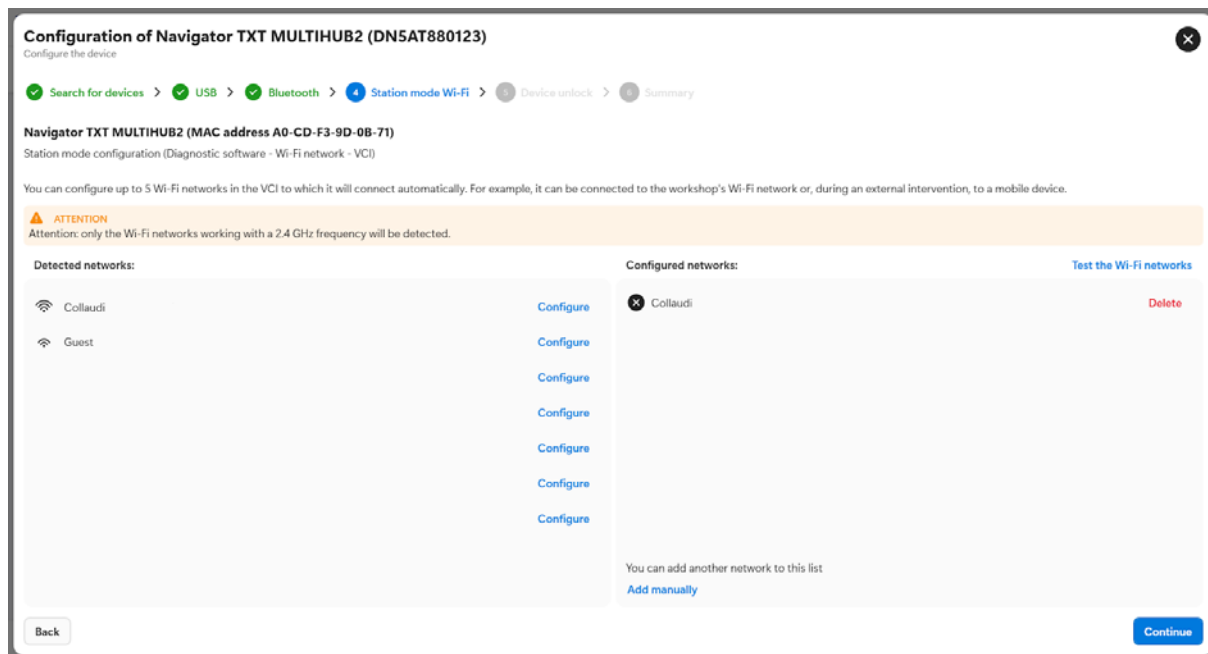

10. The device is unlocked.

Press: **Continue**

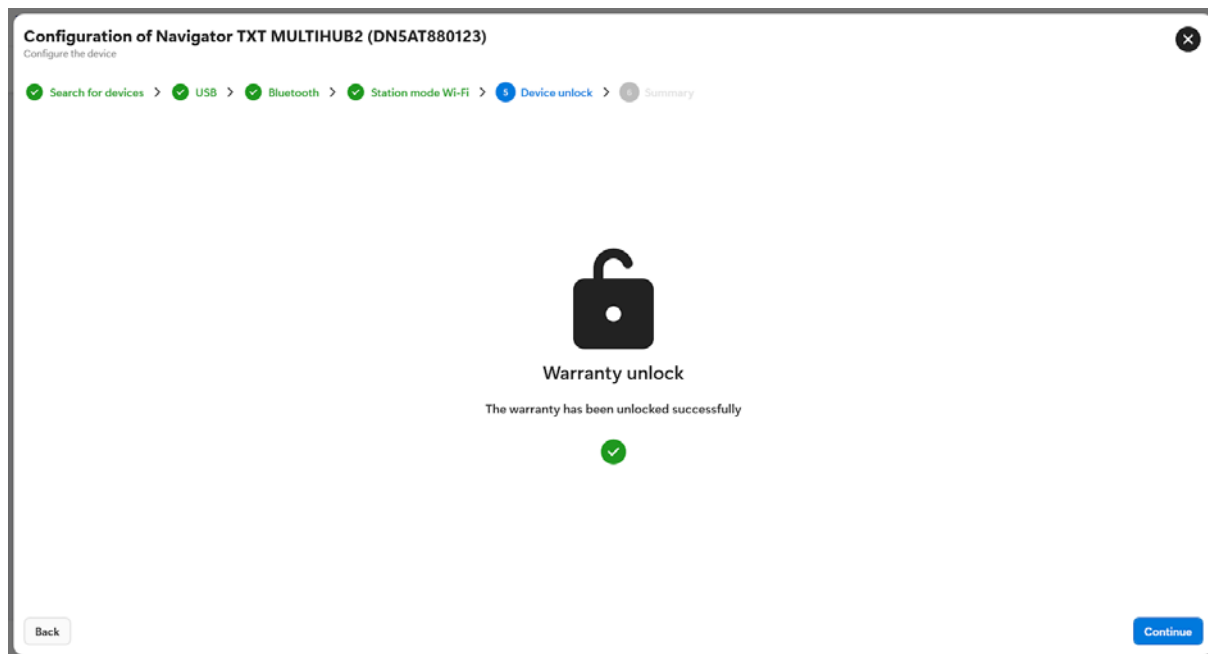

11. The configuration summary screen is displayed.

Press: **End**

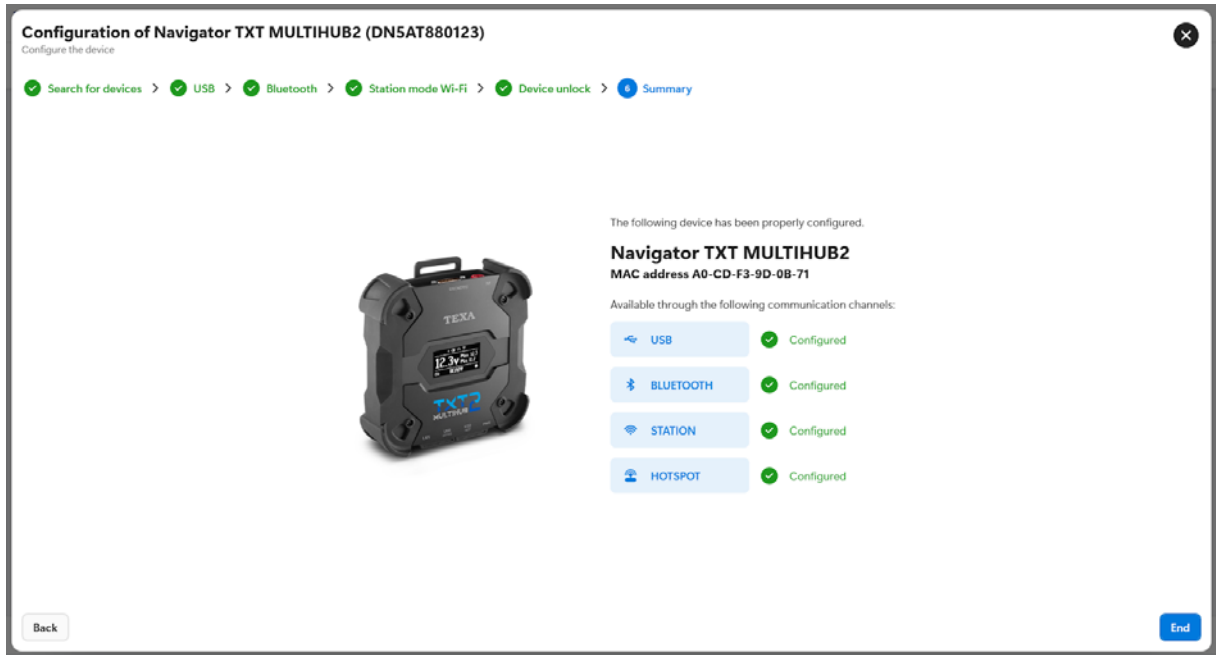

12. The list of devices currently configured is displayed.

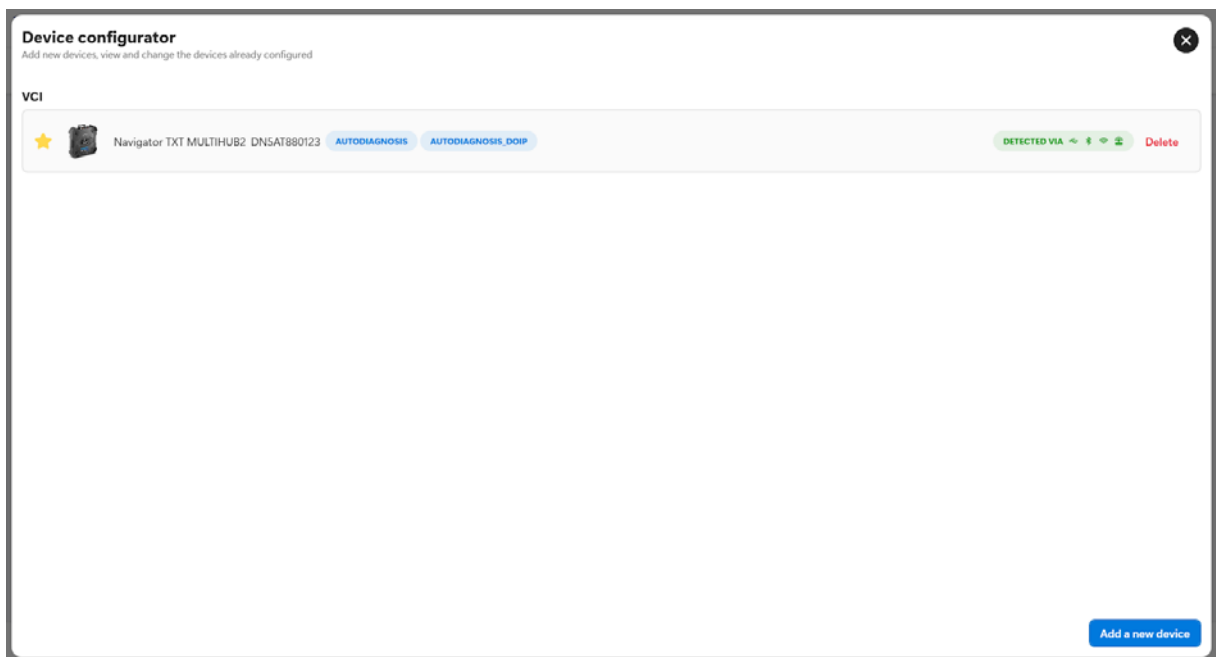

INFORMATION

To indicate the preference to use between two or more similar devices (ex.: VCI) configured for the same function, click on: 
The indication is only valid for the current environment.
You can indicate a different preferred device (ex.: VCI) for each environment as long as it has been configured correctly.

7.7 Authenticator

This function allows managing the authentication for myTEXA.

The authenticated diagnosis allows unlocking the gateways or control units inhibited by the manufacturers.

To access the authenticated diagnosis function, each operator must have a personal account.

Proceed as follows:

1. Press: 

The function's main screen is displayed.

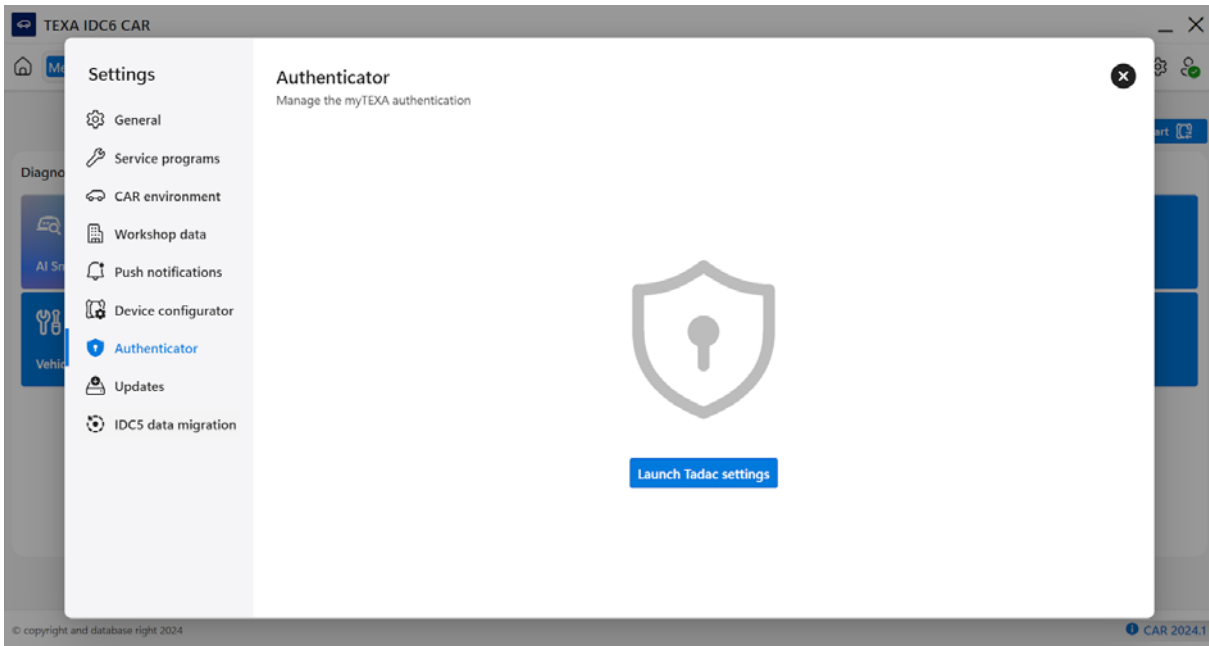

2. Press: **Launch Tdac settings**
3. Follow the instructions that appear on screen.

7.8 Updates

In this section you can set your preferences for using the IDC6 Installer software related to:

- *Download*
- *Installation*

For example, you can:

- *specify the position in which the updates must be downloaded;*
- *enable the automatic update download;*
- *enable the automatic update installation;*
- *etc.*

Proceed as follows:

1. Press: 

The section for setting your preferences for using the IDC6 Installer software is displayed.

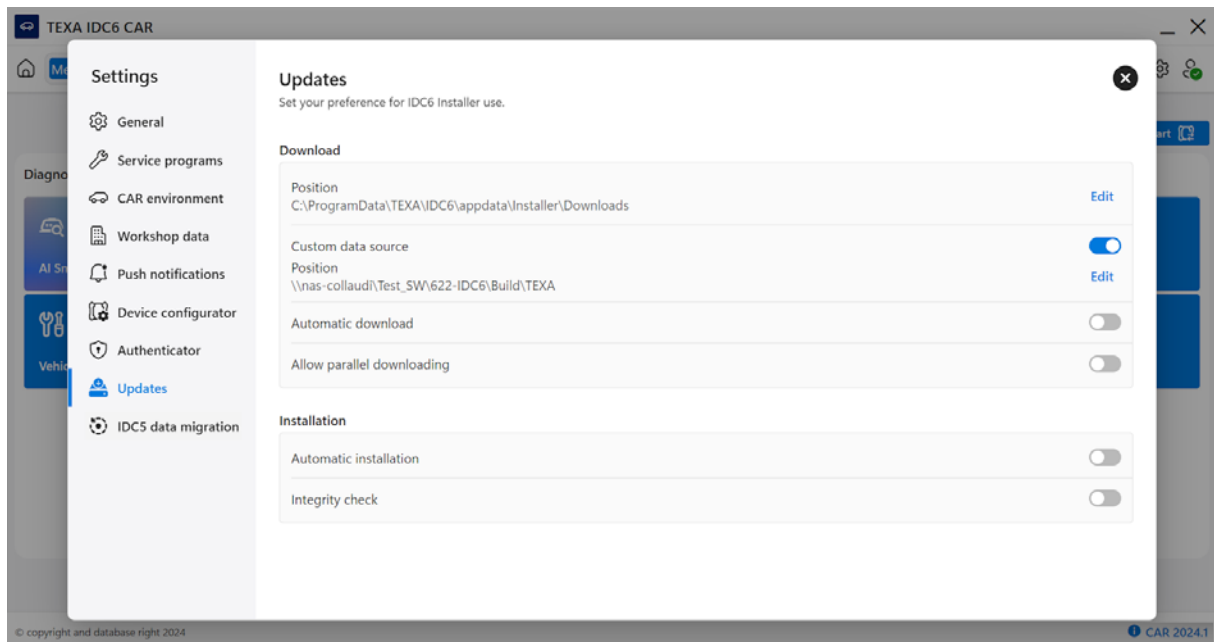

2. Carry out the desired settings.

7.9 IDC5 Data Migration

This function allows migrating your data (ex.: workshop database, configured devices) from IDC5 to IDC6.

INFORMATION

The function is only available if an error occurred in at least one of the environments updated from IDC5 to IDC6.

Proceed as follows:

1. Press: 

The function's main screen is displayed.

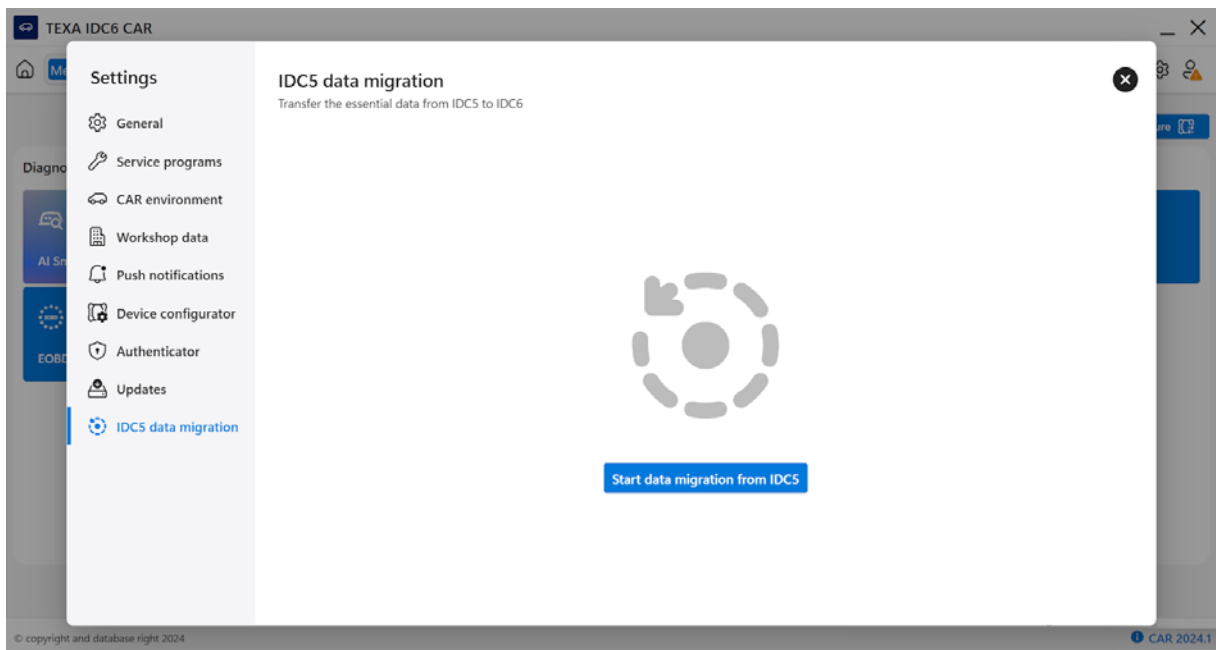

2. Press: **Start data migration from IDC5**
3. Follow the instructions that appear on screen.

8 VCI CONNECTION



The software and the VCI can be connected using one of the following modes:

Mode	Description
Smart	The software autonomously selects the best option available among the configured communication modes. The selection is made each time based on the quality of the signal, the type of diagnosis and other factors. Recommended selection.
Manual	The operator manually selects the connection mode between the configured communication modes.

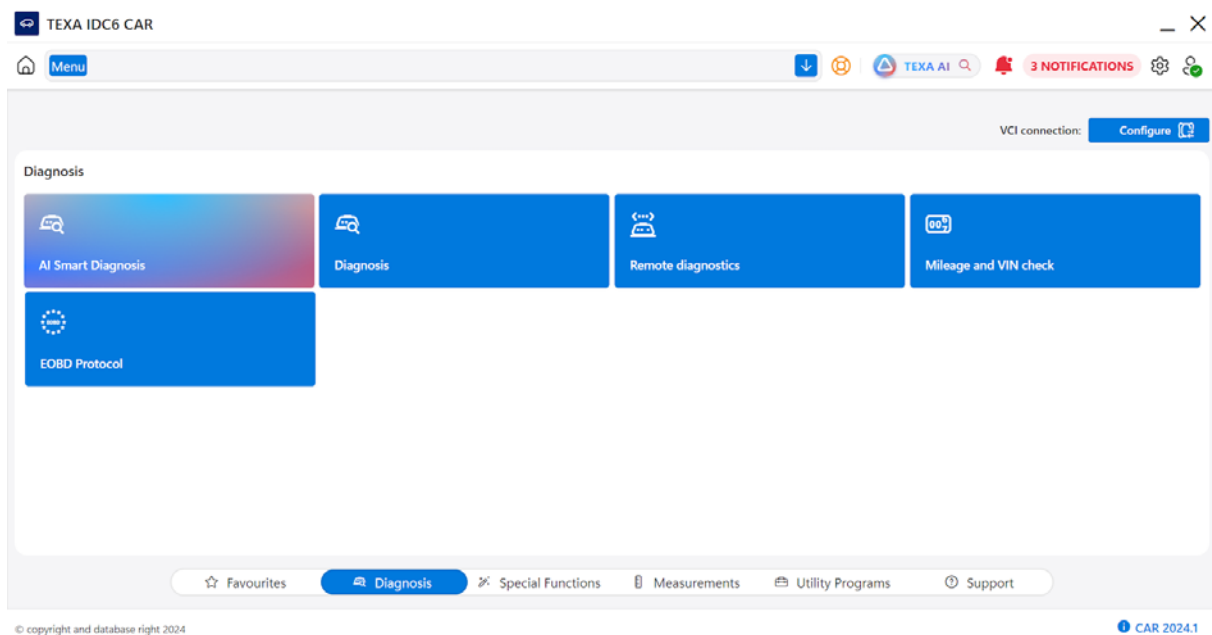

INFORMATION

At the end of the configuration of a VCI, the smart connection mode is set by default.

The connection modes can be changed at any time.

Proceed as follows:

1. Press: 
2. Press: **Manual**

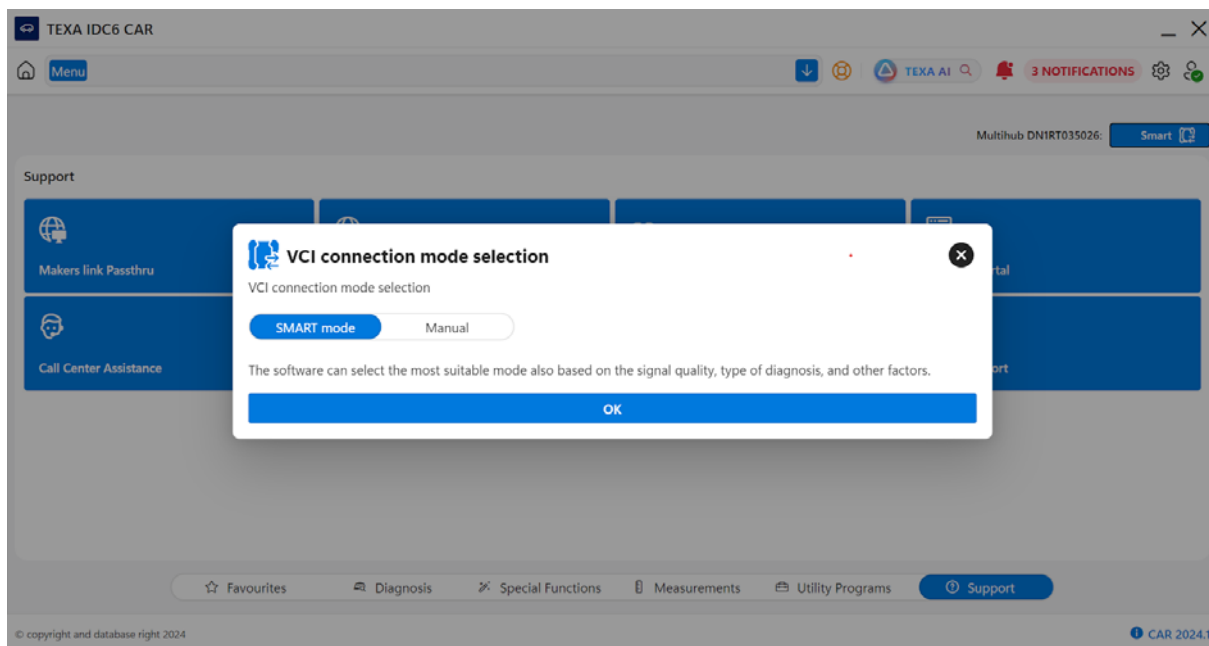

3. Select the desired connection modes.

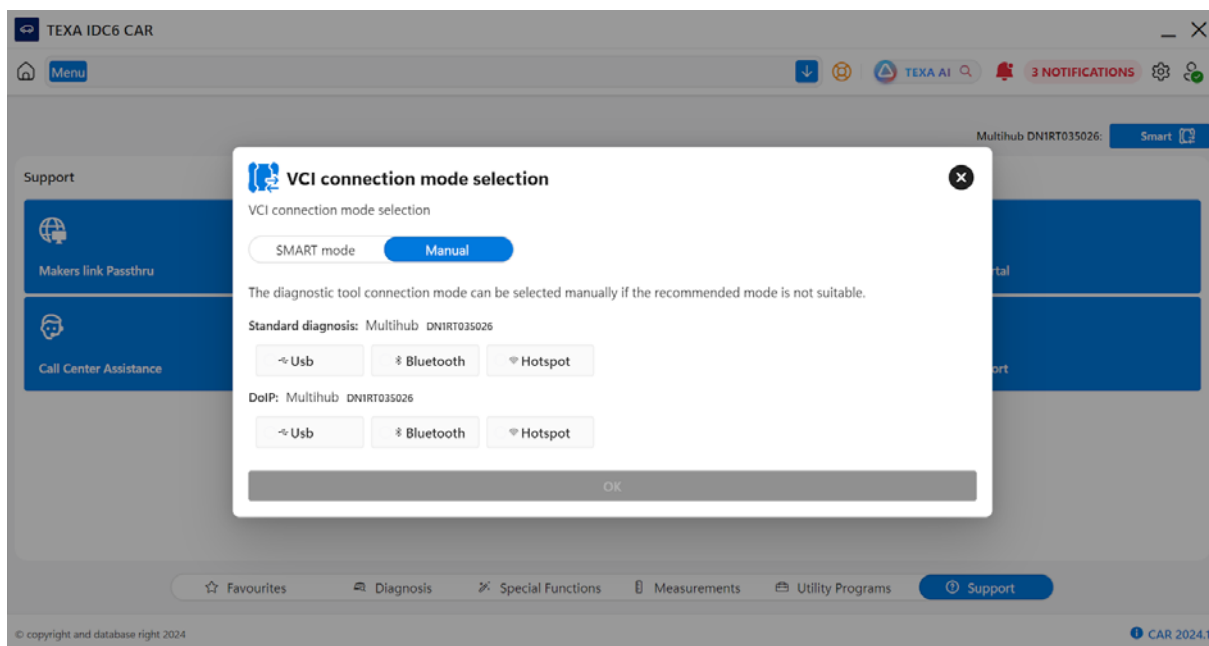

4. Press:OK

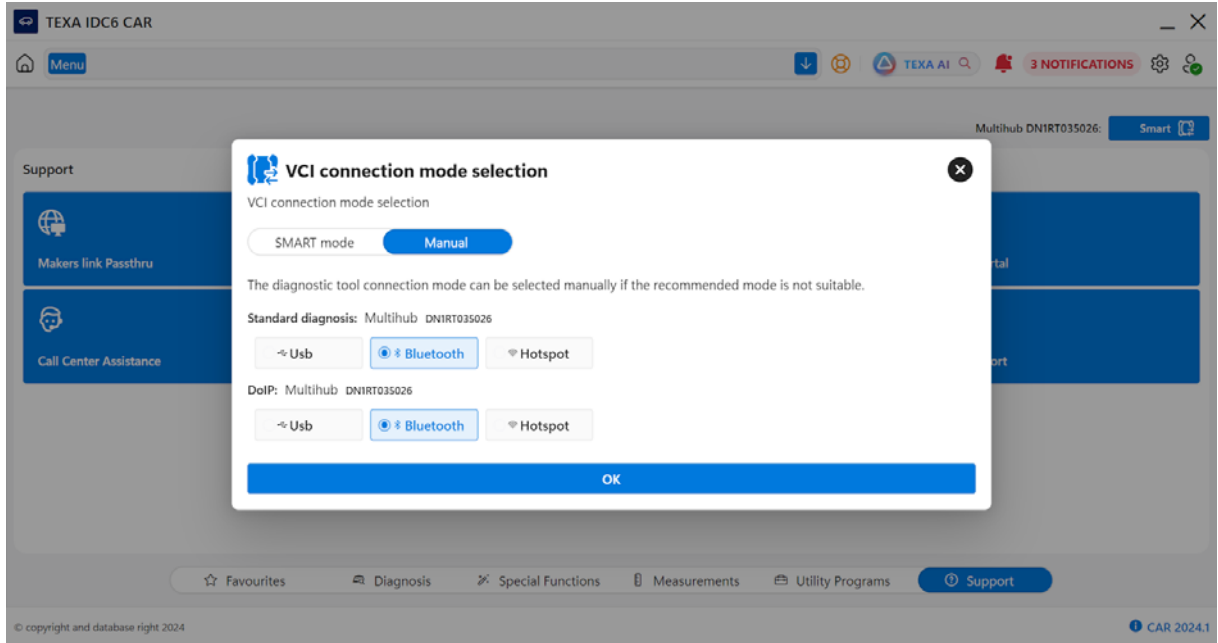

9 TECHNICAL SUPPORT



The icons in this menu allow accessing the menu for technical support functions, among which the transmission of an assistance request.

Proceed as follows:

1. Press: 

The function's Home screen is displayed.

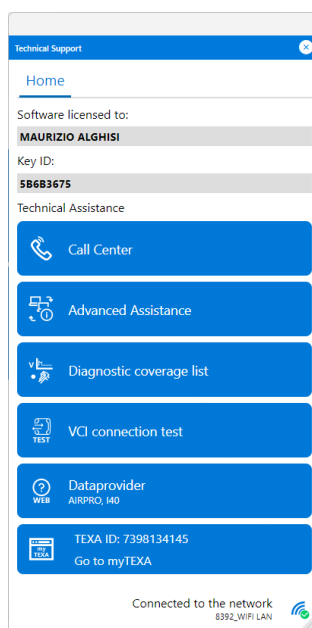

The following information is indicated in this screen:

- owner of the software user license;
- ID of the HASP key currently in use.

The following functions are available:

Name	Description
Call Center	It allows accessing the web portal for the Call Center assistance requests.
Advanced Assistance	It allows accessing the menu with the Advanced Assistance functions, among which the remote assistance.
Diagnostic coverage list	It allows accessing the list of vehicles, systems and new features available in the installed version of the current environment.
VCI connection test	It allows carrying out an operating test on the connections of the VCIs and to communicate the result to the technical assistance service.
Data provider	It allows accessing a specific assistance portal.
myTEXA	It allows viewing your TEXA ID and accessing the myTEXA portal.
Connection	It allows accessing the configuration functions to connect to the workshop's Wi-Fi network.

INFORMATION

To use the connection functions you must have an active software subscription.

Check with your retailer if the service is active in the country you wish to use it in.

9.1 Call Center

It allows accessing the web portal for the Call Center assistance requests.

Proceed as follows:

1. Press: **Call Center**

Useful information is displayed, among which:

- *Key ID;*
- *Specifications of the environment currently in use;*
- *Call Center phone number;*
- *Access Code.*

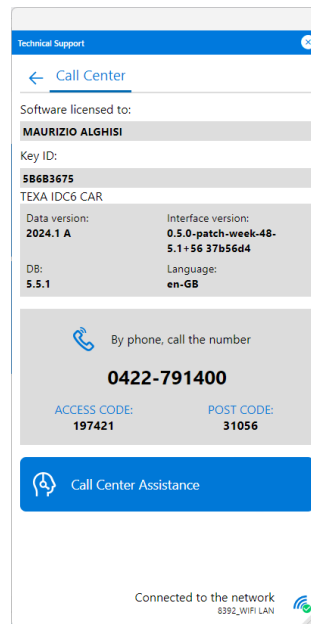

2. Press: **Call Center Assistance**

The web portal for the Call Center assistance requests is displayed.

For further information, see the chapter: **Call Center Assistance**

9.2 Advanced Assistance

This function allows accessing the menu with the Advanced Assistance functions, among which the remote assistance.

Proceed as follows:

1. Press: **Advanced assistance**

Useful information is displayed, among which:

- *Key ID;*
- *Specifications of the environment currently in use.*

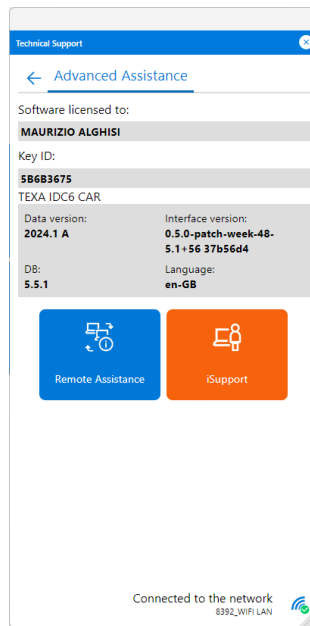

The following functions are available:

Name	Description
Remote assistance	It allows requesting remote assistance in real time through TeamViewer on your diagnostic device.
iSupport	It allows sending support and/or specific diagnostic content development requests.

2. Select the desired option.

9.3 Diagnostic Coverage List

This function allows accessing the list of vehicles, systems and new features available in the installed version of the current environment.

Proceed as follows:

1. Press: **Diagnostic coverage list**

The Diagnostic Coverage List is displayed.

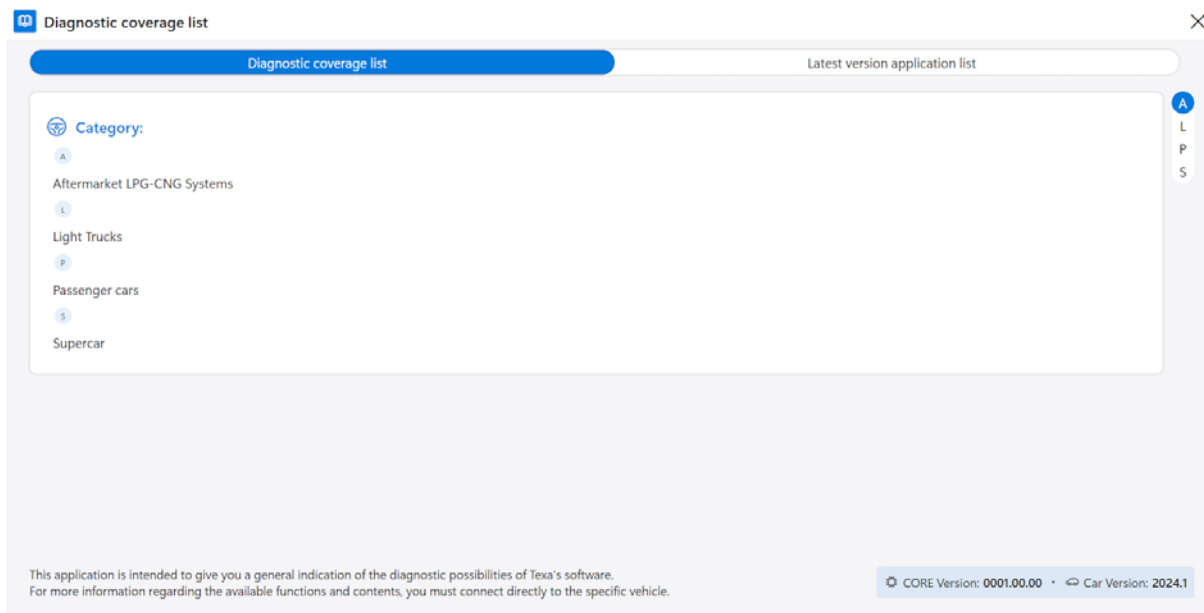

The following sections are available:

Name	Description
Diagnostic coverage list	It allows accessing the complete list of vehicles on which diagnostic operations can be carried out through the software version currently installed.
New feature list of the latest version	<p>It allows accessing the list of new features available in the software version currently installed.</p> <p>It is divided in:</p> <ul style="list-style-type: none"> • <i>Diagnosis</i> • <i>Vehicle maintenance</i> • <i>Technical sheets</i> • <i>Wiring diagrams</i>

2. Press on the desired section.

3. Select the desired information.

9.4 VCI Connection Test

This function allows carrying out an operating test on the connections of the VCIs and communicating the result to the technical assistance service.

Proceed as follows:

1. Press:**VCI Connection Test**

The VCI Connection Test screen is displayed.

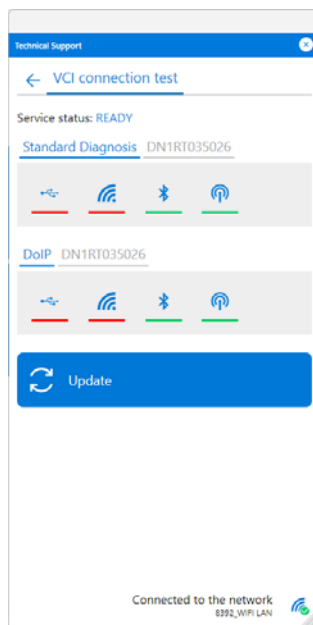

2. Press:**Update**

The test is started and the result is displayed automatically.

9.5 Dataprovider

This function allows accessing a specific assistance portal.

INFORMATION

The function must be used only if indicated to do so by the Technical Assistance.

Proceed as follows:

1. Press:**Dataprovider**

The login screen is displayed.

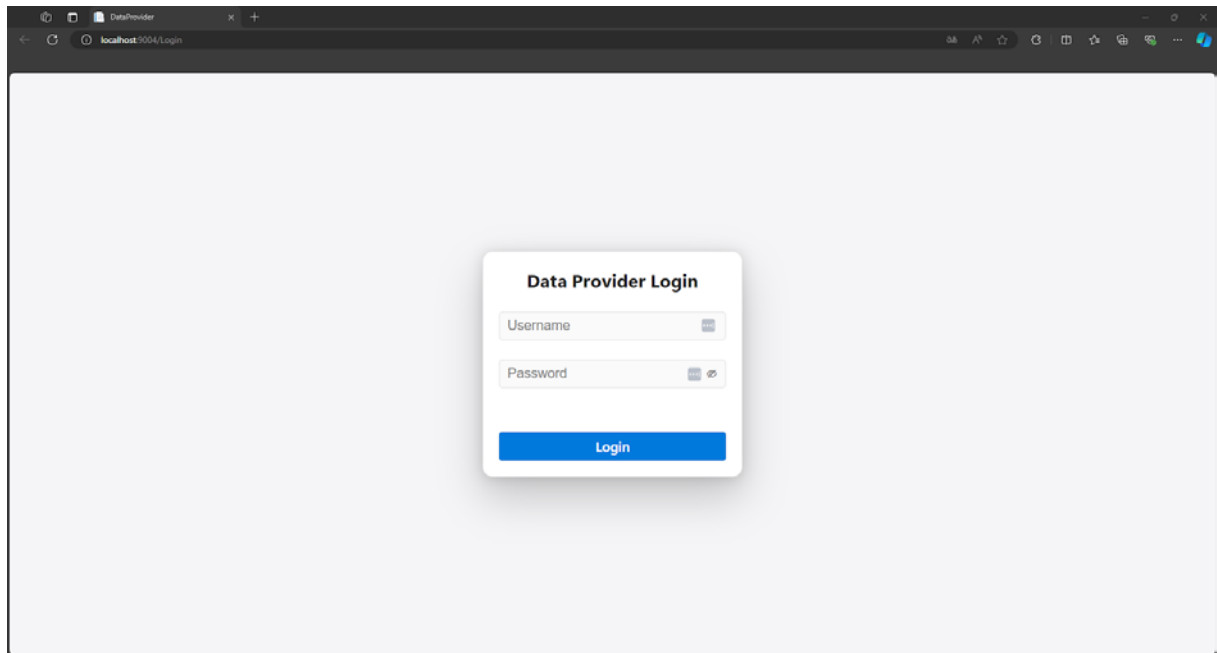

2. Enter the login credentials.

3. Press:**Login**

4. Follow the instructions provided by the Technical Assistance.

9.6 *myTEXA*

This function allows viewing your TEXA ID and accessing the myTEXA portal.

For further information, see the chapter:myTEXA

9.7 Connection

This menu allows accessing the configuration functions to connect to the workshop's Wi-Fi network.

Proceed as follows:

1. Press: **Connection**

The Connection screen is displayed.

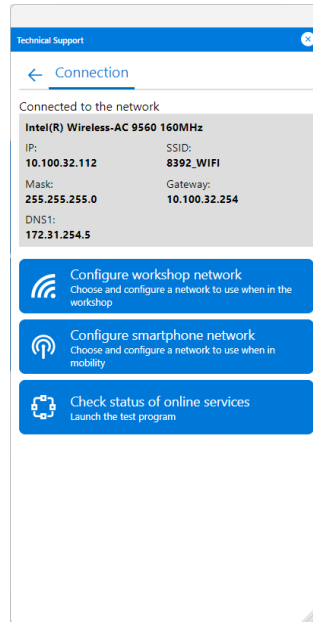

The following information is indicated in this screen:

- *Connection status*
- *Network parameters*

The following functions are available:

Name	Description
Configure workshop network	It allows choosing and configuring a network to use when in the workshop.
Configure smartphone network	It allows choosing and configuring a network to use when in mobility.
Check status of online services	It allows running a test on the online services.

9.7.1 Configure workshop network

This function allows choosing and configuring a network to use when in the workshop.

Proceed as follows:

1. Press: **Configure workshop network**

The Connection screen is displayed.

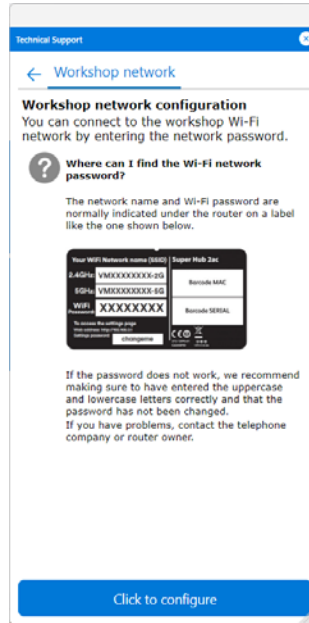

2. Press: **Press to configure**

A procedure for configuring the connection to the workshop's Wi-Fi network is started.

3. Follow the instructions that appear on screen.

9.7.2 Configure smartphone network

This function allows choosing and configuring a network to use when in mobility.

Proceed as follows:

1. Press: **Configure smartphone network**

The Connection screen is displayed.

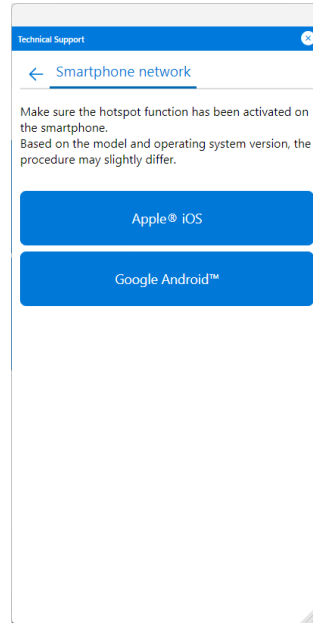

2. Follow the instructions that appear on screen.
3. Press on the option that corresponds to the type of smartphone to use.
A procedure for configuring the network to use when in mobility is started.
4. Follow the instructions that appear on screen.

9.7.3 Check status of online services

This function allows running tests on the online services.

Proceed as follows:

1. Press: **Check status of online services**

The function's main screen is displayed.

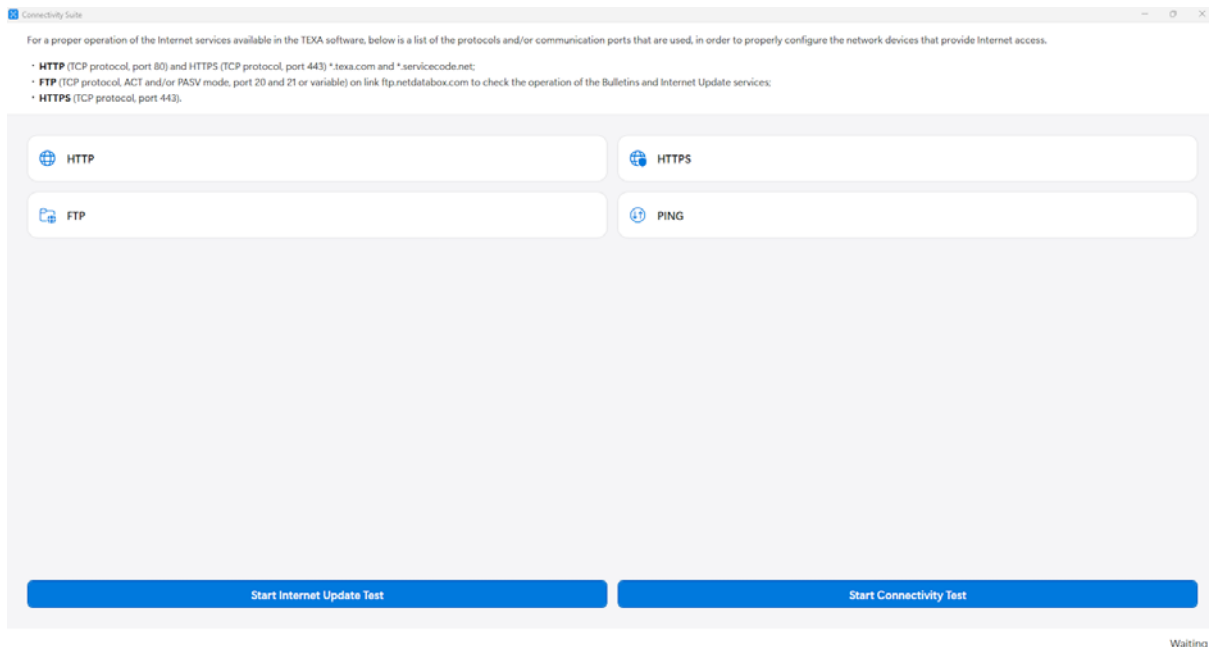

2. Press on the icon related to the test you wish to run.

The test is started and the result is displayed automatically.

10 AI GLOBAL SEARCH



This function allows launching the search powered by AI.

The function allows querying in advance TEXA's databases to locate all the information related to a certain vehicle.

The software allows carrying out free searches, that is not linked to a specific selection.

Alternatively, the function can be launched during or at the end of the vehicle selection procedure.

NOTICE

The concise response generated by the software cannot guarantee nor ensure: the correct understanding of the request formulated by the User; the accuracy and completeness of the information provided; the absence of errors or lack of information.

This response does not substitute the sources based on which it was generated, nor the evaluations by the User as vehicle repair expert.

INFORMATION

The function is designed and developed to only manage queries related to problems and repairs in the automotive field.

INFORMATION

In order to use the function you must first access the myTEXA portal

through  .

The displayed chat is linked to the access credentials and HASP key connected to the display unit.

Proceed as follows:

1. Press:

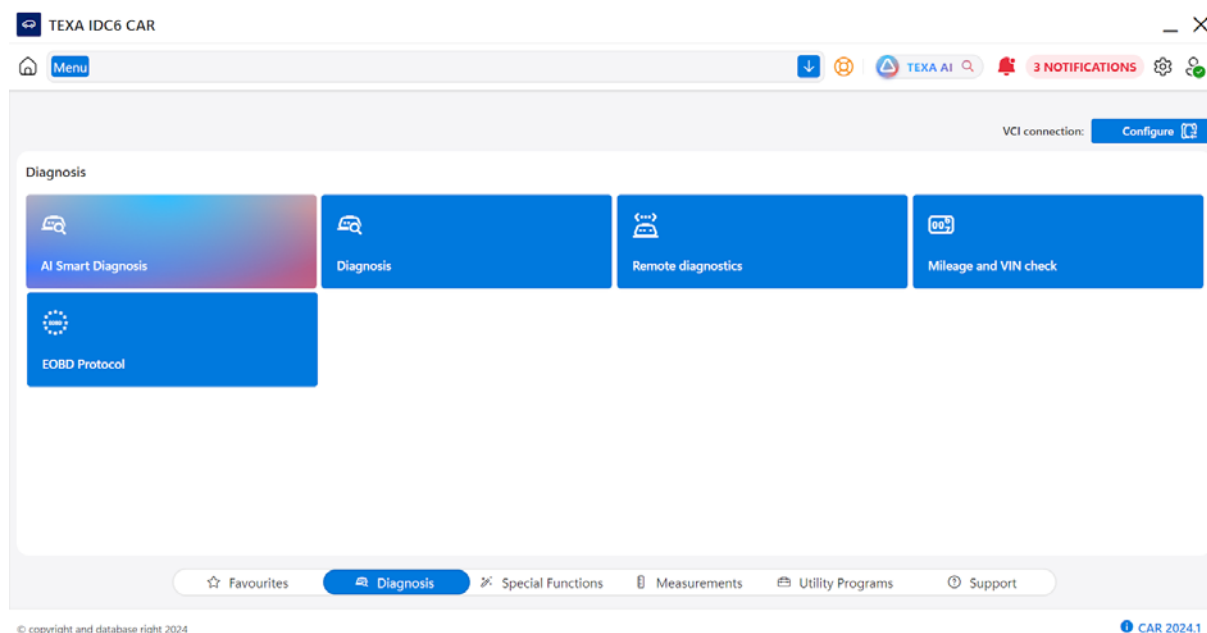

2. Enter the query.

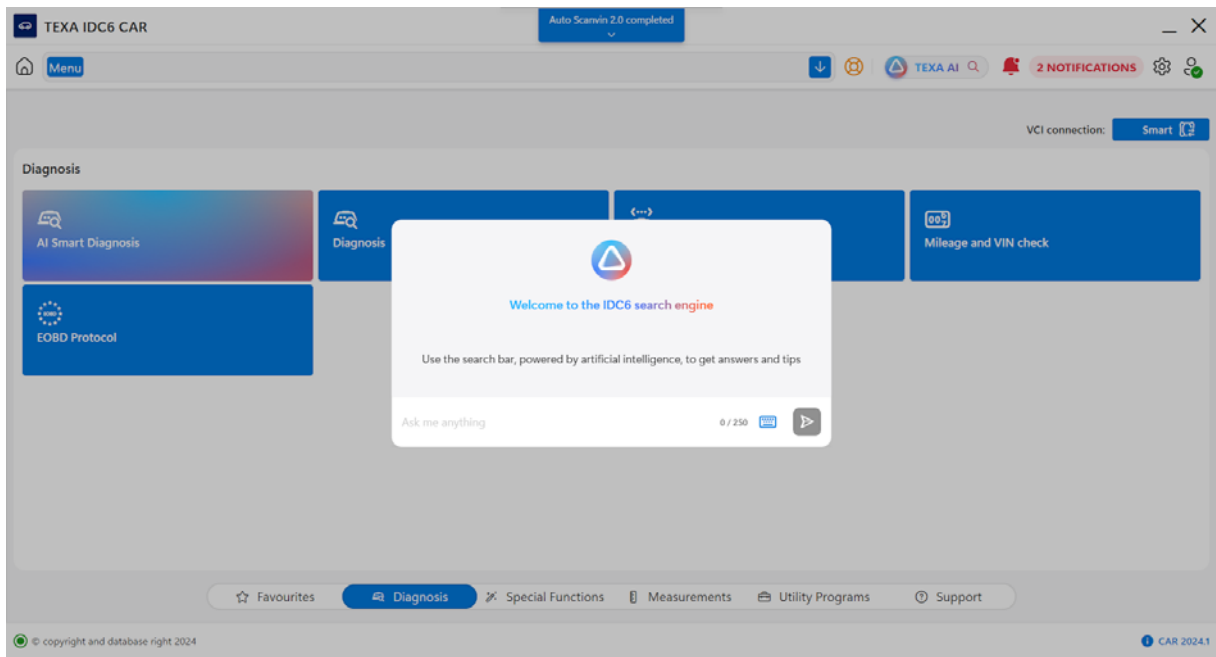

INFORMATION

To optimise the search for a response, you should:

- use a language as discursive as possible;
- enter as much information / as many indications as possible related to the topic of interest;
- submit simple and direct queries.

3. Press:



A conversation related to the topic of the query is started.

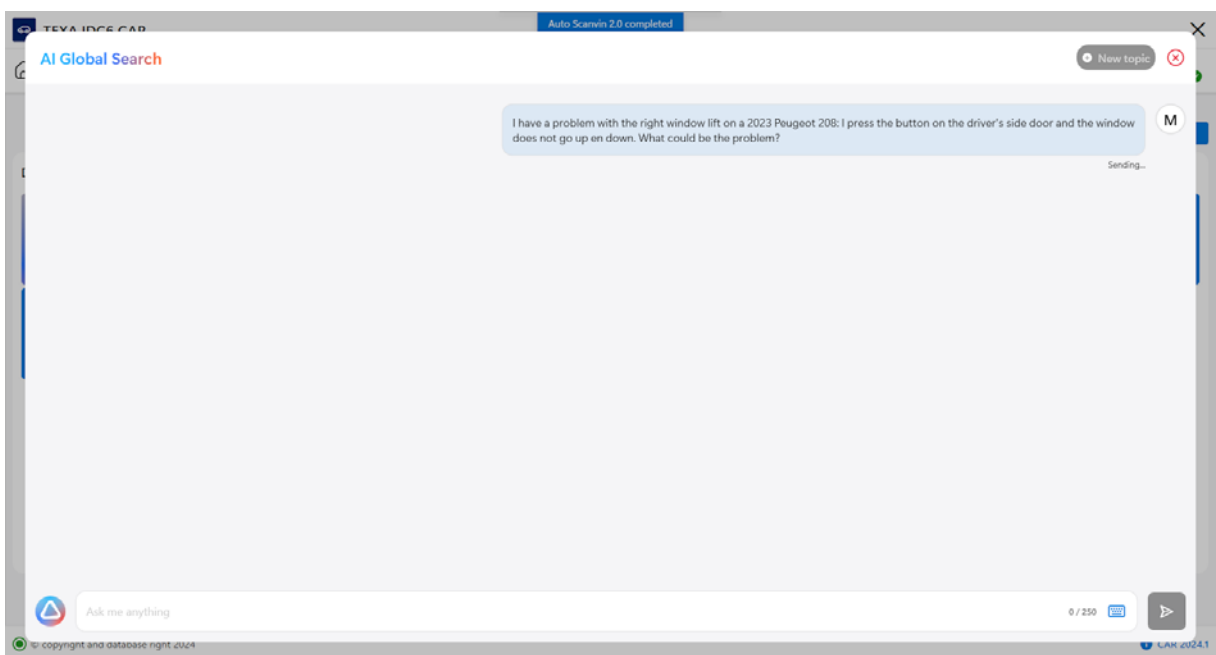

The software provides a response by crossing the information given by the User and the information available in its databases.

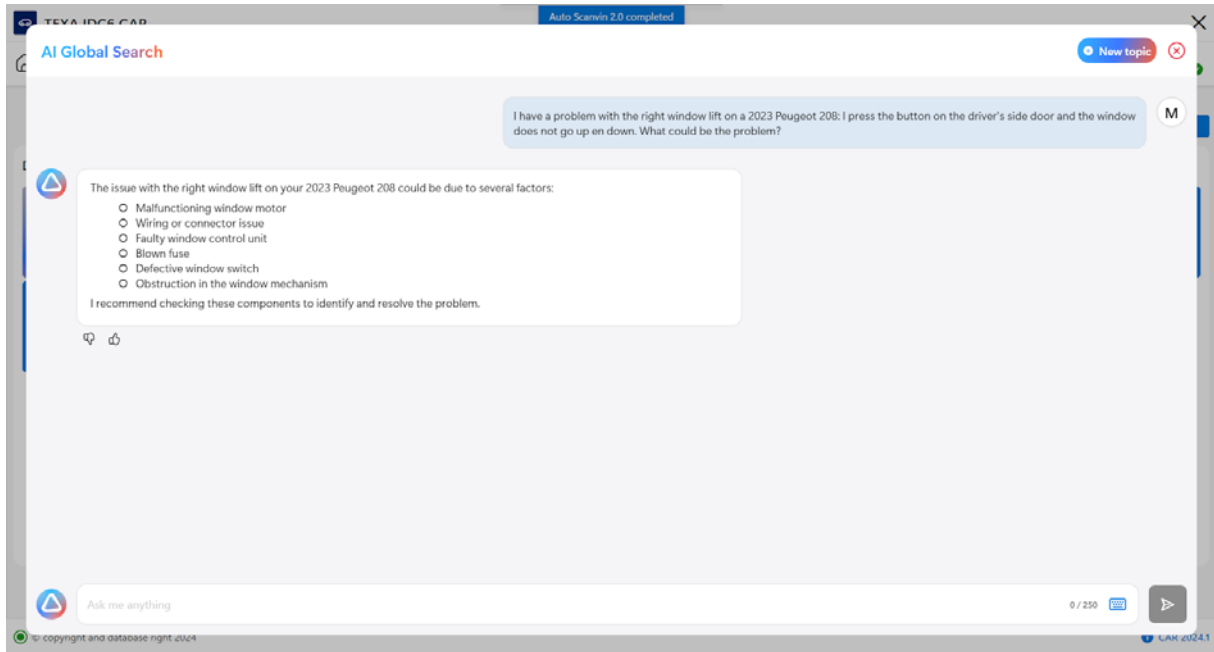

You can explicitly ask for help on the procedure required to solve the problem.

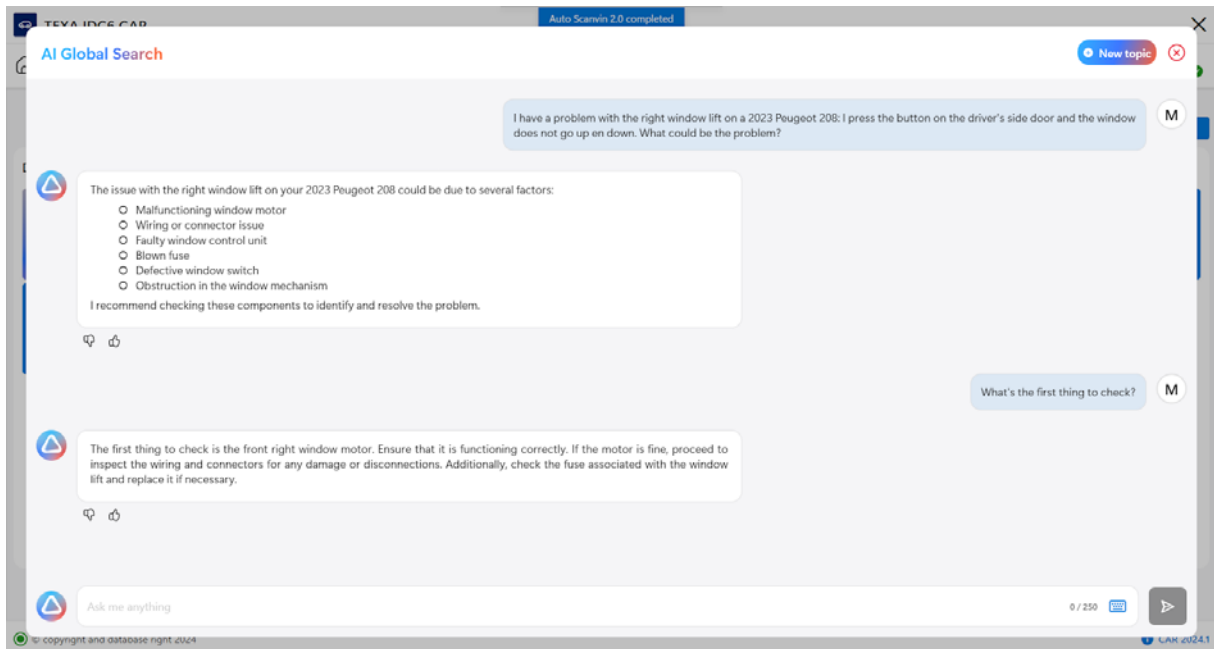

You can also ask if there are specific error codes for the problem found.

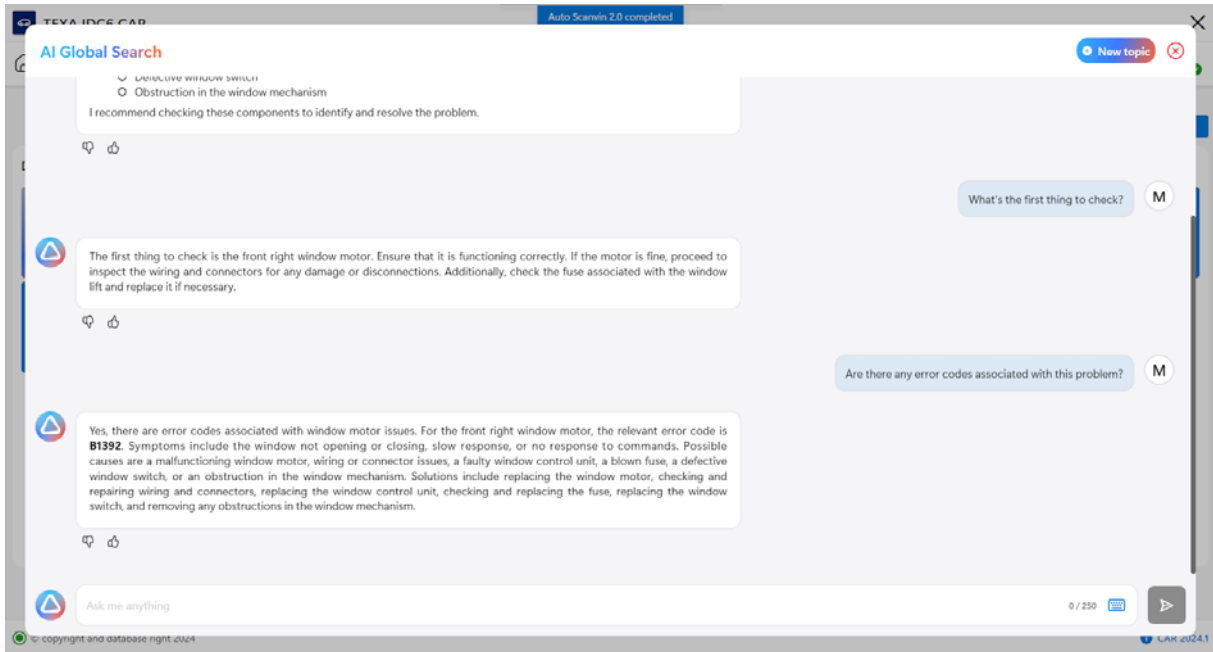

If, instead, information regarding a specific error code is requested, and it is not related to the vehicle indicated previously, the software will require extending the search.

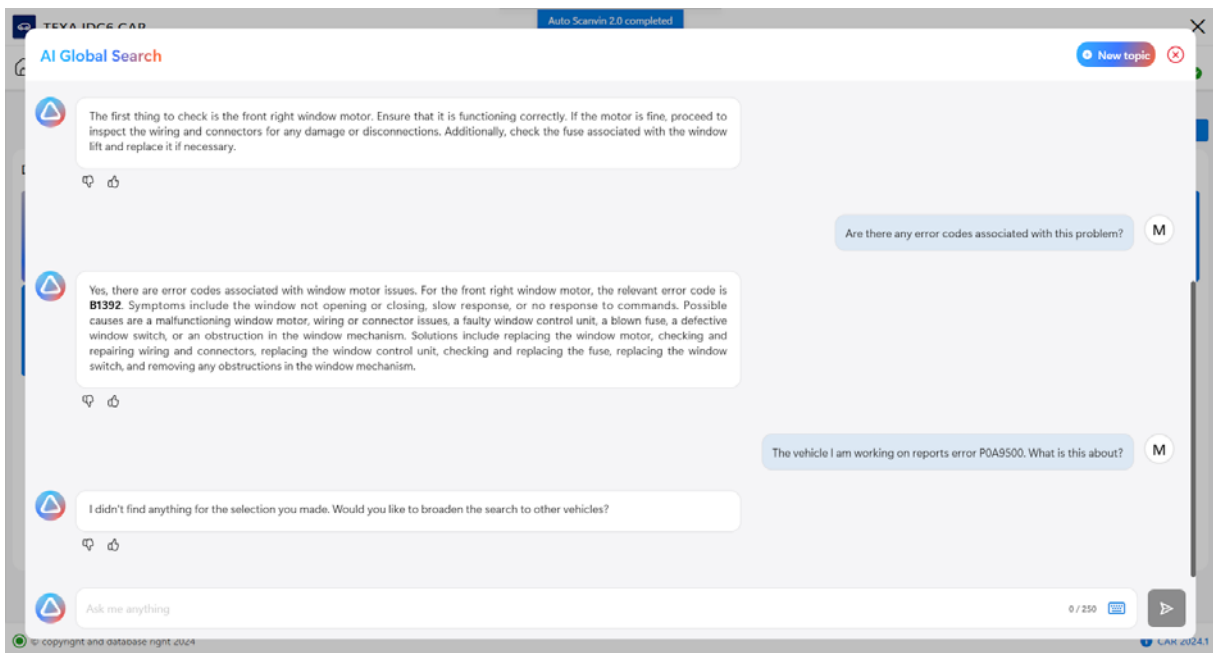

This way the software expands the search field in order to provide the best response possible.

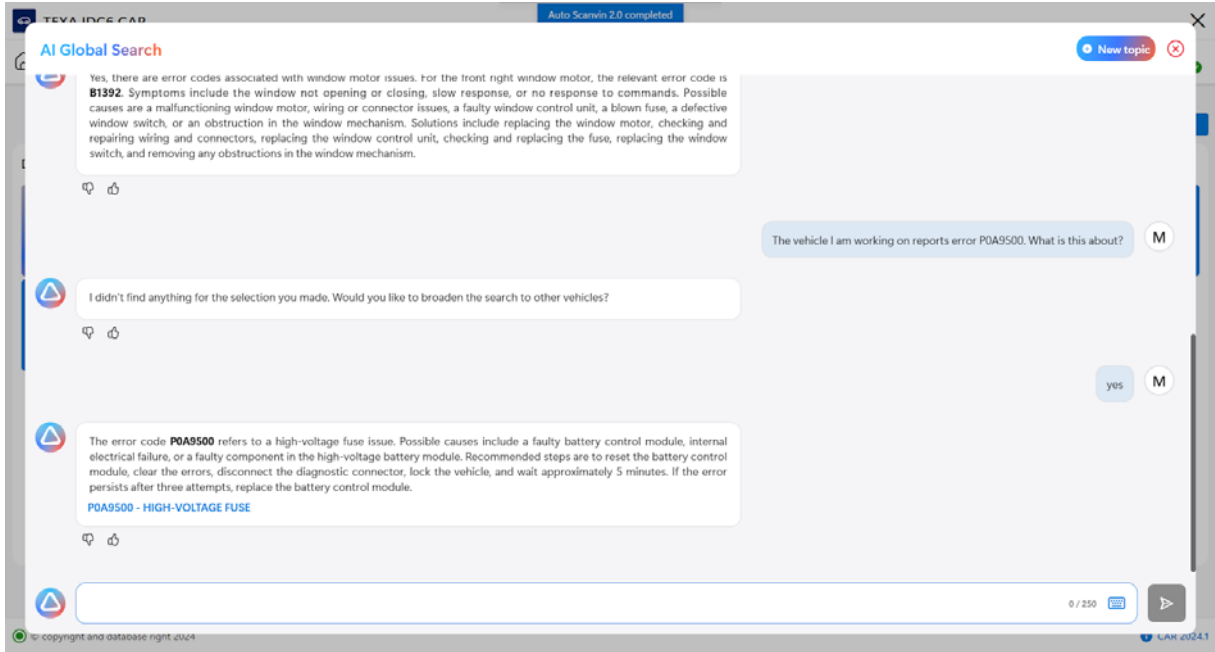

You can access specific contents by pressing on the links in the received response.

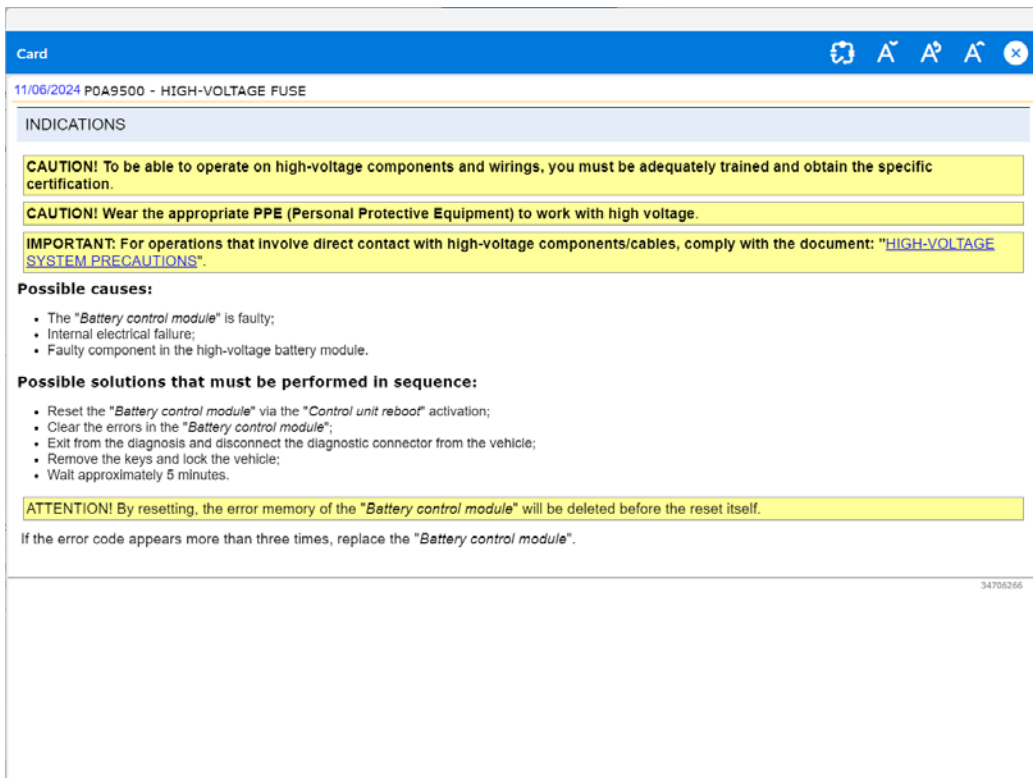

You can launch the function during or at the end of the vehicle selection procedure. In this case the search field is limited to the information available for the selected vehicle. Proceed as follows:

1. Make a selection.

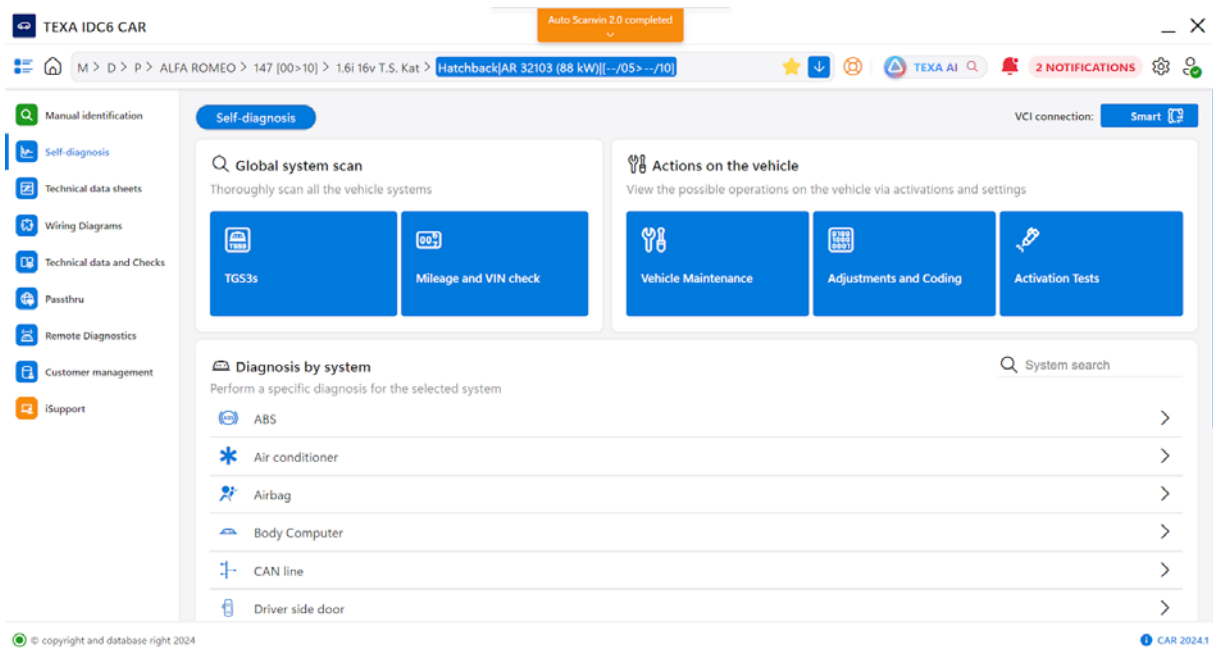

1. Press: 

The software asks if a new topic related to the selection made should be started.

2. Press: **Yes**

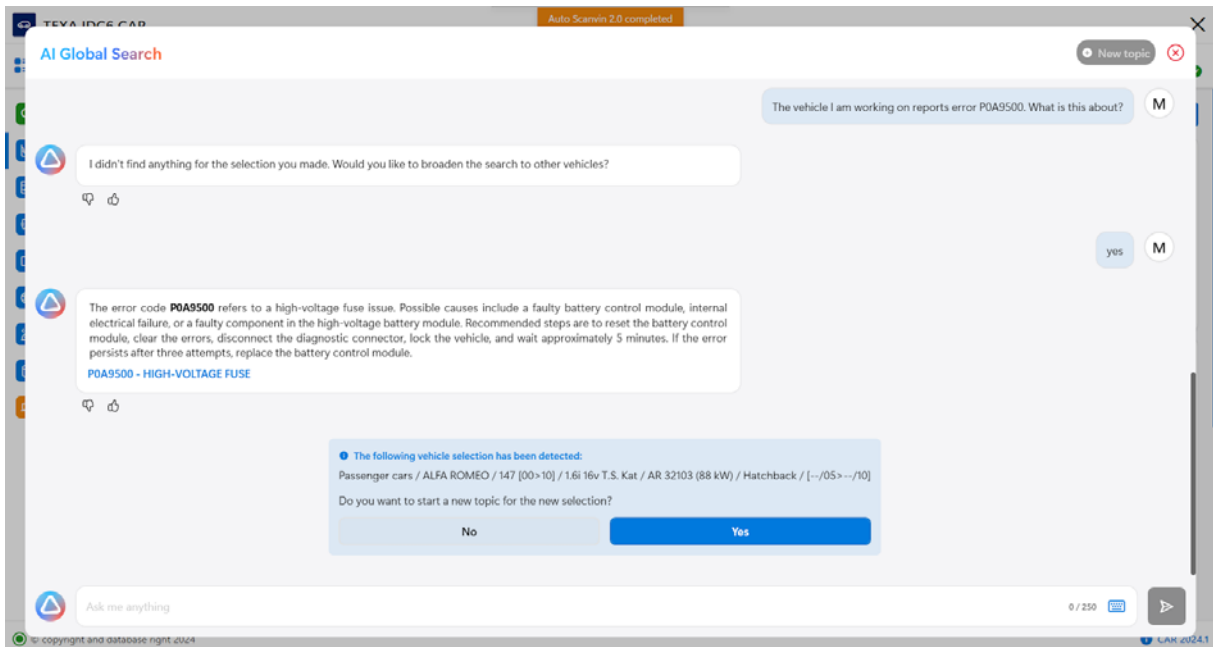

The software indicates the current selection in the top part of the screen.

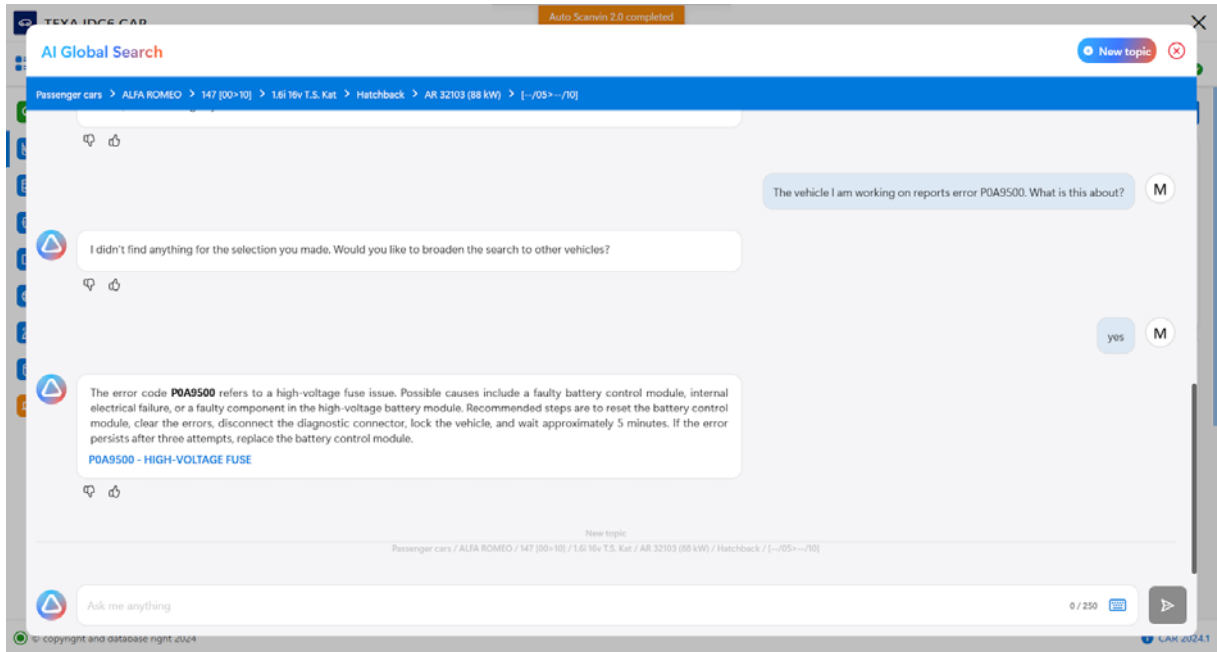

From this moment the search field is limited to the information available for the selected vehicle.

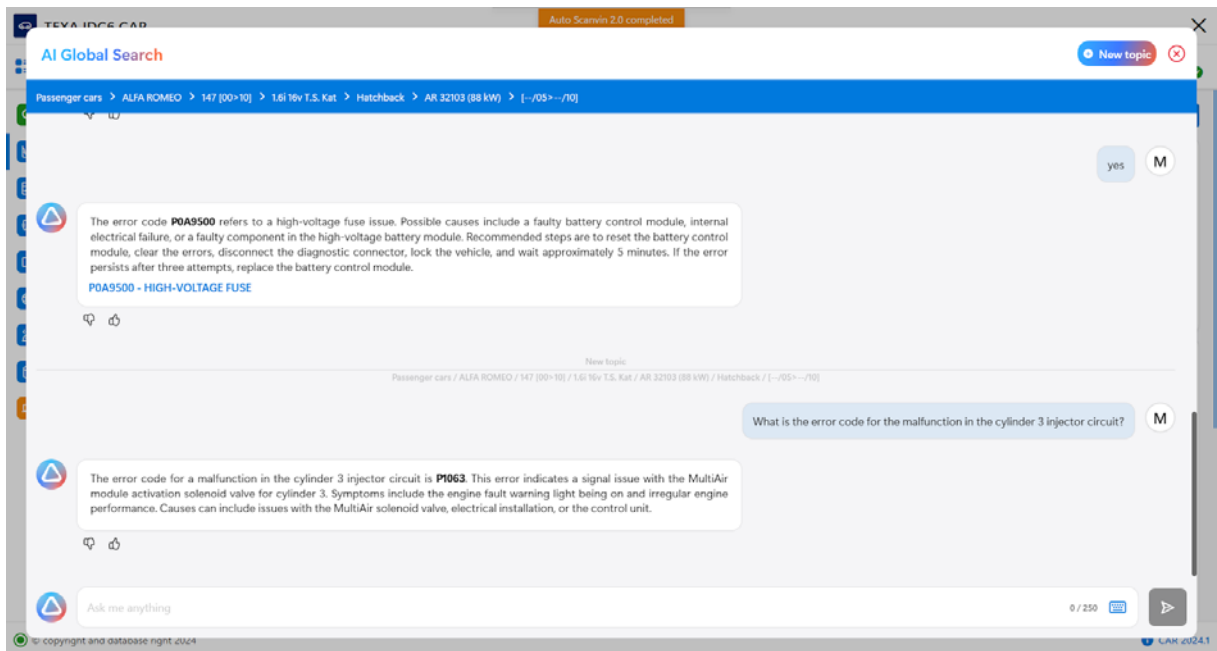

A new topic can be started.

This way the search by the software does not consider the selection made or any previous searches.

Proceed as follows:

1. Press: **New Topic**

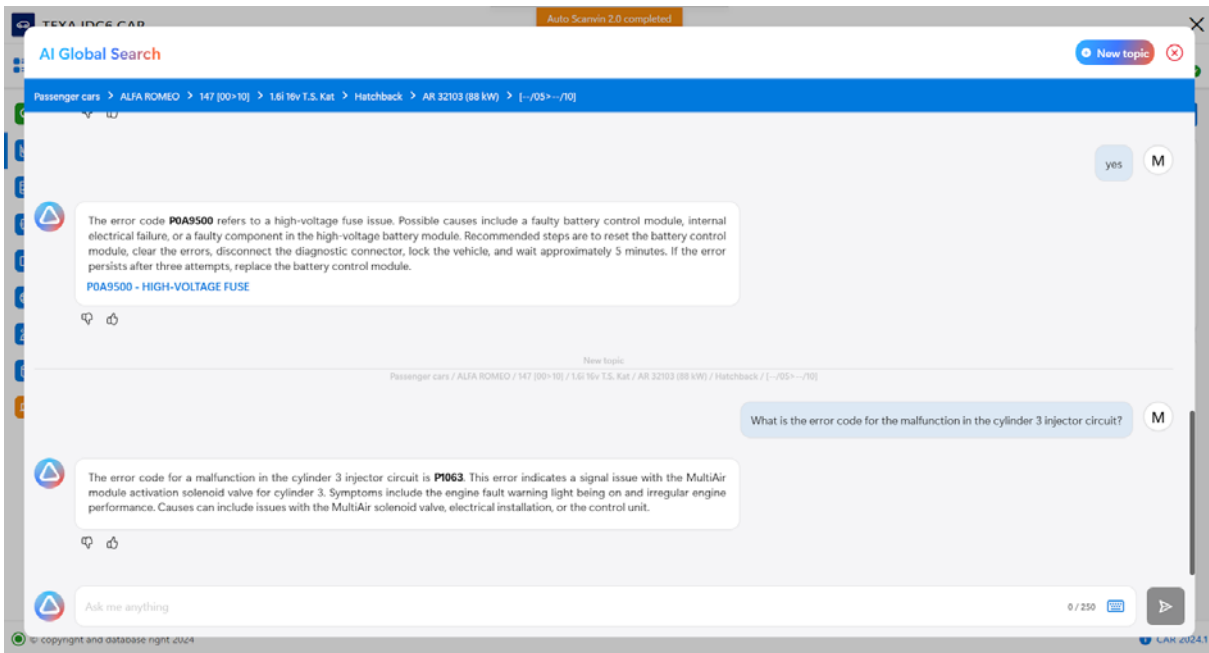

2. Enter the query.

The reference to the previous selection is removed.

the search field for the response is extended to the entire database.

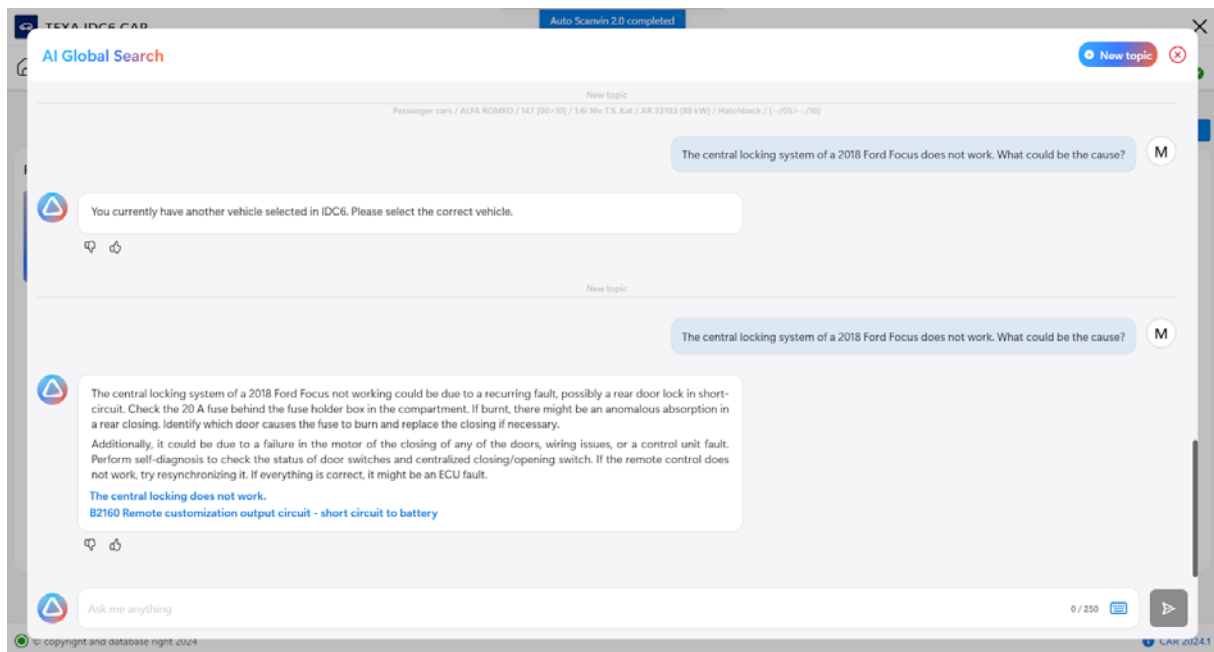

INFORMATION

A new topic can also be started form a free search.

11 FAVOURITES SECTION



This section gathers the functions selected by the operator for a customised **HOME** screen. This section is specific for each environment.

Customised **FAVOURITES** sections can be created for each single environment.

Proceed as follows:

1. Select the **FAVOURITES** section of the desired environment.

Initially the section is empty and can be configured manually by the operator.

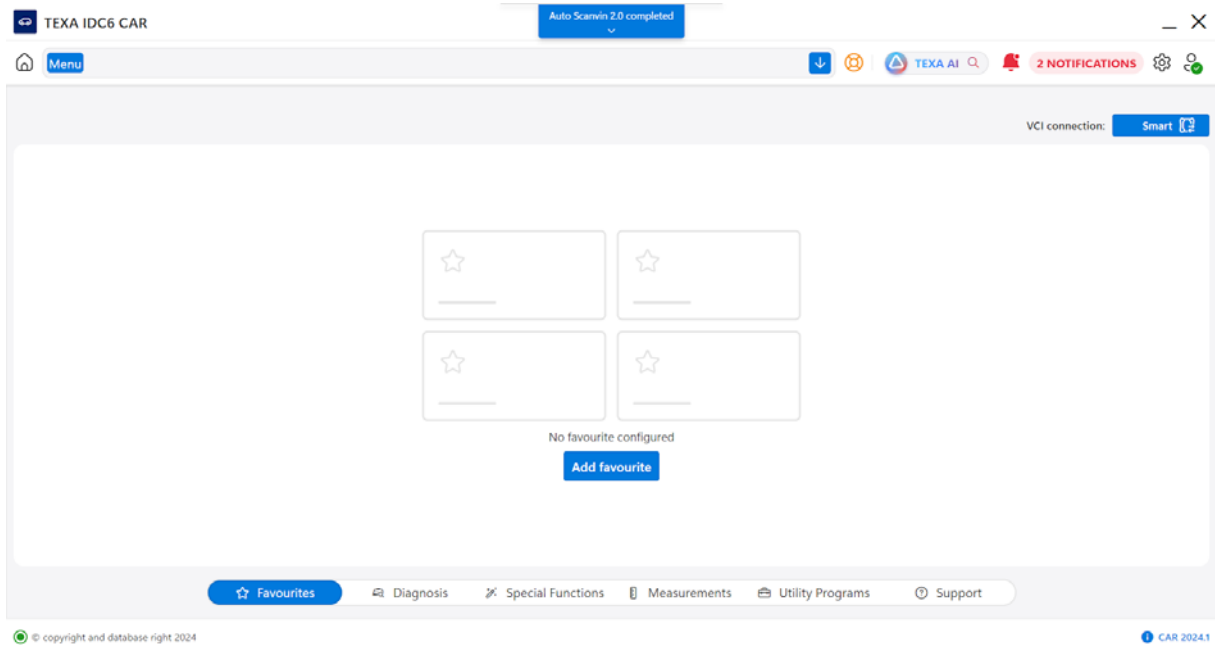

2. Press: **Add favourite**

The list of the selectable functions is displayed.

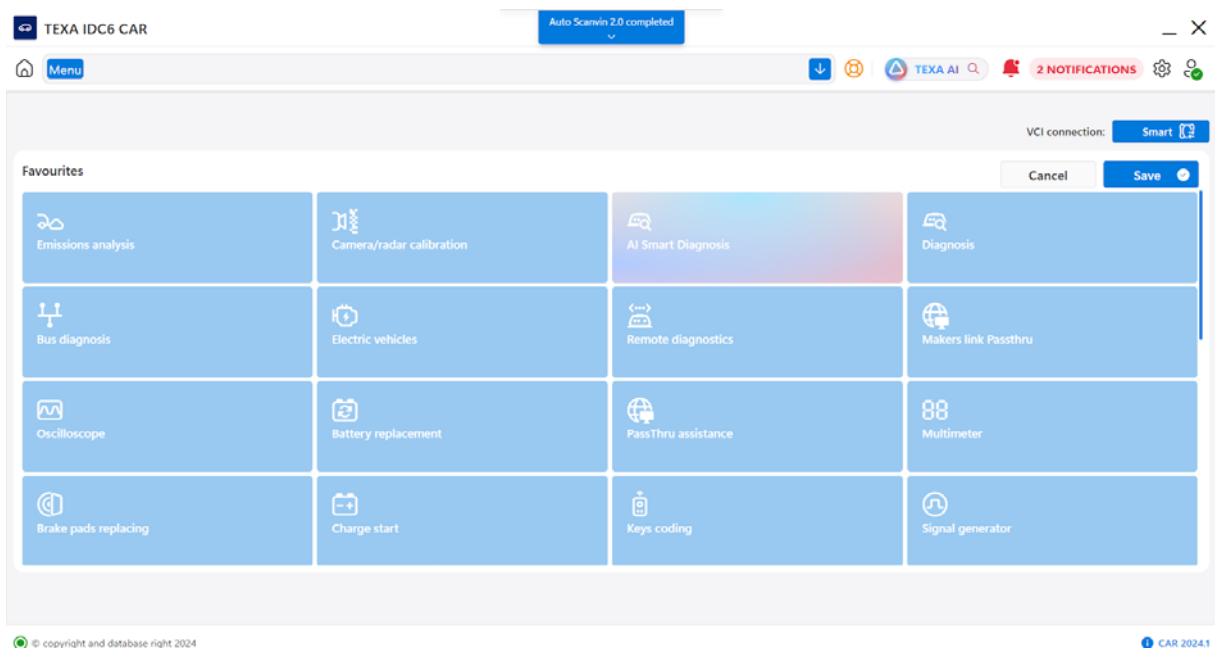

INFORMATION

You can only select functions related to the environment you are in. Functions reserved exclusively to one environment (ex.: TRUCK) cannot be added to the FAVOURITES of another environment (ex.: CAR).

3. Click on the desired function.

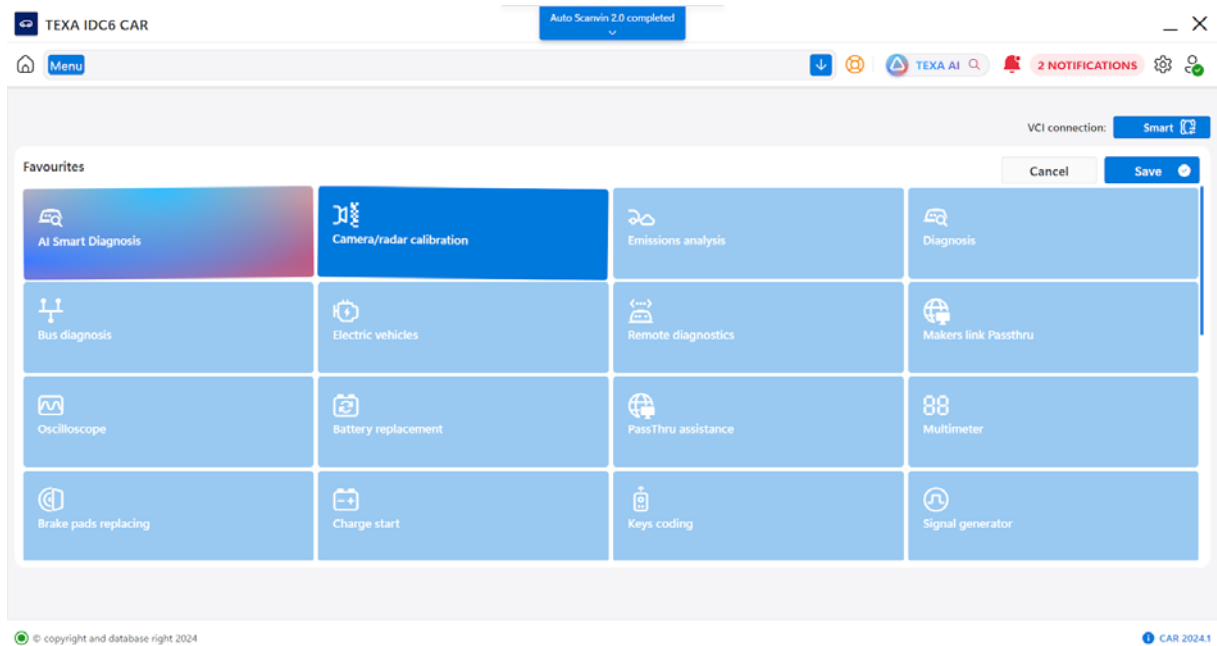

4. Press: **Save**

The **FAVOURITES** section has been configured correctly.

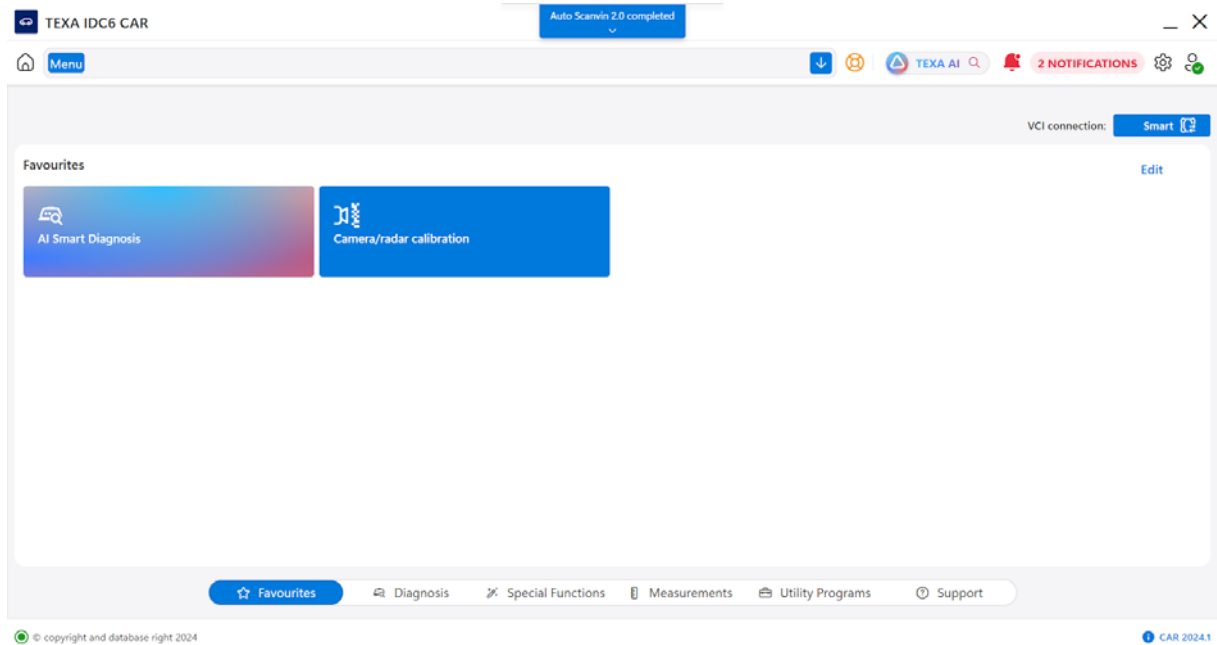

The **FAVOURITES** section is now the environment's new **HOME** screen.

INFORMATION

The configuration of the section can be changed at any time.

Proceed as follows:

- *Press:***Edit**
- *Click on the functions you wish to remove/add.*
- *Press:***Save**





12 DIAGNOSIS SECTION

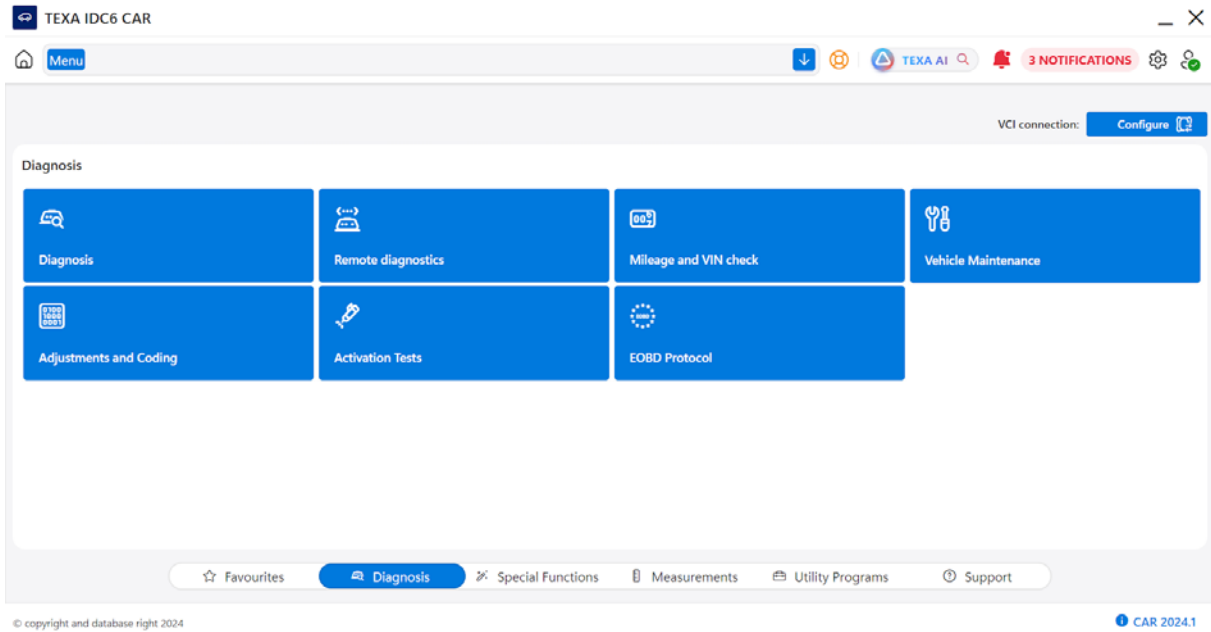

This section gathers the diagnostic functions.



Icon	Name	Description
	AI Smart Diagnosis	It allows using the potentialities of artificial intelligence throughout all the diagnostic phases, from the automatic vehicle selection to the solution of the malfunction.
	Diagnosis	It allows identifying or manually selecting the vehicle on which diagnostic activities should be performed.
	Remote diagnosis	It allows launching the remote diagnosis functions.
	Mileage and VIN check	It allows reading the mileage values and/or the VIN (Vehicle Identification Number) stored in the vehicle control units.
	Vehicle maintenance	It allows accessing the ACTIVATIONS and SETTINGS functions for the specific component selected.
	Adjustments and codings	It allows accessing the SETTINGS function for the specific component selected.
	Device check	It allows accessing the ACTIVATIONS function for the specific component selected.
	EOBD protocol	It allows carrying out a diagnosis targeted at the EOBD parameters.
	Maintenance service	It allows quickly accessing all the functions relating to the vehicle maintenance.
	HD standard protocol	It allows accessing a basic diagnosis that uses the standard protocols for the vehicles of the TRUCK environment.

	OBD standard protocol	It allows accessing a basic diagnosis that uses the standard protocols for the vehicles of the LCV / CAR environment.
	Workshop	It allows accessing the page dedicated to TEXA eTRUCK in the TEXA website.
	OHV standard protocol	It allows accessing a basic diagnosis that uses the standard protocols for the vehicles of the OFF-HIGHWAY environment.
	ISOBUS	It allows carrying out a diagnosis based on the ISO 11783 protocol dedicated to the accessories/equipment in the OFF-HIGHWAY environment.

INFORMATION

Some functions may not be available for all the environments or on all the platforms.

13 AI SMART DIAGNOSIS

This function allows using the potentialities of artificial intelligence throughout all the diagnostic phases, from the automatic vehicle selection to the solution of the malfunction.

Proceed as follows:

1. Press: 

INFORMATION

If you do not have a latest-generation VCI, before starting the scan you will be required to select:

- *category*
- *make*

The software will start the automatic identification of the vehicle to which the VCI is connected.

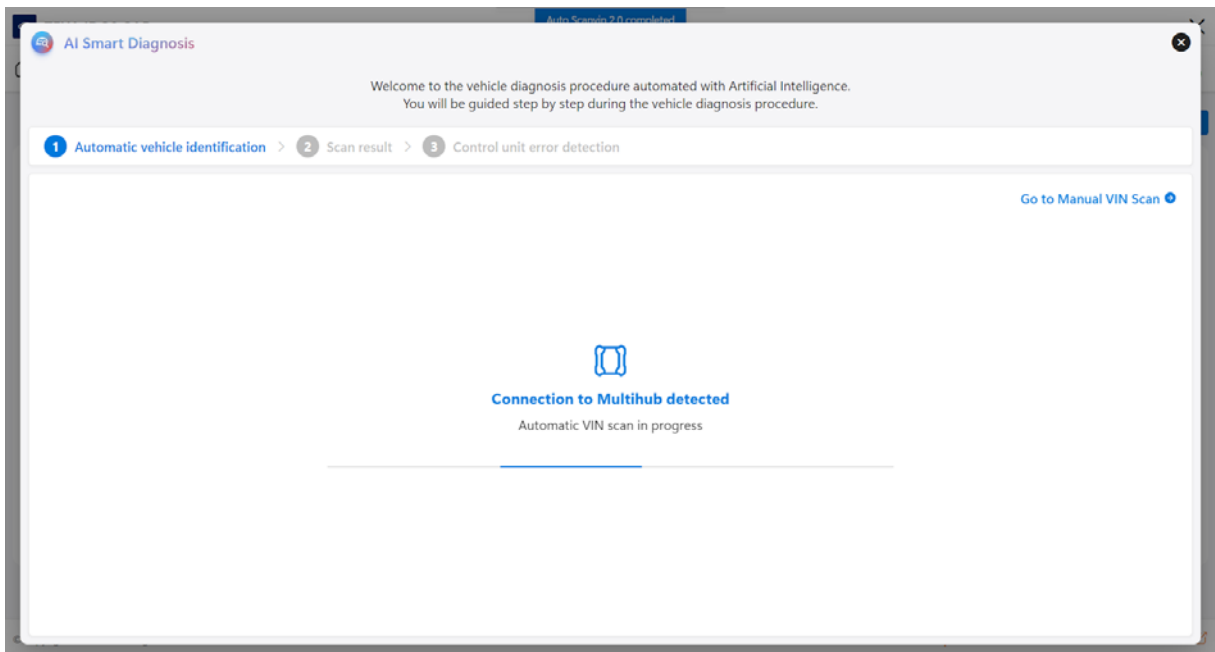

The result of the scan is displayed.

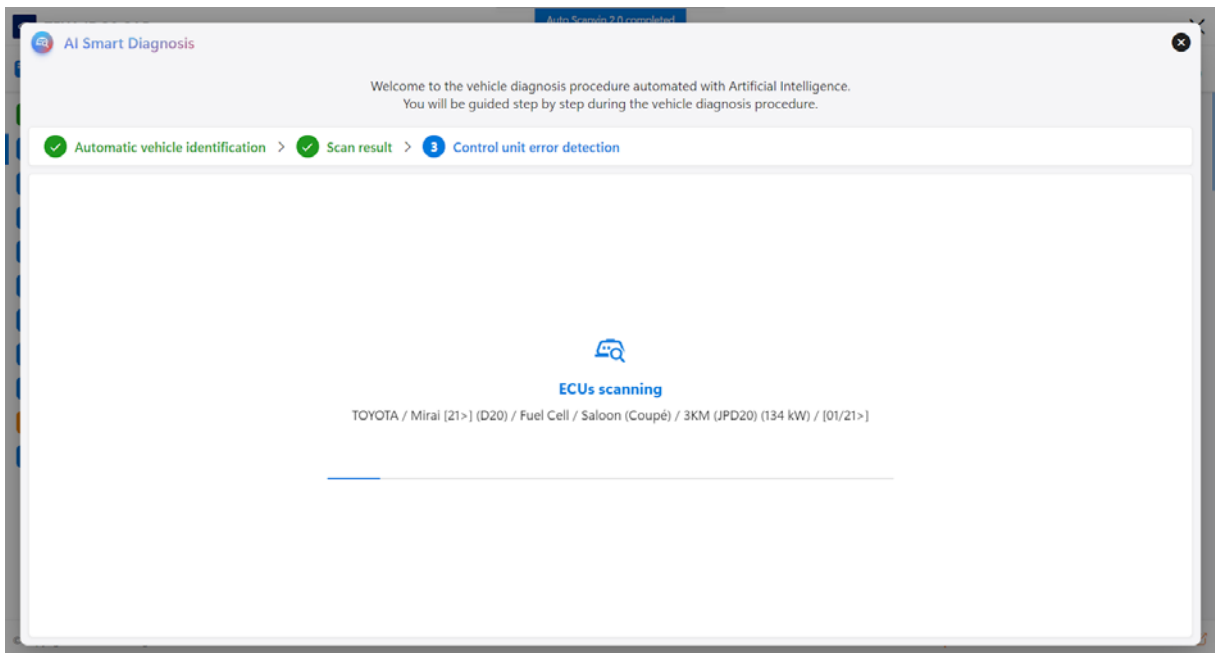

The search for errors in the control units will be launched.

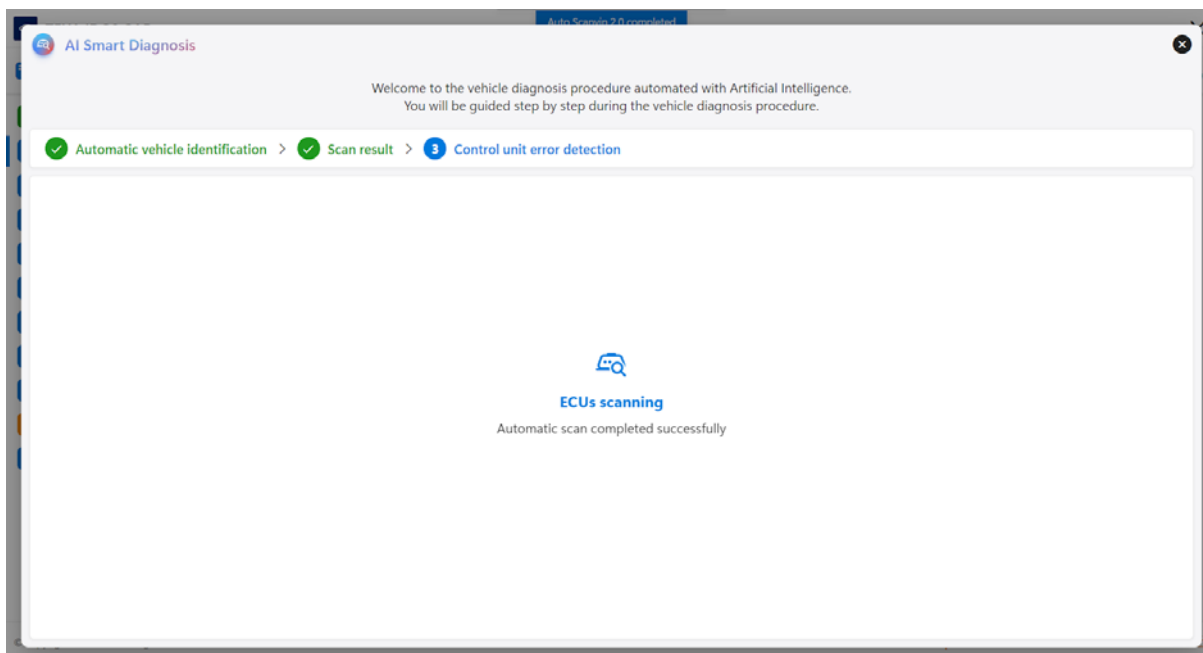

The result of the scan is displayed.



2. Select an error.

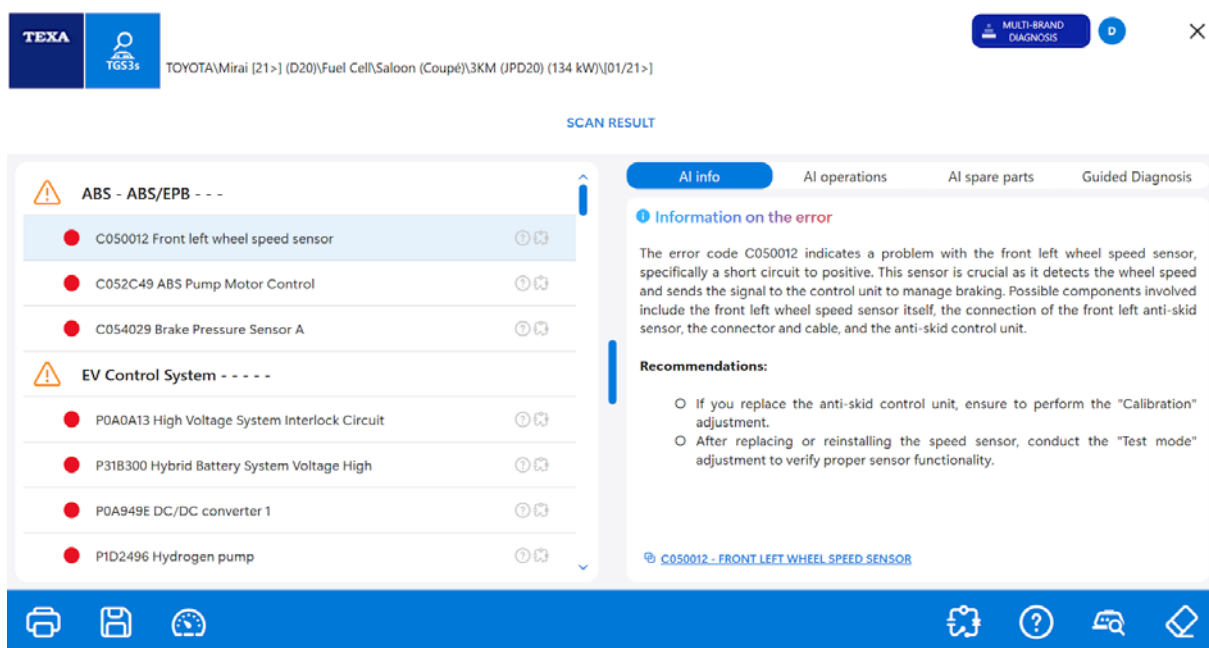



The tabs relating to the AI functions available for the selection performed will be displayed.



INFORMATION

The number and type of tabs may vary based on the selection.

Icon	Name	Description
	Print	It allows you to print a report related to the detected errors.
	Save	It allows recording the detected errors and saving them in the Customer Management archive.

	Dashboard	It allows viewing a graphical representation of the vehicle that is useful for the diagnostic operations.
	Component location	It allows finding the component affected by the error through the Wiring Diagrams function.
	Help	It allows displaying a help screen related to the selected error.
	Diagnosis	It allows starting the diagnosis on the system related to the selected error.
	Delete Errors	It allows deleting the detected errors.

For further information, see the chapter:DIAGNOSIS BY SYSTEM

13.1 AI info

This function provides information generated automatically by AI relating to the selected error.

1. Press:AI info

TEVA TGS3s TOYOTA\Mirai [21->] (D20)\Fuel Cell\Saloon (Coupe)\3KM (JPD20) (134 kW)\[01/21->]

MULTI-BRAND DIAGNOSIS

SCAN RESULT

AI info | AI operations | AI spare parts | Guided Diagnosis

ABS - ABS/EPB - - -

- C050012 Front left wheel speed sensor
- C052C49 ABS Pump Motor Control
- C054029 Brake Pressure Sensor A

EV Control System - - - -

- P0A0A13 High Voltage System Interlock Circuit
- P31B300 Hybrid Battery System Voltage High
- P0A949E DC/DC converter 1
- P1D2496 Hydrogen pump

Information on the error

The error code C050012 indicates a problem with the front left wheel speed sensor, specifically a short circuit to positive. This sensor is crucial as it detects the wheel speed and sends the signal to the control unit to manage braking. Possible components involved include the front left wheel speed sensor itself, the connection of the front left anti-skid sensor, the connector and cable, and the anti-skid control unit.

Recommendations:

- If you replace the anti-skid control unit, ensure to perform the "Calibration" adjustment.
- After replacing or reinstalling the speed sensor, conduct the "Test mode" adjustment to verify proper sensor functionality.

[C050012 - FRONT LEFT WHEEL SPEED SENSOR](#)

INFORMATION

If available, the tab will also include a link to the technical documents specific for the selected error.

13.2 AI operations

This function provides a series of operations recommended to solve the error. The recommended operation is assigned a degree of reliability.

1. Press:AI operations

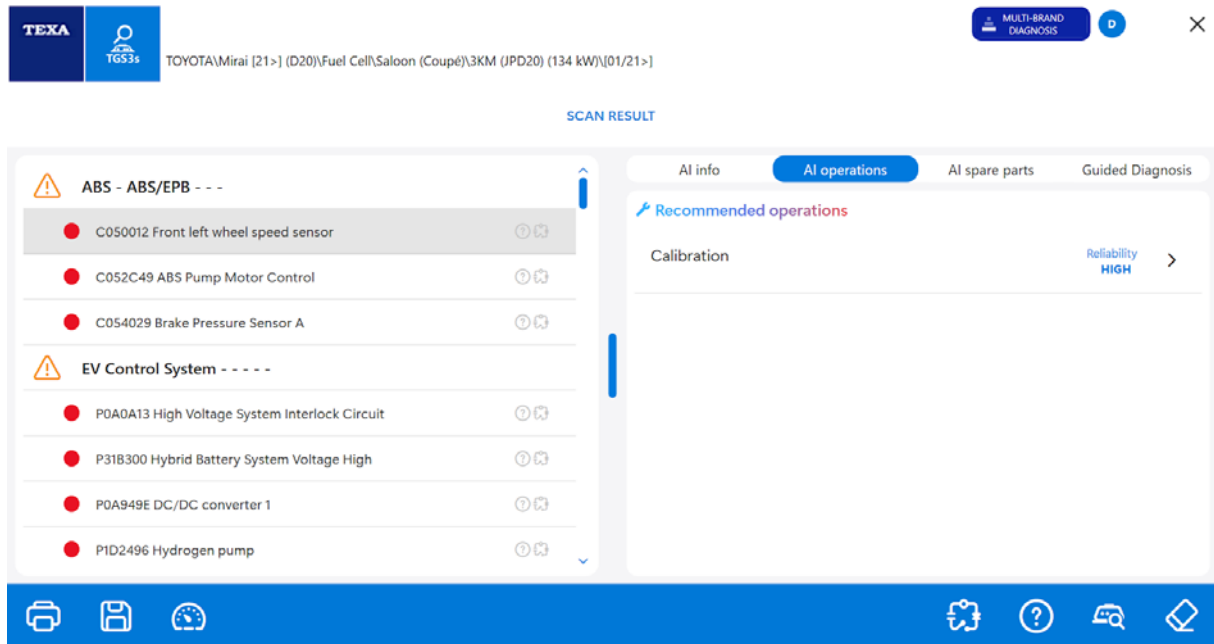

2. Select the desired operation.
3. Follow the instructions that appear on screen.

NOTICE

Even if the reliability degree of a recommended operation is classified as "HIGH", it is impossible to guarantee that carrying out the recommended operation will solve the related error completely.

13.3 AI spare parts

This function lists the possible spare parts required to solve the detected fault.

1. Press:AI spare parts

The list of recommended spare parts is displayed.

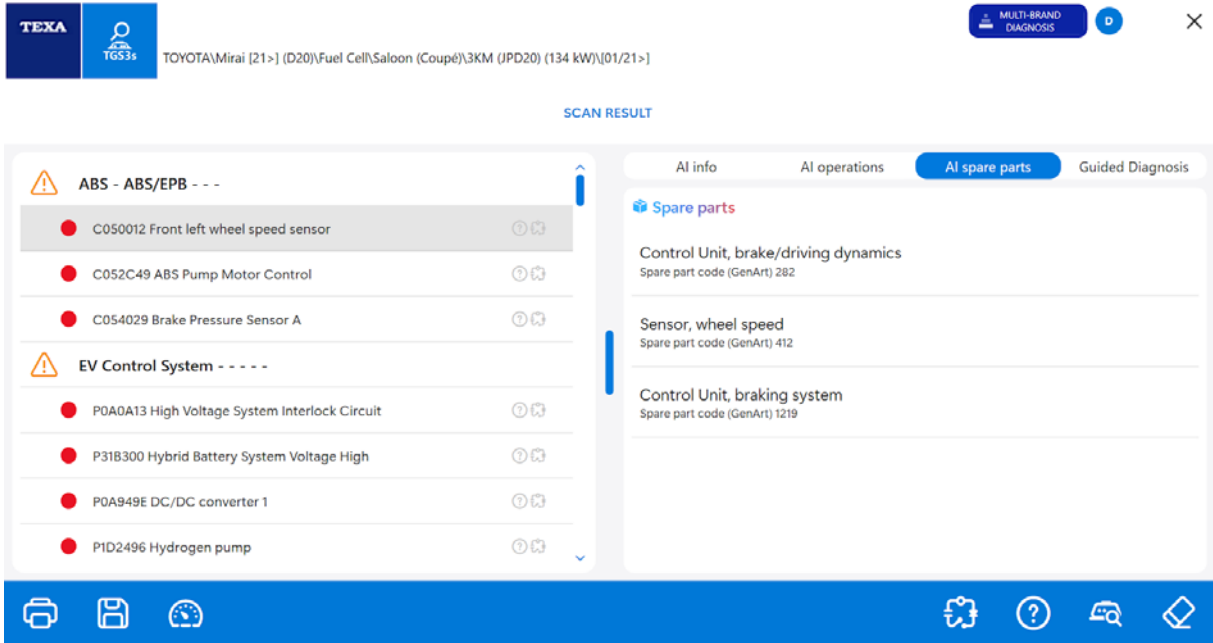

13.4 Guided Diagnosis

This tab starts the GUIDED DIAGNOSIS function automatically.

1. Press: **Guided Diagnosis**
2. Select the desired error.

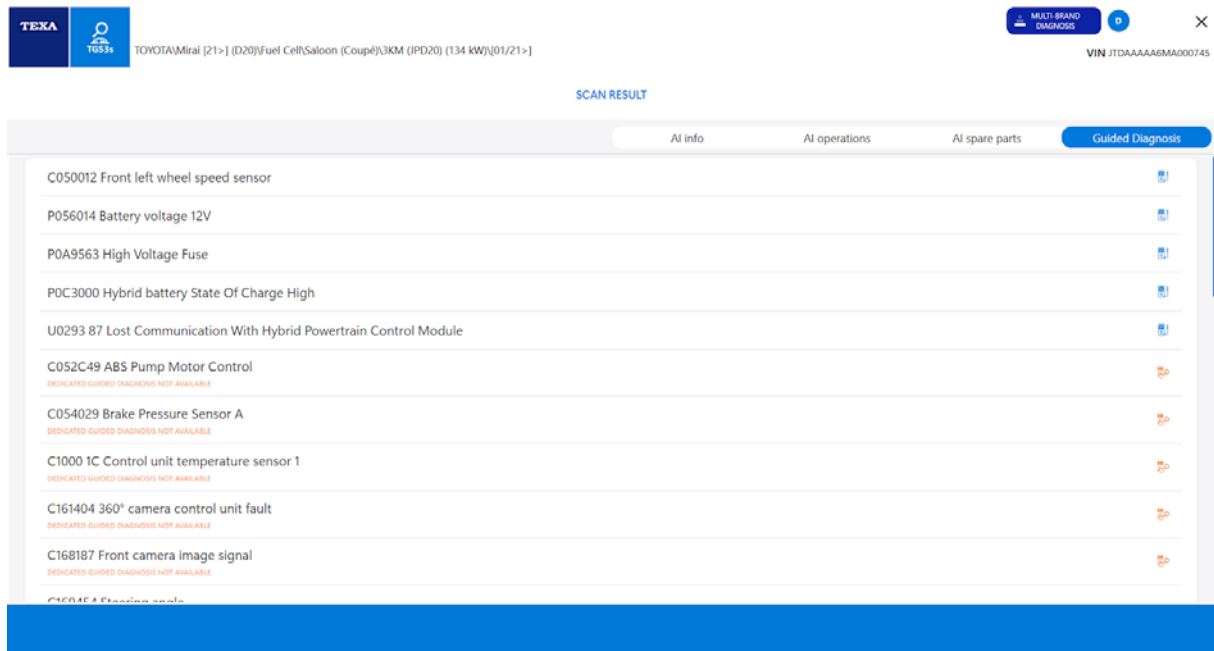

For further information, see the chapter: GUIDED DIAGNOSIS

14 AUTO VIN SCAN 2.0



If you have a latest-generation VCI, the VIN search on the vehicle to which the device is connected is started automatically.

INFORMATION

Some VCIs may not support this function.

For further information consult the manual of the VCI in use.

Proceed as follows:

1. Connect the VCI to the vehicle.
2. Launch the software.

The software indicates that the VIN code scan is complete.

3. Press: **Auto VIN Scan 2.0 completed**

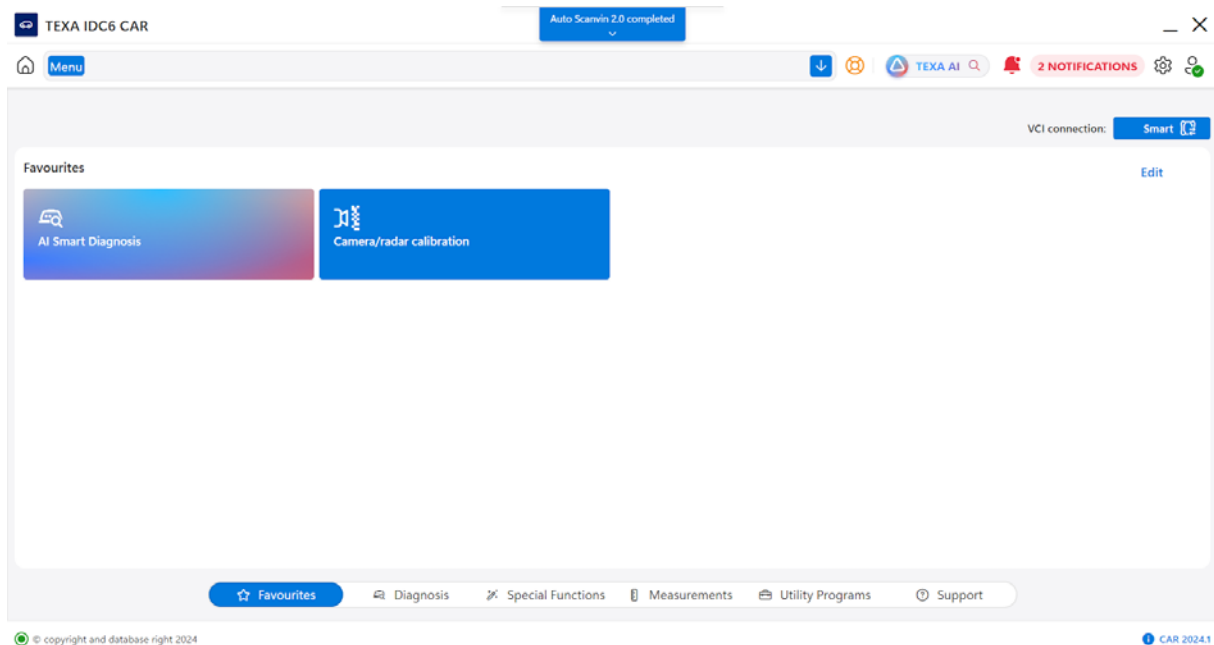

4. Press:Select the vehicle

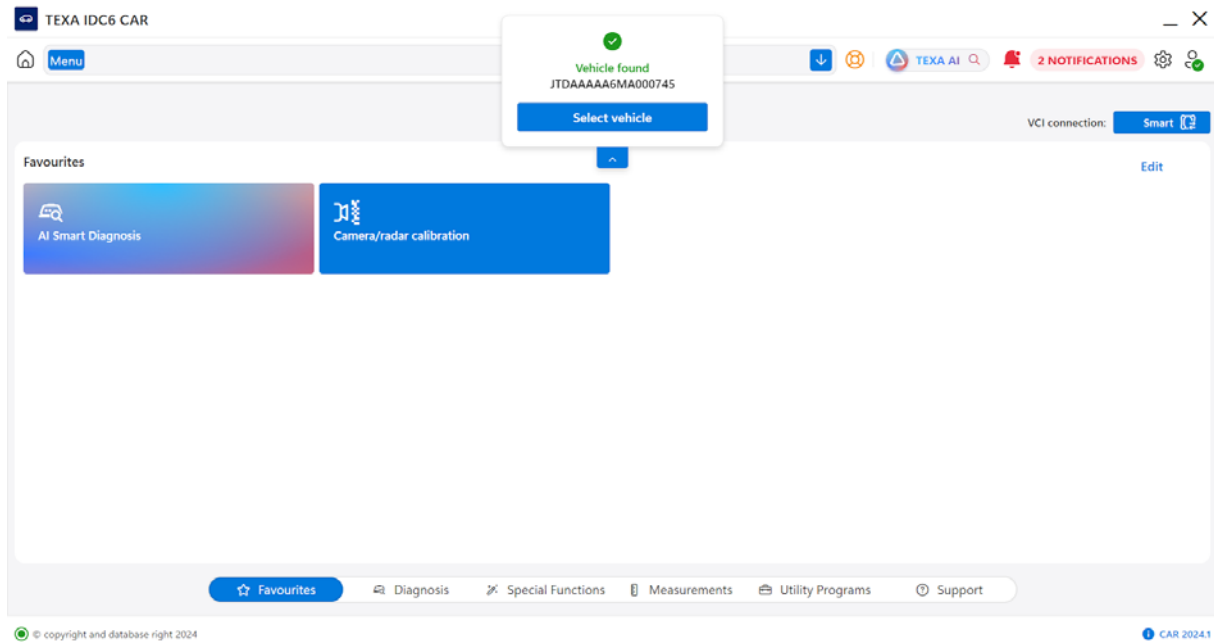

5. Press:Next

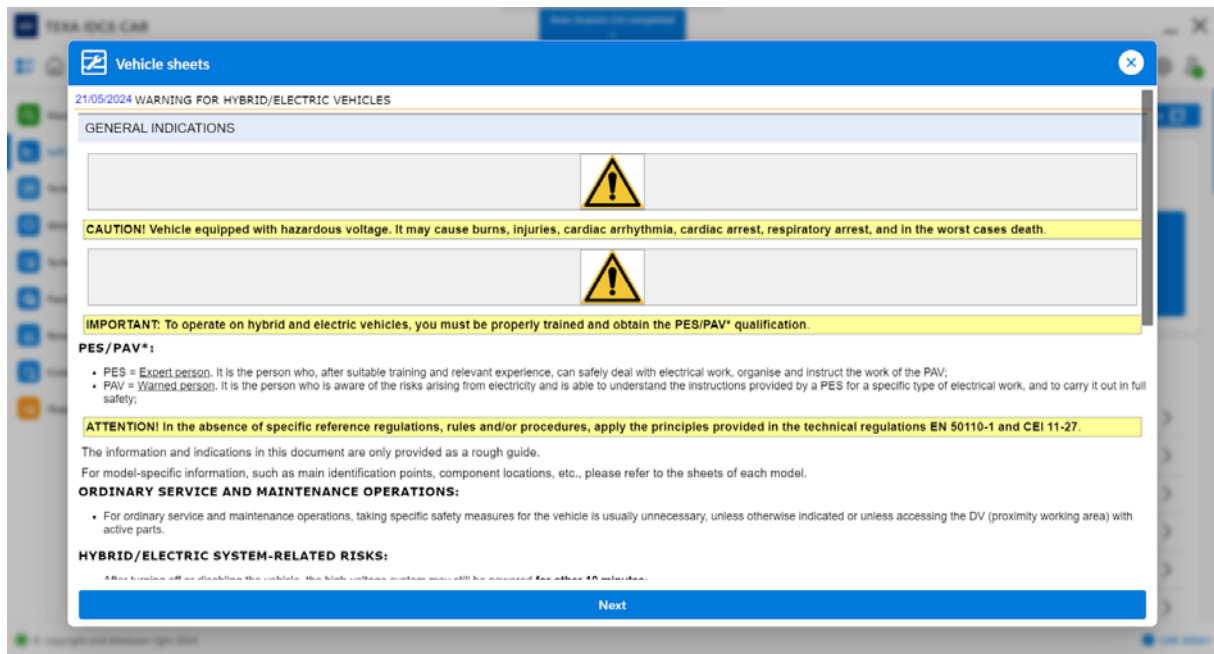

The software automatically selects the vehicle to which the VCI is connected.

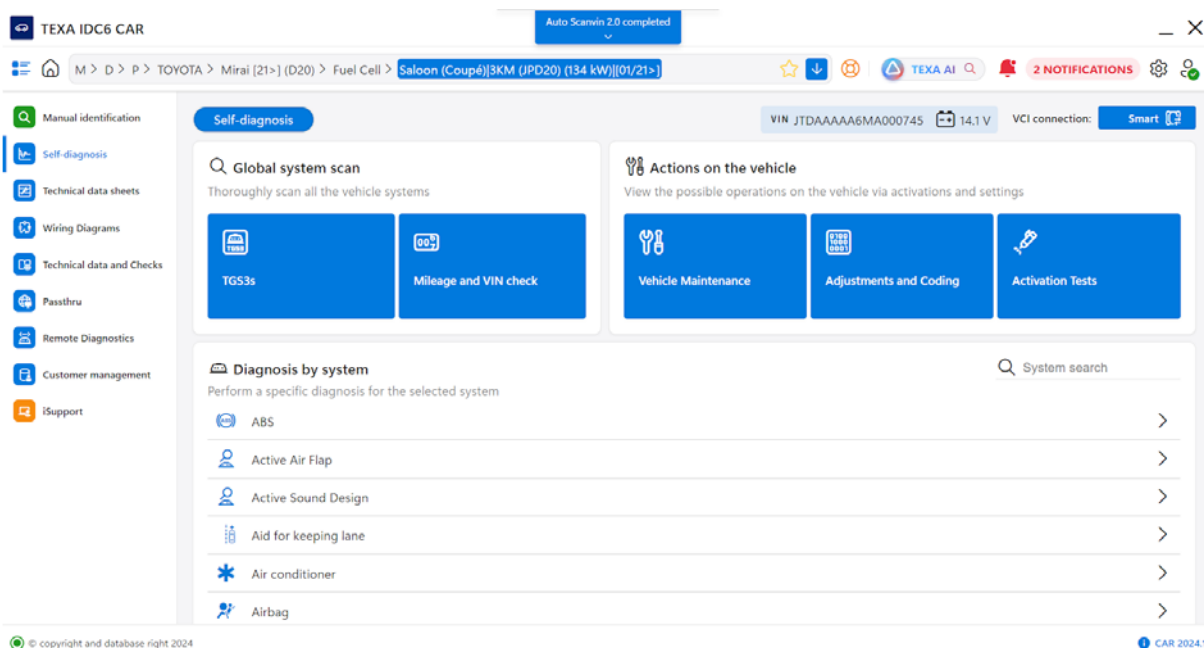

15 SCAN VIN 2.0





This function allows you to automatically identify the vehicle the diagnostic device is connected to.

The function uses the device to scan the control units and retrieve the vehicle's VIN.

Proceed as follows:

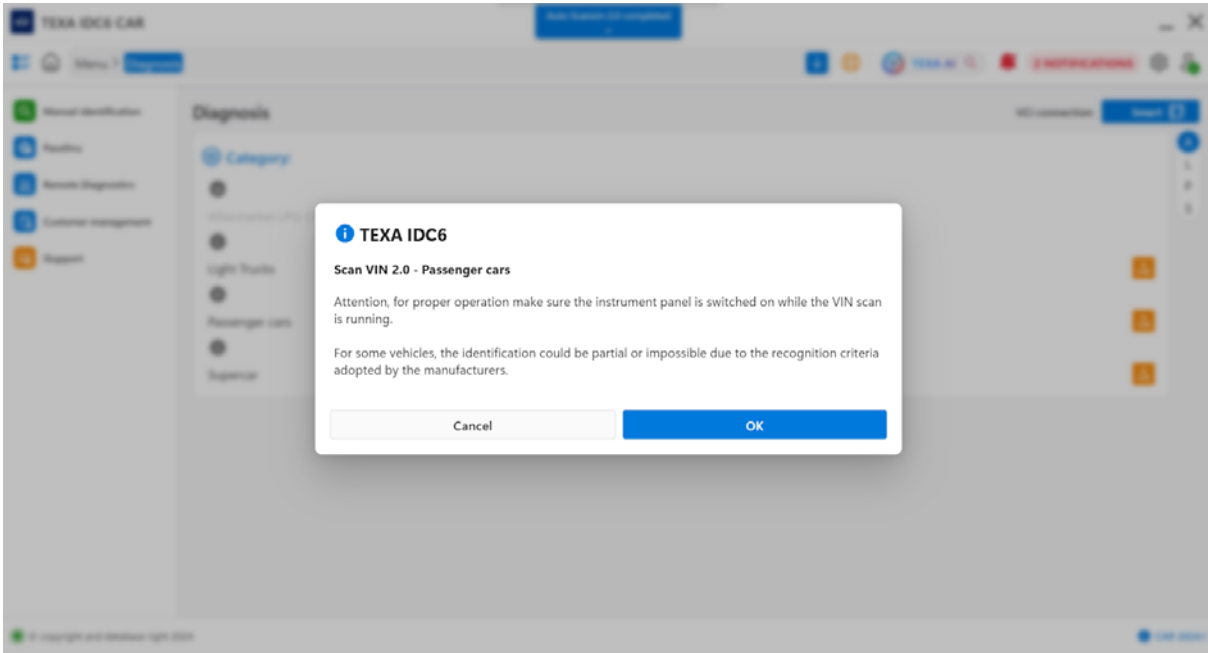
1. Press: 



Icon	Name	Description
	Help	It allows you to view a help screen regarding the automatic VIN identification.

INFORMATION

If the vehicle cannot be identified univocally, the software suggests a list of possible vehicles to select from.

Furthermore, it uses the engine code to filter the available results and make the identification easier.

The engine code can be returned automatically by the control unit or entered manually in a specific text field.

2. Enter the engine code in the specific field.
3. Press: **SEARCH**
4. Select the desired vehicle.

5. Press:Confirm

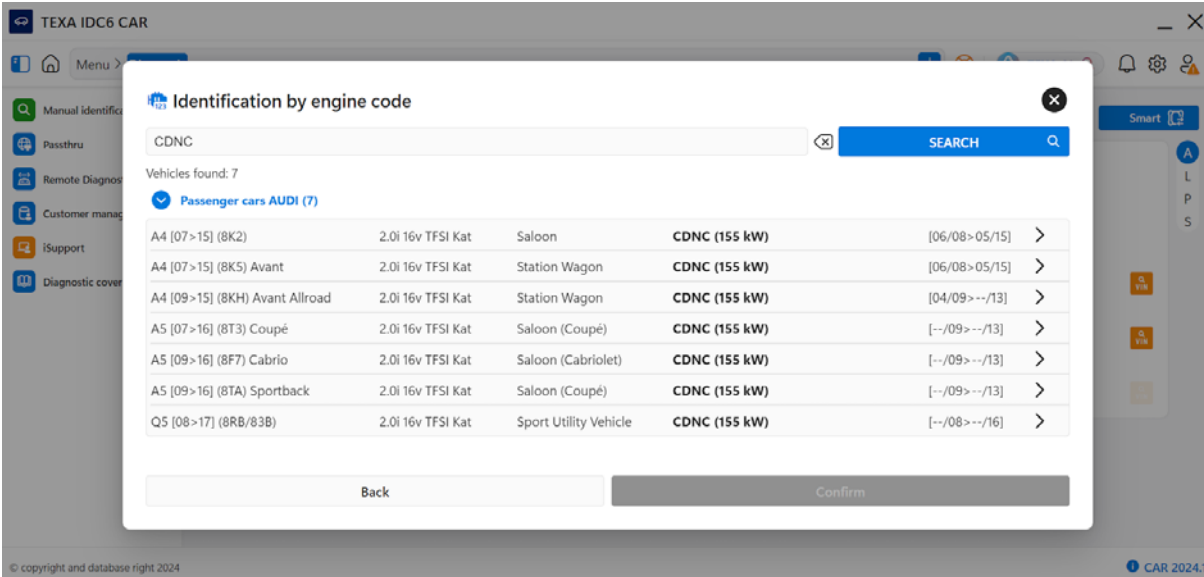

The screenshot shows a software interface for vehicle identification. A search box contains the engine code "CDNC" and a "SEARCH" button. Below the search box, it indicates "Vehicles found: 7" and a filter for "Passenger cars AUDI (7)". A table lists the following vehicles:

Model	Engine	Body Style	Power	Year Range	Action
A4 [07>15] (8K2)	2.0i 16v TFSI Kat	Saloon	CDNC (155 kW)	[06/08>05/15]	>
A4 [07>15] (8K5) Avant	2.0i 16v TFSI Kat	Station Wagon	CDNC (155 kW)	[06/08>05/15]	>
A4 [09>15] (8KH) Avant Allroad	2.0i 16v TFSI Kat	Station Wagon	CDNC (155 kW)	[04/09>--/13]	>
A5 [07>16] (8T3) Coupé	2.0i 16v TFSI Kat	Saloon (Coupé)	CDNC (155 kW)	[--/09>--/13]	>
A5 [09>16] (8F7) Cabrio	2.0i 16v TFSI Kat	Saloon (Cabriolet)	CDNC (155 kW)	[--/09>--/13]	>
A5 [09>16] (8TA) Sportback	2.0i 16v TFSI Kat	Saloon (Coupé)	CDNC (155 kW)	[--/09>--/13]	>
Q5 [08>17] (8RB/83B)	2.0i 16v TFSI Kat	Sport Utility Vehicle	CDNC (155 kW)	[--/08>--/16]	>

At the bottom of the window, there are "Back" and "Confirm" buttons. The "Confirm" button is highlighted in grey, indicating it is the selected action.

The selection has been carried out.

16 MANUAL IDENTIFICATION

This function allows selecting a vehicle using the following search keys:

- *VIN*;
- *engine code*;
- *licence plate number stored in the **Customer Management** archive.*

Proceed as follows:

1. Press: 
2. Select the option that best suits the available information to identify the vehicle correctly.

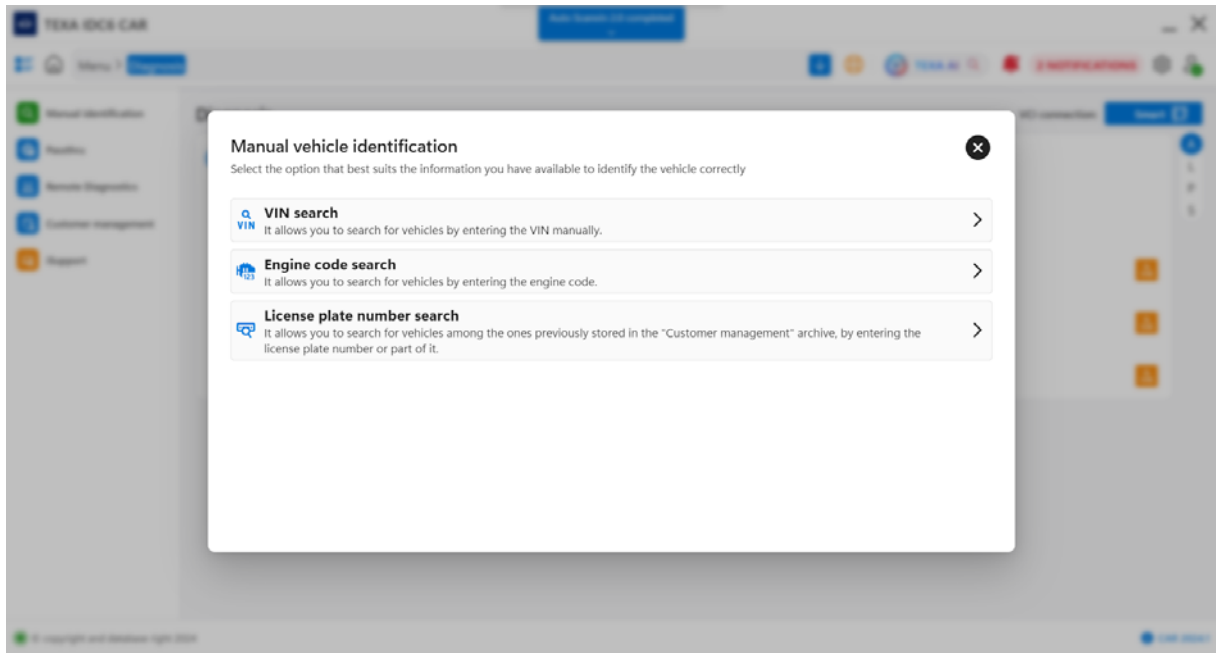

2a. VIN search

It allows searching for vehicles by entering the VIN manually.

Note: You are required to enter at least 10 characters in order to launch the search.

Press:  VIN

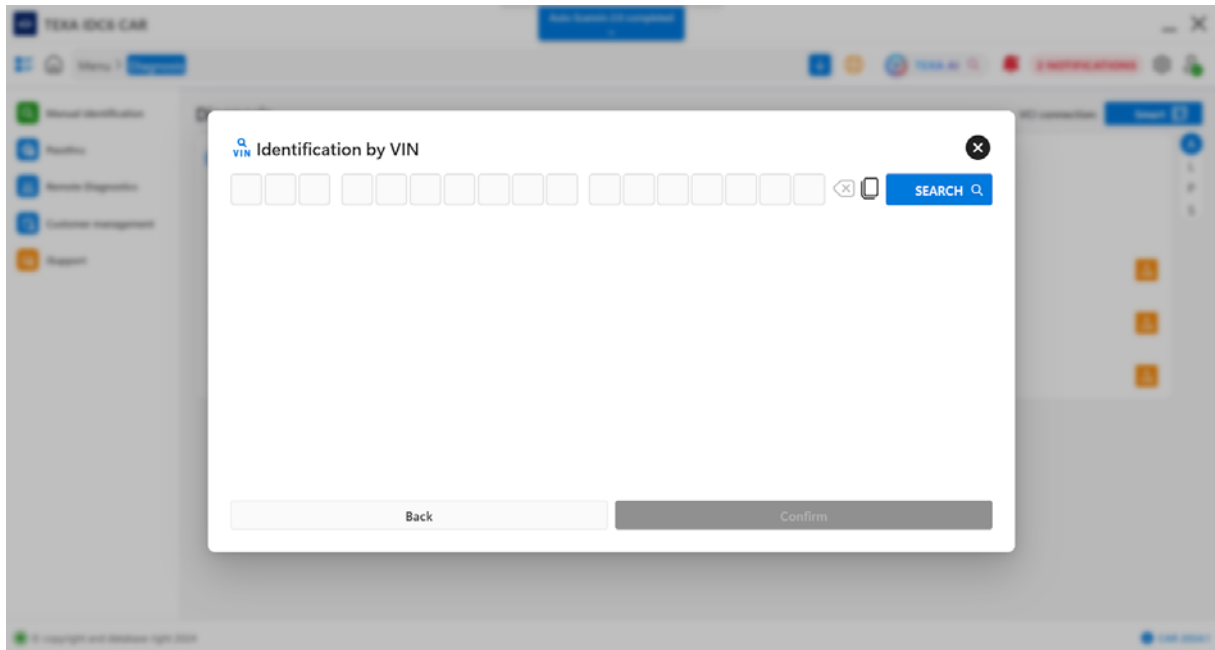

2b. Engine code search

It allows searching for vehicles by entering the engine code.

Note: You are required to enter at least two characters in order to launch the search.

Press:  123

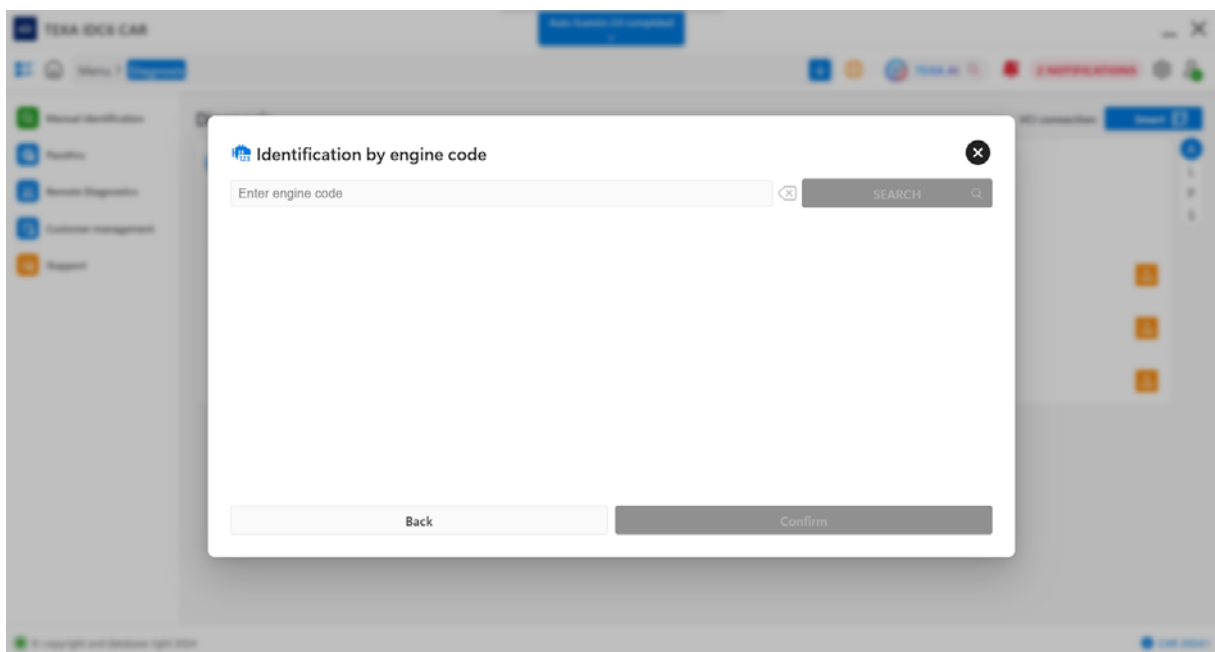

2c. Licence plate number search

It allows searching for vehicles, among the ones previously stored in the "Customer Management" archive, by entering the licence plate number or part of it.

Press: 

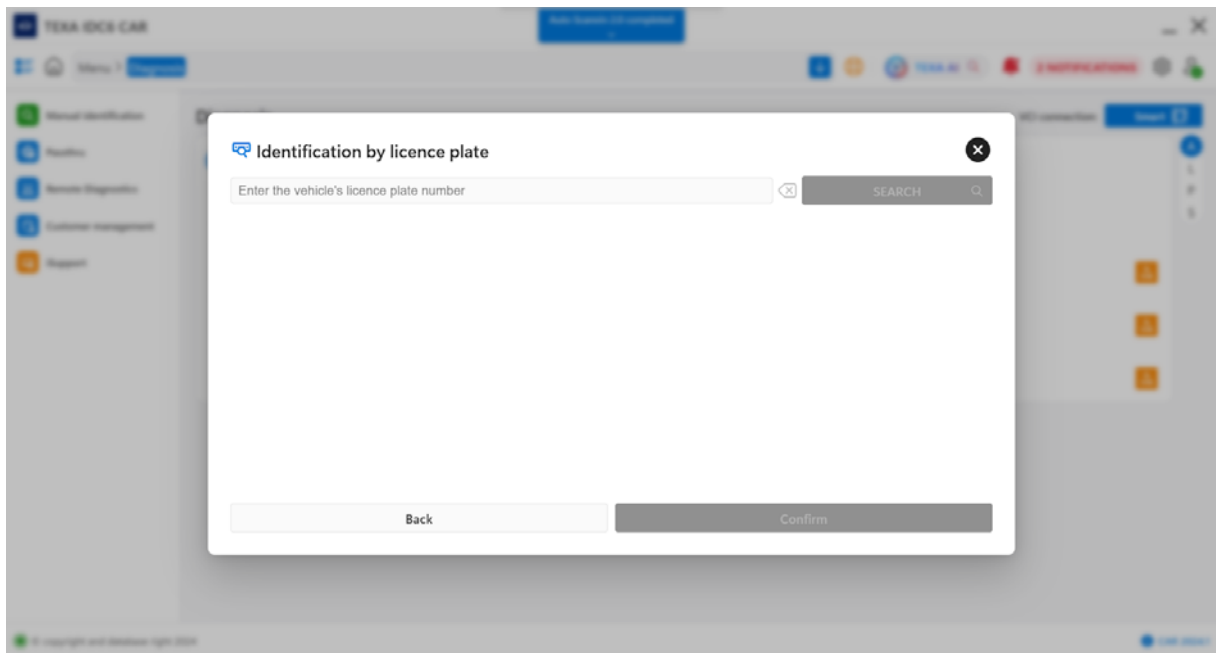

3. Enter the required data.

4. Press:**SEARCH**

5. Select the desired vehicle.

6. Press:**Confirm**

The selection has been carried out.

17 MANUAL VEHICLE SELECTION



The vehicle you wish to work on can be selected manually.

The selection is made by choosing among the options available in the drop down menu of the specific fields:

- *Category*
- *Make*
- *Model*
- *Engine type*
- *Vehicle Code*

These fields make up the **selection levels**.

In order to go from one selection level to the next you must first complete the level you are currently in.

Example: You cannot select the **Make** if first you have not selected the **Category**.

The makes, models and engine types are in alphabetical order.

For quick access to the items within the different selection levels you can:

- *Use the vertical scroll bar.*
- *Press the first letter of the desired make / model / engine type directly on your keypad.*
- *Press on the first letter of the desired make / model / engine type in the list displayed on the right of your screen.*

The **selection** is **complete** when an item has been selected for each of the levels suggested.

During the selection the following function is also available:

Icon	Name	Description
	Scan VIN 2.0	It allows automatically identifying the vehicle the diagnostic device is connected to.

INFORMATION

During the selection, in the side menu on the left icons appear that allow you to access functions which are specific for the level of selection.

Proceed as follows:

1. Press: 
2. Select the **Category**.

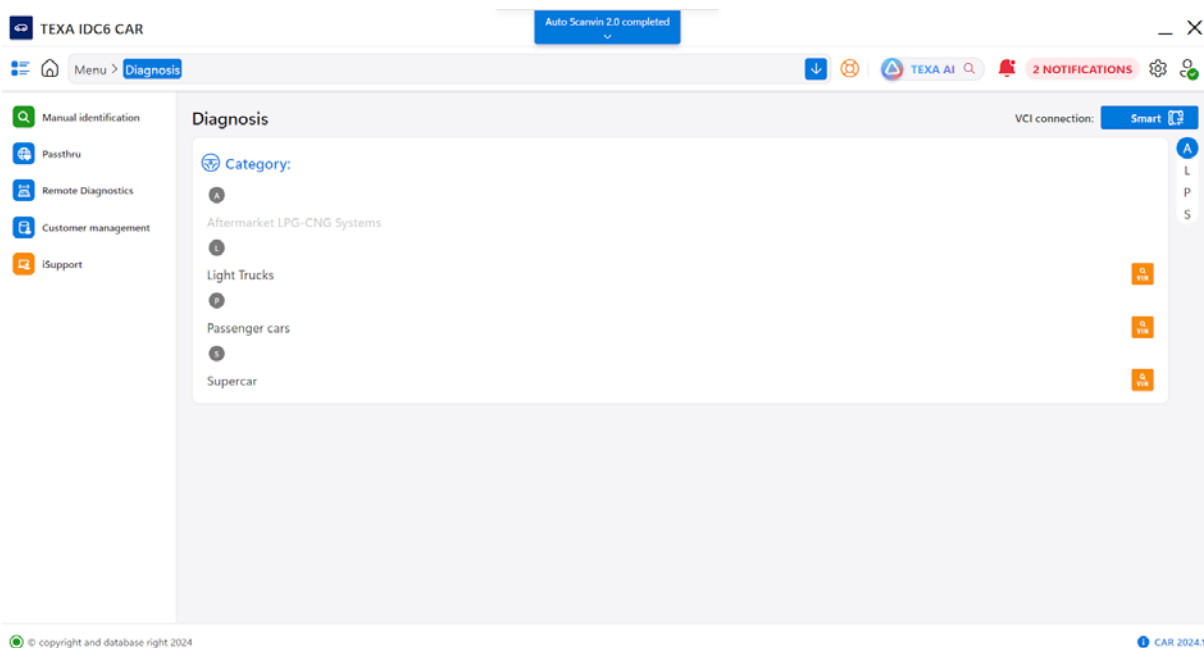

3. Select the **Make**.

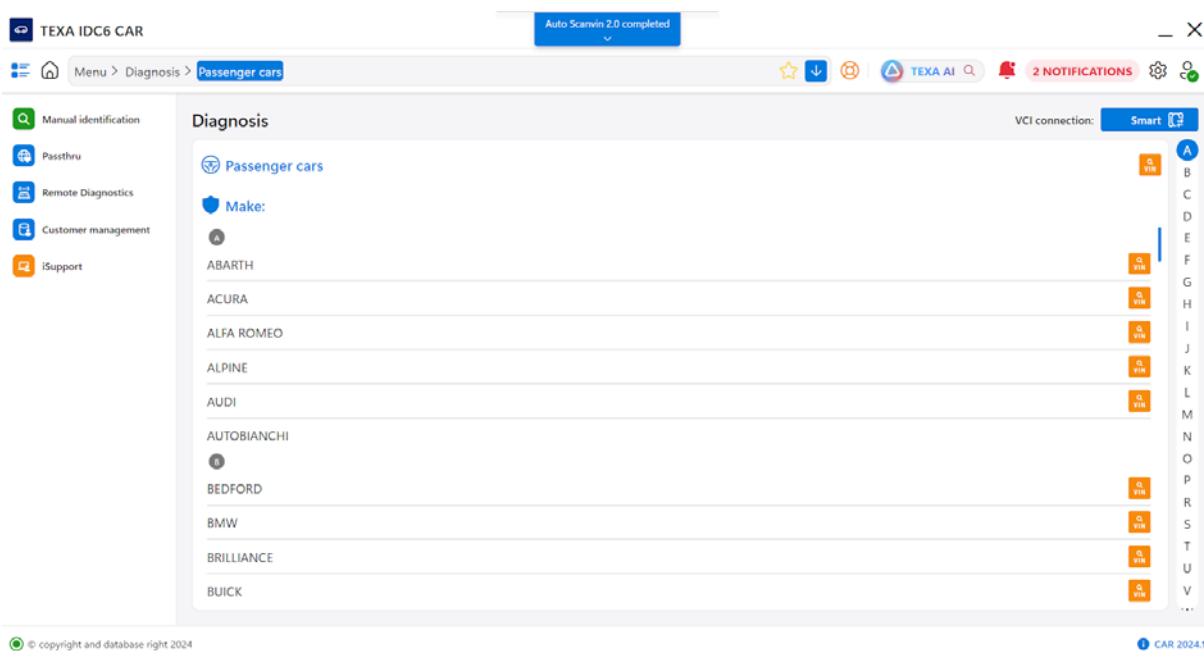

4. Select the **Model**.

The screenshot shows the TEWA IDC6 CAR software interface. At the top, it displays 'TEWA IDC6 CAR' and 'Auto Scanwin 2.0 completed'. The navigation path is 'Menu > Diagnosis > Passenger cars > ALFA ROMEO'. The left sidebar contains options: Manual identification, Technical data sheets, Passthru, Remote Diagnostics, Customer management, and iSupport. The main area is titled 'Diagnosis' and shows 'Passenger cars' and 'ALFA ROMEO'. Under 'Model:', a list of models is displayed:

- 145 [94>00]
- 146 [94>00]
- 147 [00>10]
- 155 [92>98]
- 156 [97>05]
- 156 [97>05] Sport Wagon
- 159 [05>13]
- 159 [06>13] Station Wagon
- 164 [87>98]

The right sidebar shows a vertical list of letters: 1, 3, 4, 7, 9, A, B, C, G, M, R, S, T. The VCI connection is set to 'Smart'. Copyright information at the bottom reads '© copyright and database right 2024' and 'CAR 2024.1'.

5. Select the **Engine type**.

The screenshot shows the TEWA IDC6 CAR software interface. At the top, it displays 'TEWA IDC6 CAR' and 'Auto Scanwin 2.0 completed'. The navigation path is 'Menu > Diagnosis > Passenger cars > ALFA ROMEO > 147 [00>10]'. The left sidebar contains options: Manual identification, Technical data sheets, Passthru, Remote Diagnostics, Customer management, and iSupport. The main area is titled 'Diagnosis' and shows 'Passenger cars', 'ALFA ROMEO', and '147 [00>10]'. Under 'Engine:', a list of engine types is displayed:

- 1.6i 16v T.S. Kat
- 1.9 16v JTDm
- 1.9 8v JTD
- 1.9 8v JTDm
- 2.0i 16v T.S. Kat
- 3.2i V6 Kat GTA

The right sidebar shows a vertical list of numbers: 1, 2, 3, 5. The VCI connection is set to 'Smart'. Copyright information at the bottom reads '© copyright and database right 2024' and 'CAR 2024.1'.



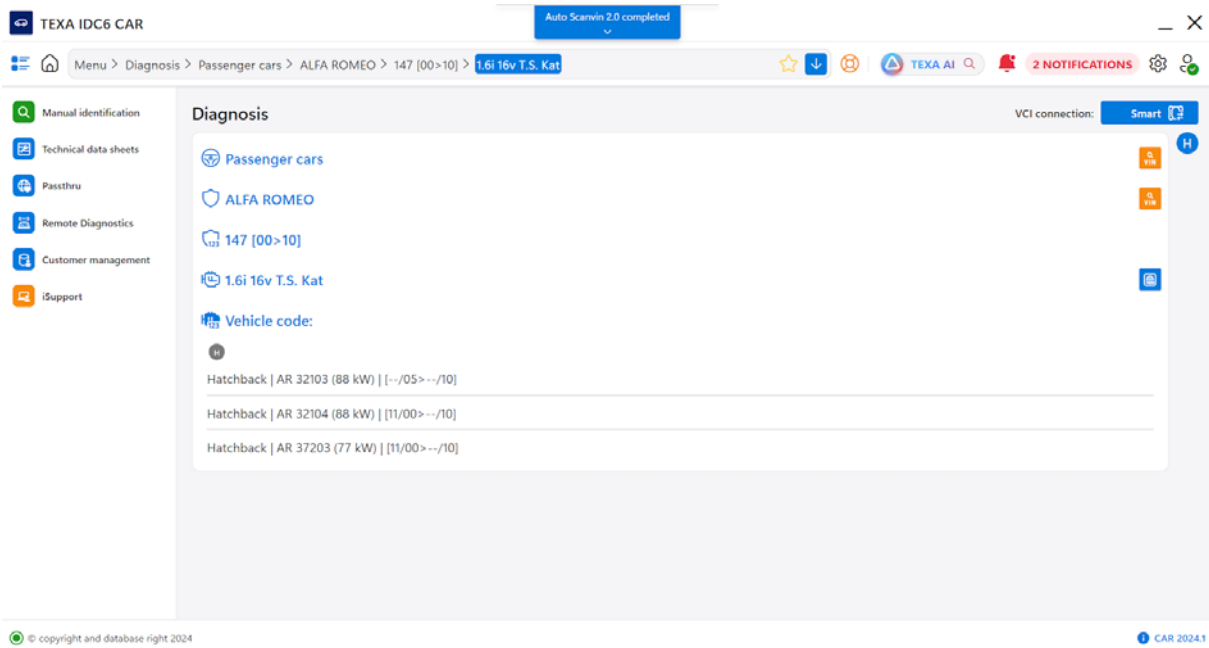

6. Select the Vehicle Code.

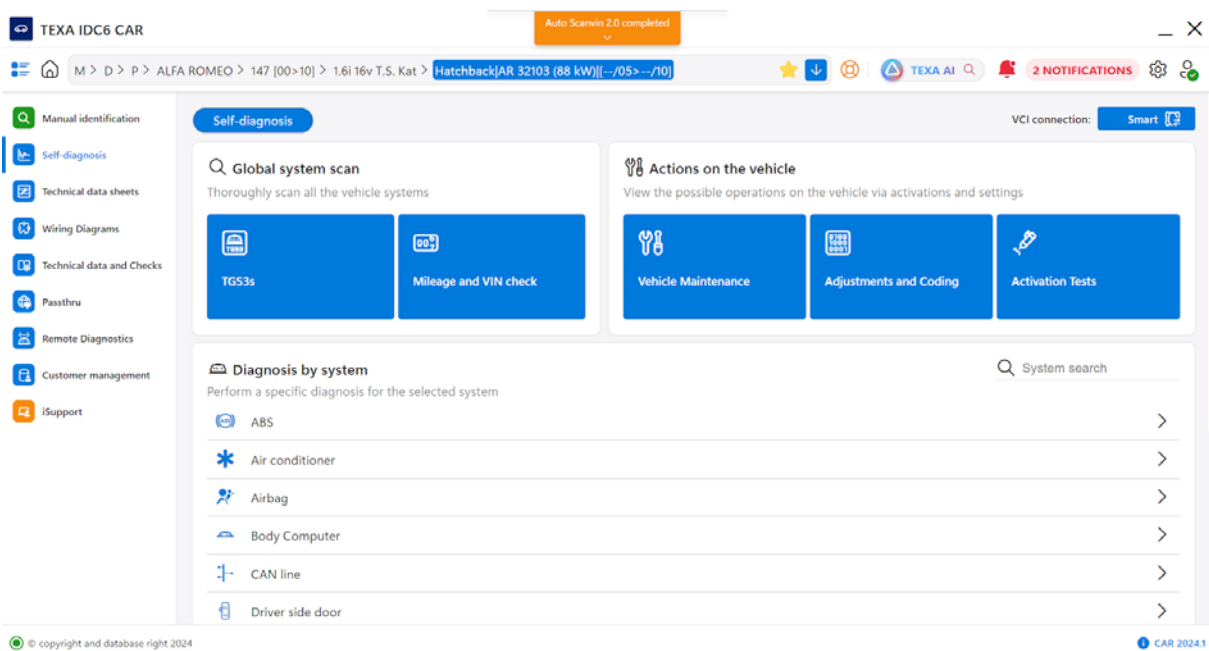

The selection is complete.



In this screen there is:

Icon	Name	Description
	Side menu	It allows accessing the functions specific for the selection made.
	Global System Scan	It gathers the software functions that allow running a detailed scan on all the vehicle systems.
	Actions on the vehicle	It gathers the software functions that allow displaying the operations that can be done on the vehicle through activations and adjustments.
	Diagnosis by system	It allows performing a specific diagnosis for the selected system.

INFORMATION

At the end of the selection, you can add the vehicle to the list of

en

selections saved by pressing: 







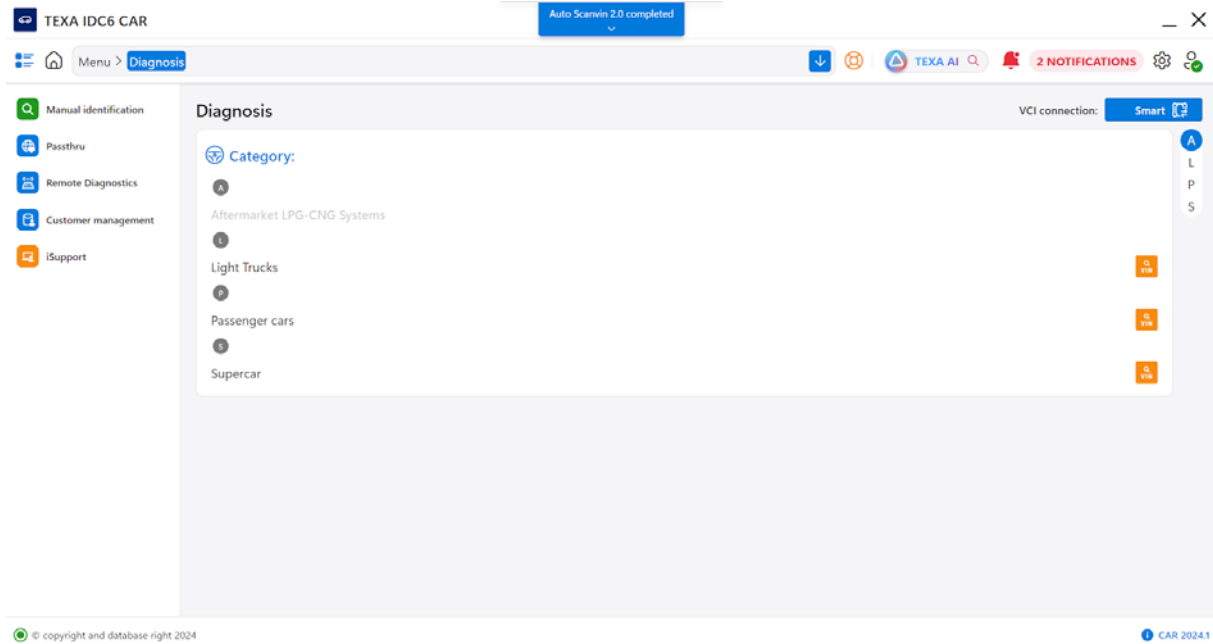

17.1 Side menu













In this section you can access the specific functions for the selection made.

1. Press: 

The side menu is displayed.



Icon	Name	Description
	Manual identification	It allows selecting a vehicle using search keys such as the VIN, the engine code, or the licence plate number stored in the Customer Management archive.
	Self-diagnosis	It allows accessing the self-diagnosis contents. E.g. Actions on the vehicle, Global system scan, etc.
	Technical data sheets	It allows accessing the support information in specific pages that appear when selecting the vehicle.
	Guided Diagnosis	It allows displaying the technical sheets with the procedure to perform the diagnosis.
	Vehicle maintenance	It allows accessing the ACTIVATIONS and SETTINGS functions for the specific component selected.
	Adjustments and codings	It allows accessing the Settings function for the specific component selected.
	Device check	It allows accessing the Activations function for the specific component selected.
	Alignment Check	It allows checking the vehicle alignment.
	ECU Update	It allows updating the firmware for the control units installed in the vehicle.

	Special Functions	It allows accessing a subset of particularly relevant and frequently used functions.
	Maintenance service	It allows quickly accessing all the functions relating to the vehicle maintenance.
	PARTNERS' LINKS	It allows accessing the portal with the links to the TEXA partners' websites.
	Wiring Diagrams	It allows displaying the wiring diagrams related to the selection made.
	Technical data / Maintenance	It allows displaying the technical sheets related to the vehicle maintenance.
	Technical data and Checks	It allows getting information related to the vehicle maintenance and repair, technical drawings, assistance procedures, technical bulletins and recalls.
	Diagnostic coverage list	It allows accessing the list of vehicles, systems and new features available in the installed version of the current environment.
	Texa Tension Control	It allows viewing the documents about how to use the TEXA TTC device, with information on the timing belt tensioning values.
	Special Code	It allows viewing the status of the off-line mode for the Special Code service to carry out the Special Settings.
	Passthru	It allows accessing the Pass-Thru services.
	Remote diagnosis	It allows remote diagnosis connecting to the TEXA Call Center.
	Customer management	It allows managing the workshop's customer archive.
	iSupport	It allows accessing the on-line assistance function.

INFORMATION

Some functions may not be available for all the environments or on all the platforms.

18 TGS3s



This function allows you to access information related to the systems in the vehicle.

To launch the function, you must select at least the **Category**, **Make**, **Model** and **Engine type**.

The scan procedure is able to:

- *Verify the presence of the selected systems.*
- *Check if the system unit has been identified univocally or not *.*
- *Check if the system that responded has any errors.*

(*) The **incorrect detection** indicates that the specific system responded unexpectedly to the selection carried out on the systems list.

In these cases, the communication between the diagnostic device and the system is possible, but the quality of the diagnosis is not guaranteed and all the coding and / or programming functions are disabled.

Ex.: By launching the TGS3s function, three different automatic transmission systems are displayed for the same vehicle.

Only one of these three is the correct one.

If the user is not able to identify the correct system type, it is possible to select the three options suggested by TGS3s.

The result is that only one of the three systems will be identified univocally.

The function allows you to select a system and start its diagnosis.

Proceed as follows:

1. Press: 

INFORMATION

The software may request you:

- *to select the type of diagnostic protocol you intend to use (Standard, DoIP, CAN, etc.).*
- *to select the cable or the elements you intend to use.*
- *to select for which areas (Europe, United States, etc.) to start the system scan.*

INFORMATION

Based on the VCI in use and selection performed, a screen may be displayed with useful information for the connection to the VCI.



The images and videos may vary based on the vehicle and type of diagnosis (Standard, DoIP, CAN, etc.) selected.

2. Press:OK

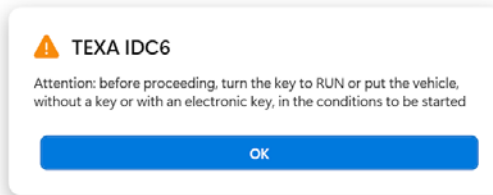

Wait for the scan to be complete.

The result of the scan is displayed.

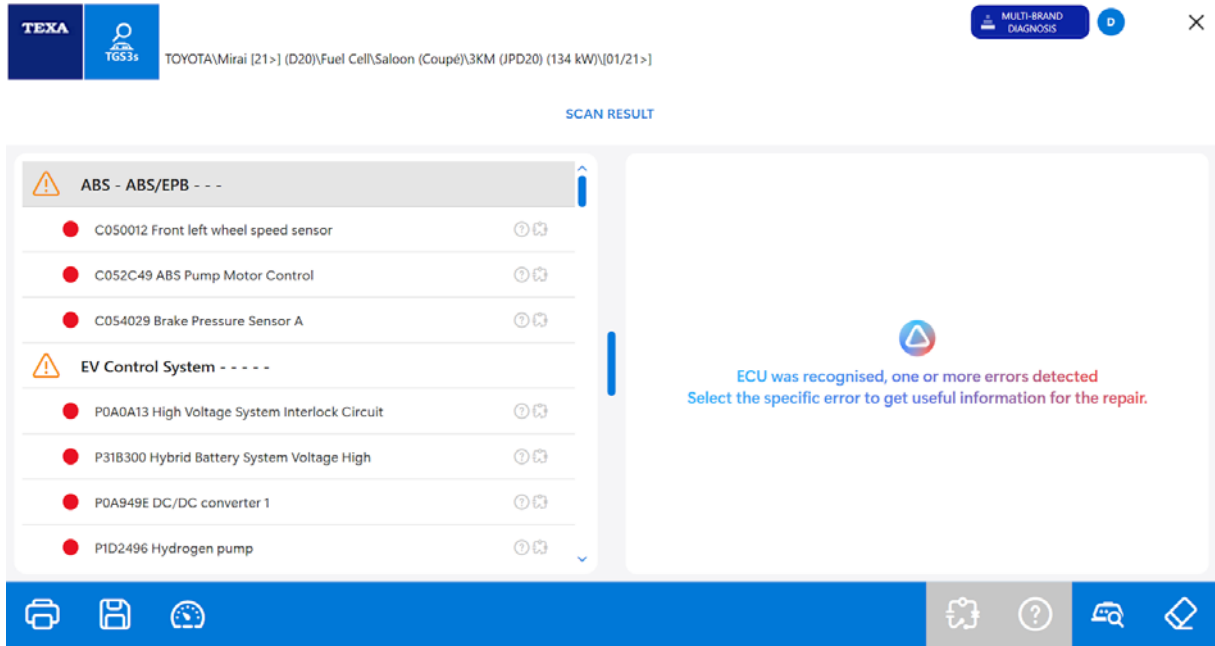

The detected errors are grouped by system.
The icon next to each system indicates:

Icon	Description
	The system was detected and there are not any errors.
	The system was not detected. It is possible that the model you are working on does not have the system at issue or that the system is not responding correctly to the request.
	The system was detected and there is at least one error.
	The system was not detected univocally.

3. Select the desired error.

4. The AI SMART DIAGNOSIS functions available for the performed selection are displayed.

The screenshot shows the AI SMART DIAGNOSIS interface for a Toyota Mirai. The vehicle information at the top is: TOYOTA\Mirai [21>] (D20)\Fuel Cell\Saloon (Coupé)\3KM (JPD20) (134 kW)\01\21>. The interface is titled 'SCAN RESULT' and shows a list of error codes under two main categories: 'ABS - ABS/EPB' and 'EV Control System'. The selected error is C050012 Front left wheel speed sensor. The right panel provides detailed information and recommendations for this error.

Information on the error

The error code C050012 indicates a problem with the front left wheel speed sensor, specifically a short circuit to positive. This sensor is crucial as it detects the wheel speed and sends the signal to the control unit to manage braking. Possible components involved include the front left wheel speed sensor itself, the connection of the front left anti-skid sensor, the connector and cable, and the anti-skid control unit.

Recommendations:

- If you replace the anti-skid control unit, ensure to perform the "Calibration" adjustment.
- After replacing or reinstalling the speed sensor, conduct the "Test mode" adjustment to verify proper sensor functionality.

[C050012 - FRONT LEFT WHEEL SPEED SENSOR](#)

Icon	Name	Description
	Print	It allows printing a report containing the detected errors.
	Save	It allows recording the detected errors and saving them in the Customer Management archive.
	Dashboard	It allows you to access the DASHBOARD function. The function allows viewing a graphical representation of the vehicle that is useful for the diagnostic operations.
	Component location	It allows finding the component affected by the error through the Wiring Diagrams function.
	Information	It allows displaying a help screen related to the selected error.
	Diagnosis	It allows you to launch the diagnosis on the selected system.
	Deleting Faults	It allows deleting the errors detected on all the systems available .

For further information, see the chapter: AI SMART DIAGNOSIS

19 DIAGNOSIS BY SYSTEM



This function allows performing a specific diagnosis for the selected system.

The functions and the operating procedures of each electronic system are defined by the manufacturer of the control unit and of the vehicle.

However, the methods of use by the operator for the software remain the same.

Proceed as follows:

1. Select the desired system.

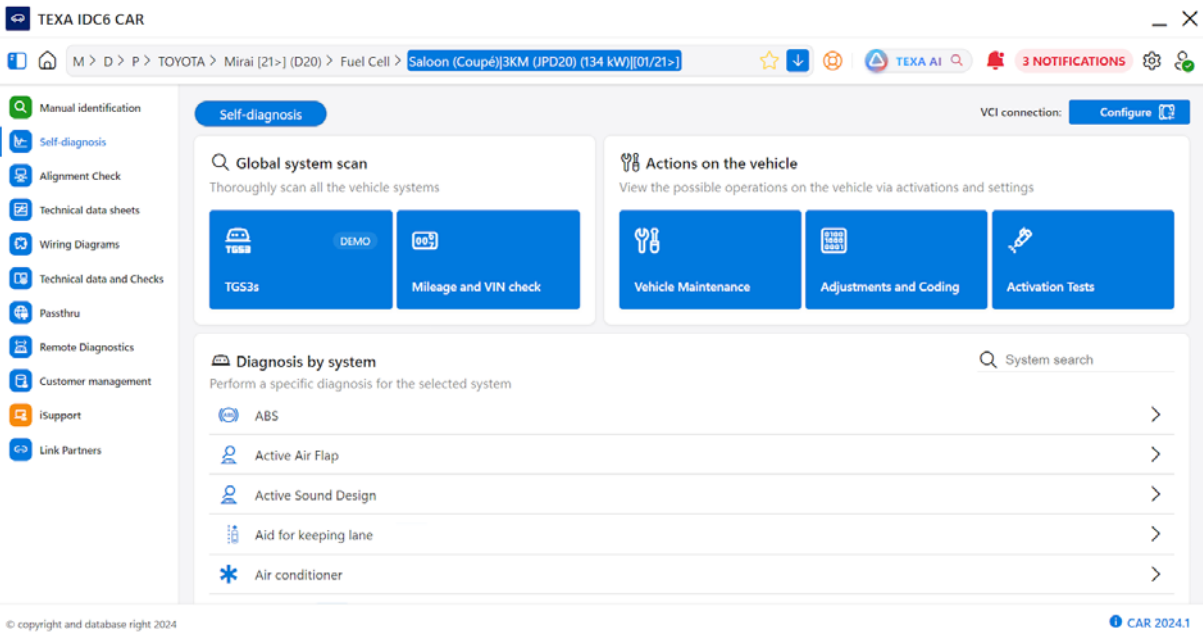

2. Press: **START**

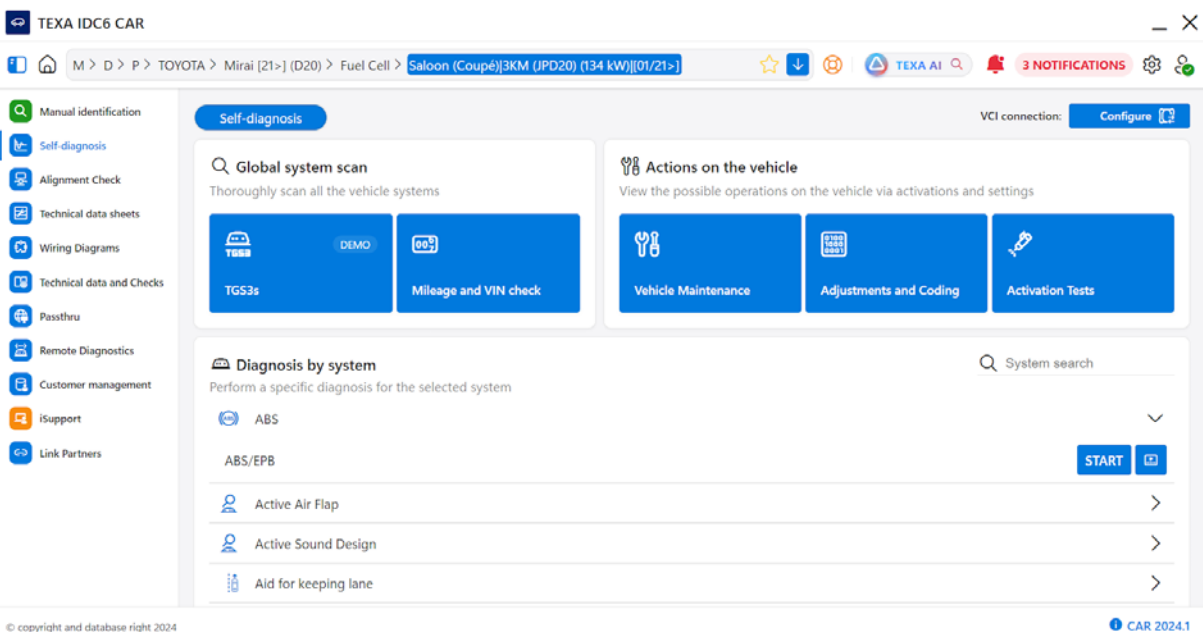

INFORMATION

Based on the VCI in use and selection performed, instead of the **START** icon, the software may show the icons of the diagnostic protocols available for the selected system.

To continue, press the icon of the desired diagnostic mode.

3. Follow the instructions that appear on screen.

4. Press: **CONFIRM**





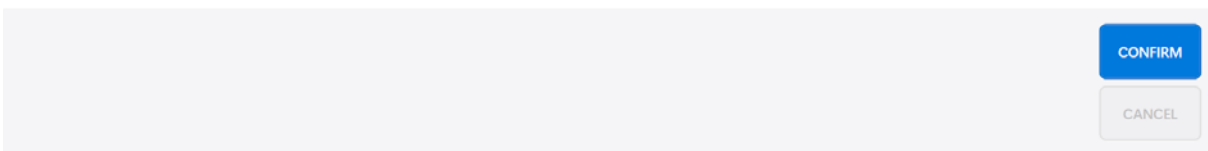



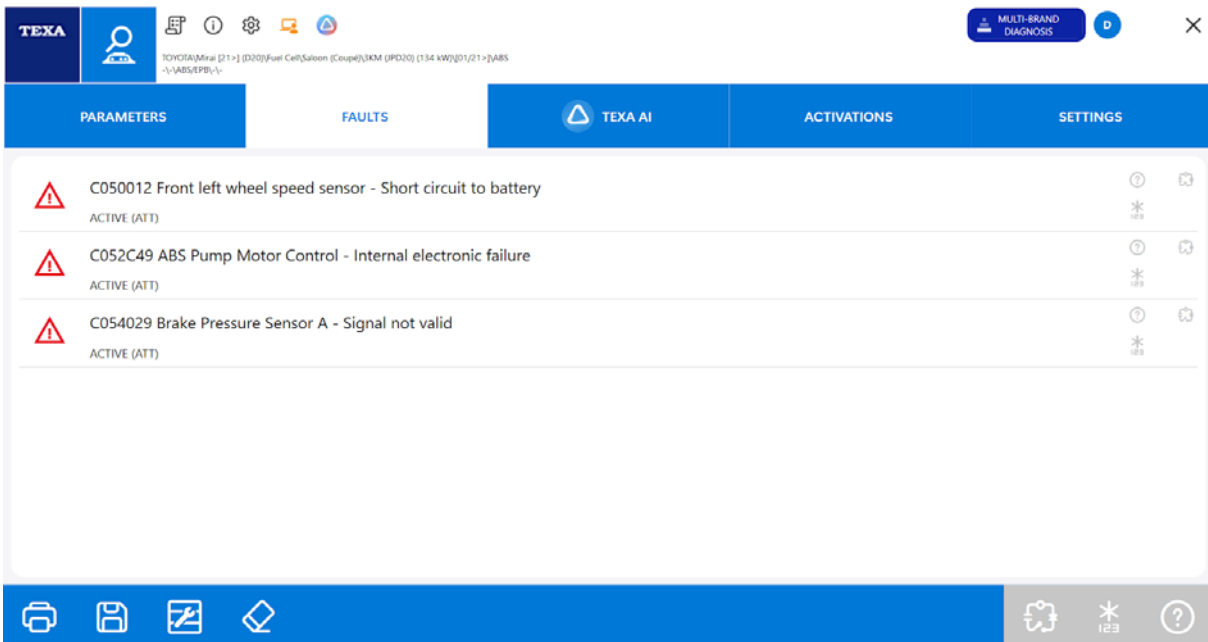

Turn on the instrument panel
Press CONFIRM



The software displays the errors page.



In the upper part of the screen, the following is available:

Icon	Name	Description
	ToolTips	It allows viewing the legend of the icons used in the current page.
	Information	It allows viewing information regarding the VCI in use.
	Settings	It allows selecting the system of measurement to be used.
	VCI connection	It allows displaying the mode the VCI is connected with. The icon will change based on the connection mode used.
	iSupport	It allows sending support and/or specific diagnostic content development requests.
	Fault notification	It allows sending data and information on operations carried out during the diagnosis but not successful.
	Off-line special code	It allows viewing the number of remaining off-line special settings.
	TEXA AI	It allows launching the search function powered by AI.

In the central part of the screen, the following is available:

Name	Description
Parameters	It allows managing the monitoring of the parameters provided by the control unit.
Errors	It allows displaying and deleting the errors detected by the control unit.
TEXA AI	It allows using the AI SMART DIAGNOSIS functions.
Status	It allows viewing the statuses that the specific data provided by the software acquires.
ECU info	It allows viewing information related to the control unit you are connected to and identifying it correctly.
Activations	It allows testing the operation of specific actuators (components piloted by the control unit) by activating them temporarily.
Adjustments	It allows performing permanent adjustments on specific electronic components.

INFORMATION

Based on the selection carried out, some Diagnosis Functions may not be available.

For some selections, it is possible to view the parameters and statuses within a single screen.

This type of display makes the diagnosis less dispersive and it also makes it easier to gather information.

In the lower part of the screen, the specific functions for the current page are available.

19.1 Parameters

In this page you can manage the monitoring of the engineering parameters provided by the control unit.

The control unit provides the parameters detected by the sensors and sent to the actuators (i.e. rpm sensor, injectors, temperature, pressure sensors, etc.) as numerical values, updated in real time.

The minimum and maximum values of these parameters are analysed and their trend can be displayed graphically.





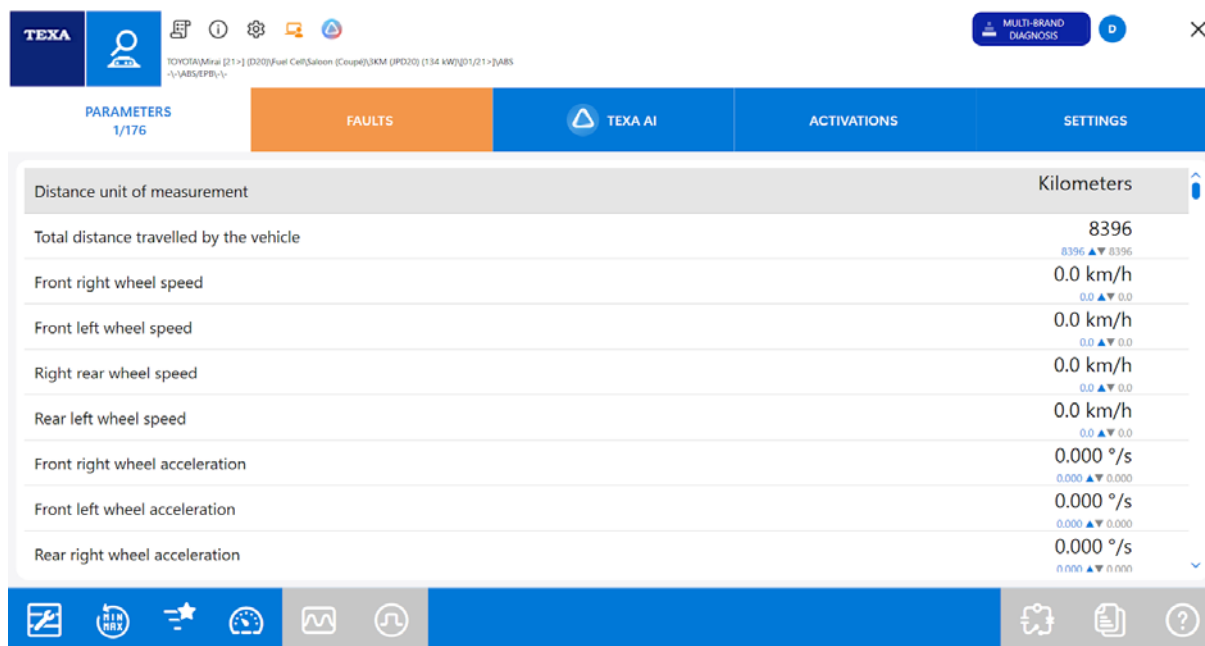

Proceed as follows:



1. Press:PARAMETERS



INFORMATION

By pressing twice on a parameter, you can start the graphic display.

Icon	Name	Description
	Technical Documentation	It allows you to view the documentation regarding the diagnosis being carried out.
	Min Max Reset	It allows resetting the minimum and maximum values detected for the parameters displayed.
	Favourite Parameters	It allows you to create a group of favourite parameters in order to access them more easily.
	Dashboard	It allows viewing a graphical representation of the vehicle that is useful for the diagnostic operations.
	Oscilloscope	It allows displaying graphically the trend of an electric signal over time.
	Signal generator	It allows you to simulate the input and output signals of the electronic control units used in vehicles.

	Component location	It allows finding the component affected by the error through the Wiring Diagrams function.
	Self-diagnosis Component Sheets	It allows you to view information related to the component the selected parameter refers to.
	Information	It allows displaying a help screen related to the selected parameter.

This screen provides the following information:

- **Description:** *description of the parameter.*
- **Value:** *instant value.*
- **UM:** *unit of measurement*
- **Max:** *maximum value recorded from the beginning of the test.*
- **Min:** *minimum value recorded from the beginning of the test.*

19.1.1 Favourite Parameters

This function allows filtering the parameters to get a focused view on the most relevant information, and displaying and managing the groups of favourite parameters created.

In order to find the parameters to filter easily, you can use the text field in the lower part of the screen.





The favourites are organised in pages as the **Diagnosis Functions**.

A new page is created for each group of favourites and it can be selected simply clicking the corresponding label.

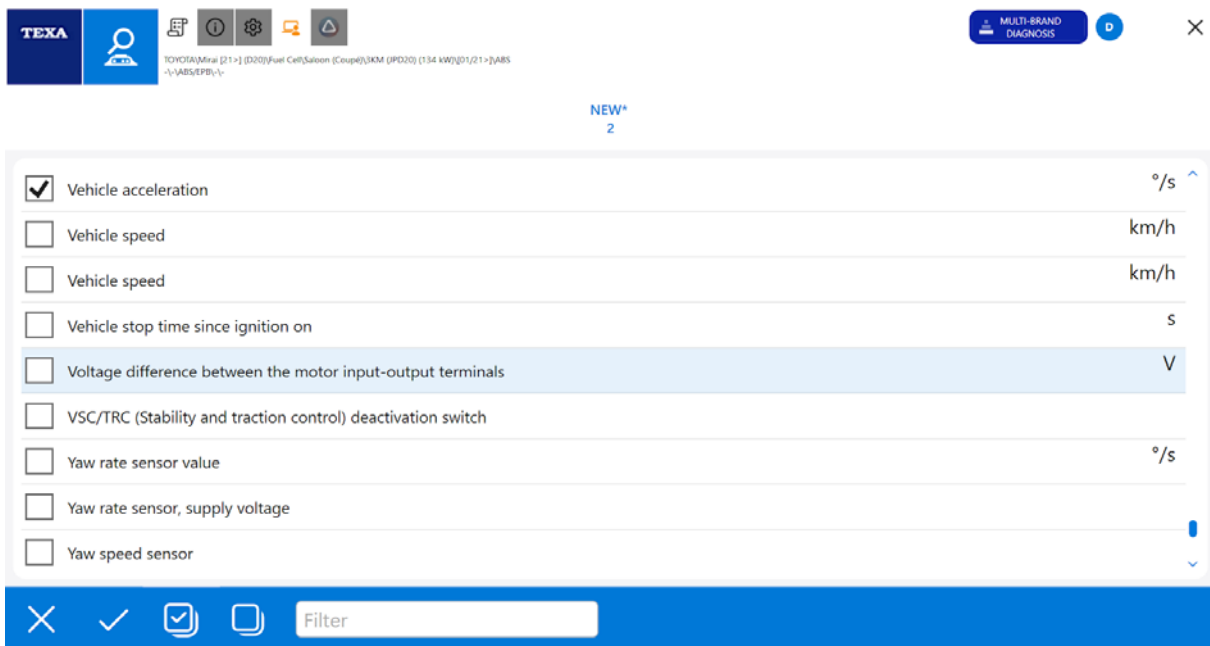
Proceed as follows:

1. Press: 
2. Select the desired parameters.









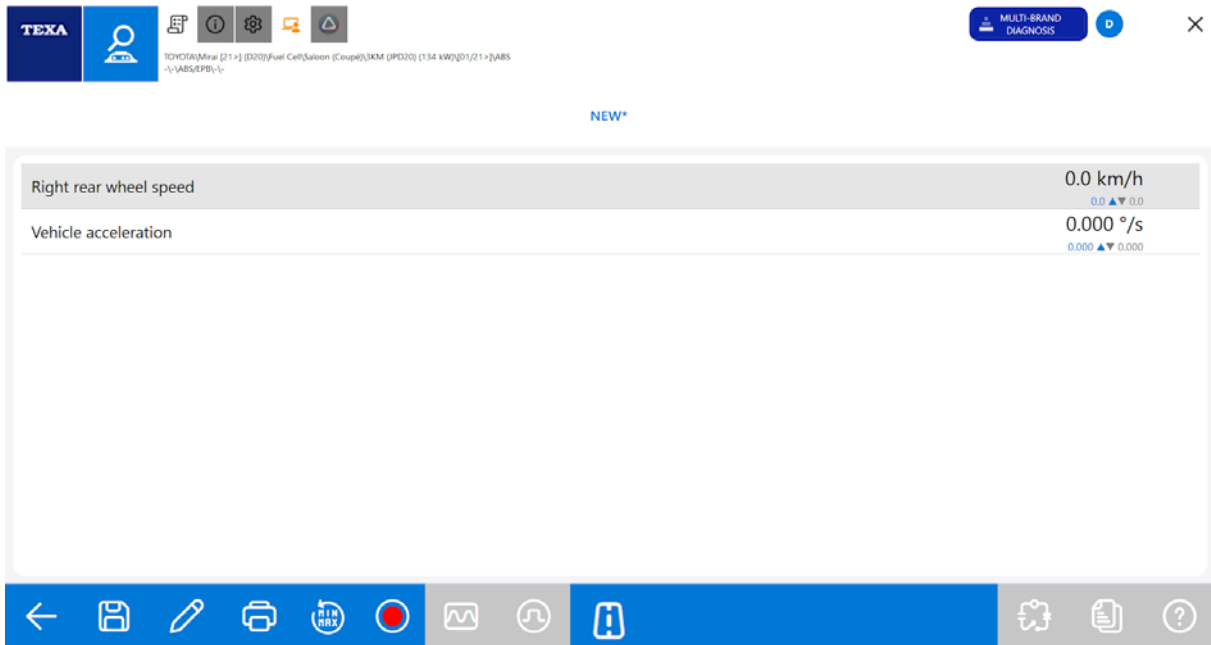





Icon	Name	Description
	Cancel	It allows you to cancel the creation operation.
	Confirm	It allows you to confirm the parameters selected.
	Select All	It allows you to select all the available parameters.
	Deselect All	It allows you to deselect all the available parameters.

3. Press: 

The filter has been set.



Icon	Name	Description
	Save	It allows you to save the group of favourite parameters and assign it a name.
	Change Group	It allows changing a group of favourite parameters by adding or deleting some.
	Add Group	It allows you to create a new group of favourite parameters. The icon will be visible only after saving the group of favourite parameters.
	Delete Group	It allows you to delete a group of favourite parameters.
	Print	It allows you to print a report that indicates the values of the parameters.
	Min Max Reset	It allows resetting the minimum and maximum values detected for the parameters displayed.
	Registration	It allows you to record the values of the parameters the selected group of favourites is composed of. The recording is saved in the Customer Management archive.
	Oscilloscope	It allows displaying graphically the trend of an electric signal over time.
	Signal generator	It allows you to simulate the input and output signals of the electronic control units used in vehicles.
	Dynamic Tests	It allows configuring the VCI for the recording of parameters, statuses and errors detected by the control units in a moving vehicle or boat. (*)
	Component location	It allows you to find the component affected by the error through the Wiring Diagrams function.

	Device Sheets	It allows you to access the technical sheets related to the most complex components installed on the vehicle (common rail injectors, digital mass flow sensors, etc.).
	Information	It allows displaying a help screen related to the selected parameter.

(*) *The icon that allows selecting the function will appear only after a group of favourite parameters has been created.*

19.1.2 Recording (Favourite Parameters)

This function allows you to record the values of the parameters the selected group of favourites is composed of.

The recording is saved in the **Customer Management** archive.

Proceed as follows:

1. Press: 
2. Set the length of the recording using the cursor

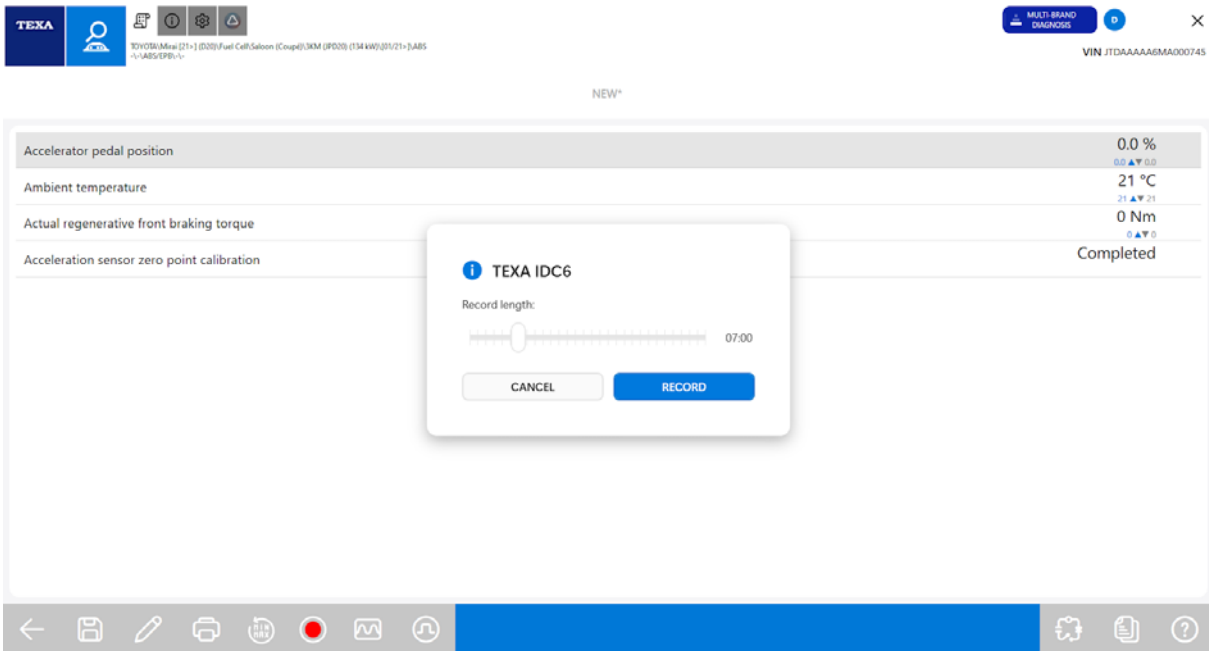

3. Press: **Record**

The recording is started.

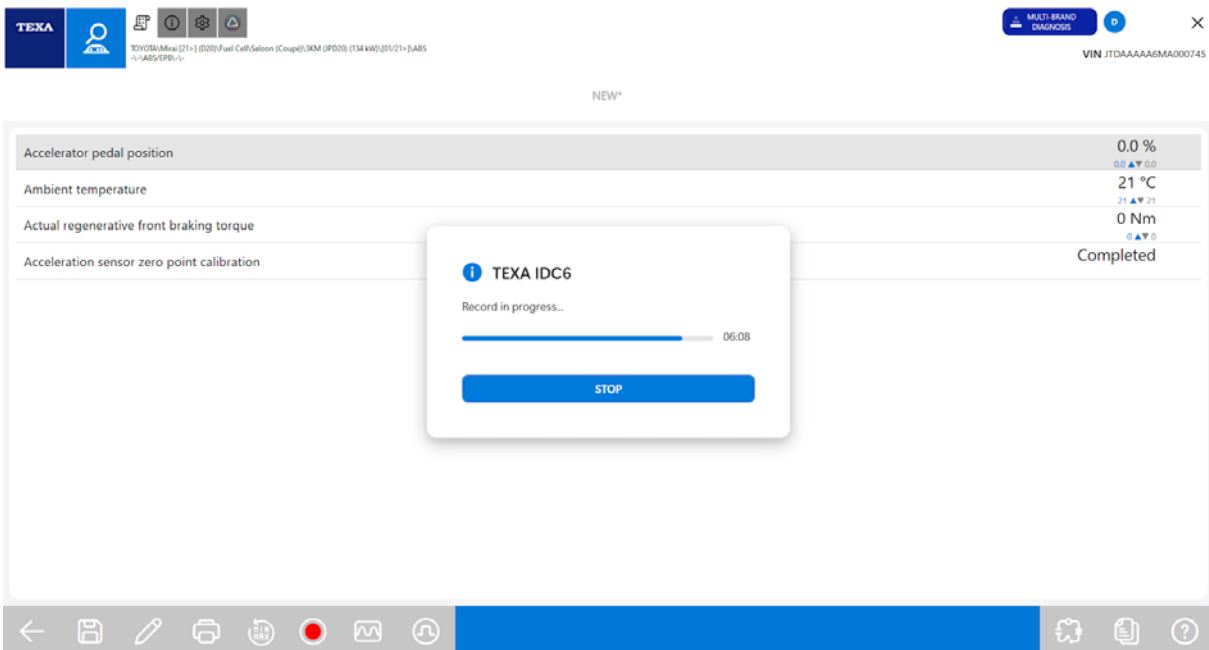

4. At the end of the recording, or if you press **STOP**, the following screen is displayed.

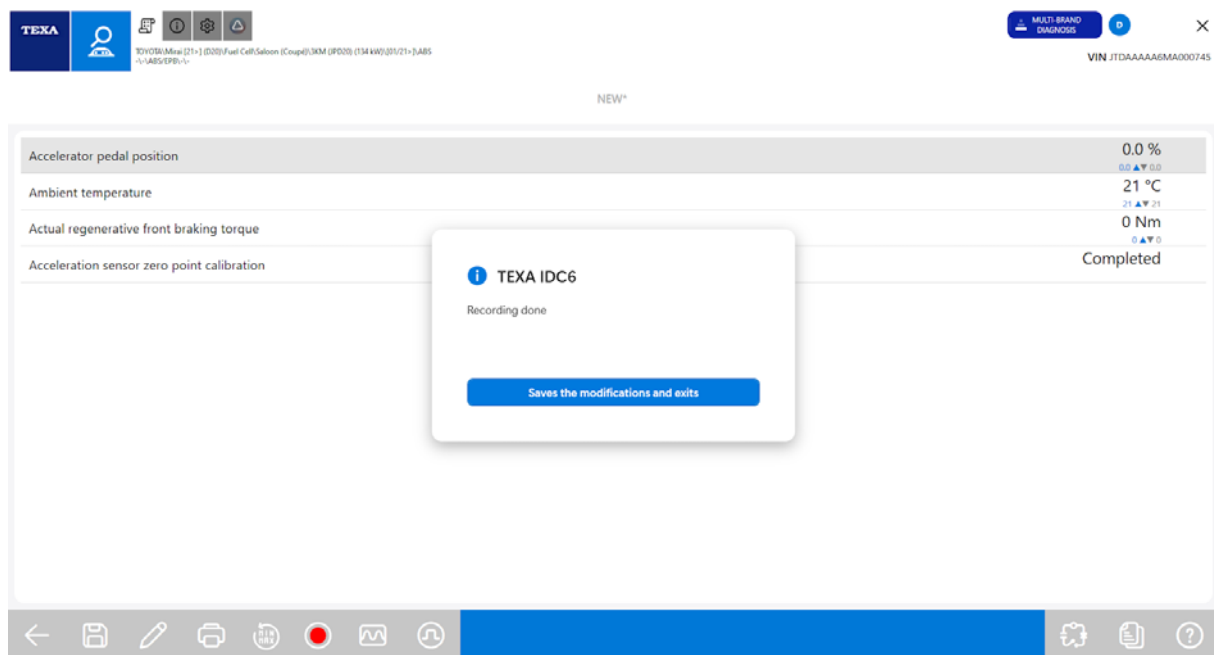

5. Press: **Saves the modifications and exits**

At the end of the diagnosis, the **Customer Management** function is launched.

19.2 Errors

In this page you can also view and delete the errors that have been detected by the control unit while the engine was running.



The control unit stores these errors in a permanent memory.

This allows the operator to understand whether the malfunctions occurs in specific conditions or if it is always present.

Once the error has been reported, the software provides information on the type of malfunction.

The operator may try to repair the malfunction and then proceed deleting the error from the control unit's memory.

The errors can be marked by three different statuses:

Icon	Status	Description
	Current (ATT)	It indicates the presence of an error during the connection, therefore not stored in the control unit but present at the moment.
	Stored (MEM)	It indicates an error stored in the control unit, but no longer present.
	History (STO)	It indicates that the error previously deleted from the control unit using the Error Clearing function, is now stored in the diagnostic device's memory.

If the memory no longer contains errors at the following diagnosis, this means the malfunction was deleted correctly.





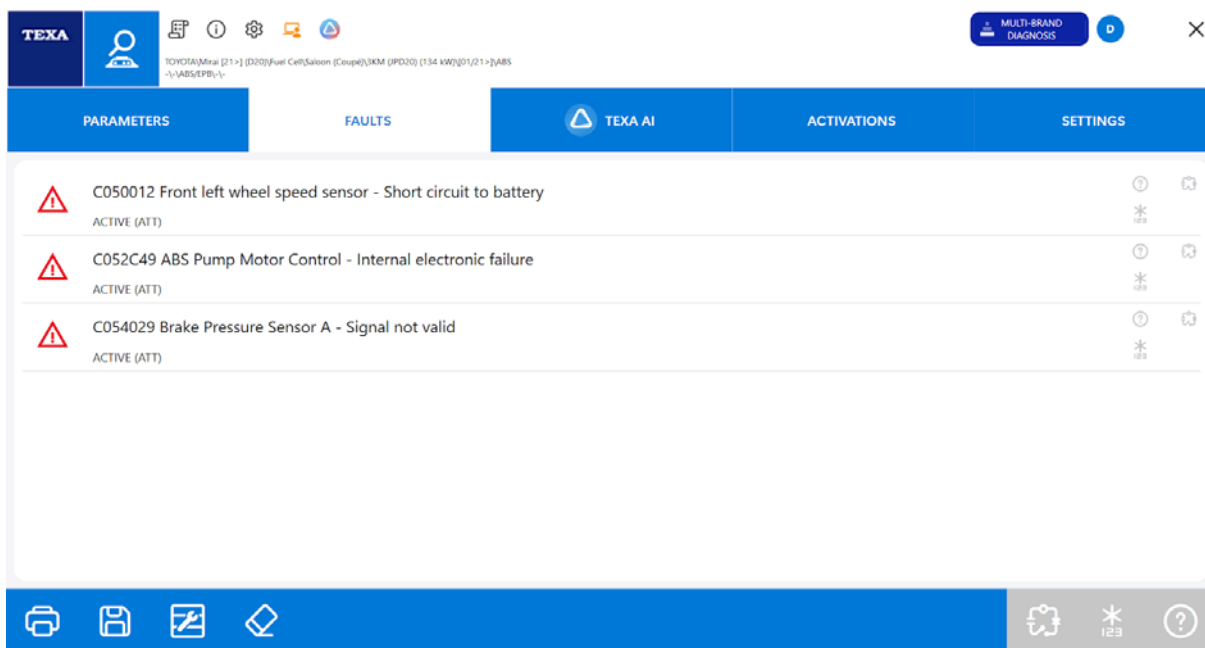

INFORMATION

In some systems, malfunctions of sensors on the lines connected to the control unit are detected only in certain conditions (i.e. only when the vehicle is stationary and with the instrument panel on or only when the vehicle is moving).

Proceed as follows:

1. Press: **FAULTS**



Icon	Name	Description
	Print	It allows you to print a report related to the detected errors.
	Save	It allows recording the detected errors and saving them in the Customer Management archive.
	Technical Documentation	It allows you to view the documentation regarding the diagnosis being carried out.
	Delete Errors	It allows deleting the detected errors.
	Component Location	It allows you to find the component affected by the error through the Wiring Diagrams function.
	Freeze Frame	It allows viewing the freeze frames provided by the control unit.
	Help	It allows displaying a help screen related to the selected error.

19.2.1 Error Clearing

This function allows you to delete the errors from the control unit's memory.

Once the errors have been cleared and are no longer present in the control unit, they are marked by the status **STO**.

If the errors are still present and marked by the status **ATT** the next time communication with the control unit takes place, it means that they have been detected by the control unit again.

Proceed as follows:

1. Press: 
2. Follow the instructions that appear on screen.



Errors deleted
Press CONFIRM

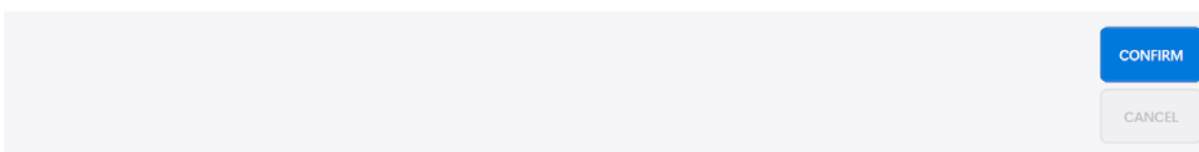

The errors have been cleared.

19.2.2 Freeze Frame

This function allows viewing the freeze frames provided by the control unit.

The freeze frames are a series of parameters that identify the engine's conditions (e.g.: supply system, engine coolant temperature, vehicle speed, etc.) when a malfunction is detected.

The vehicle's control unit, when it detects a malfunction, stores all the freeze frames related to that error code.

The function is useful for the operator since it offers an overview of the vehicle's status when the malfunction occurred.

Proceed as follows:

1. Select the desired error.



The available freeze frames are displayed.

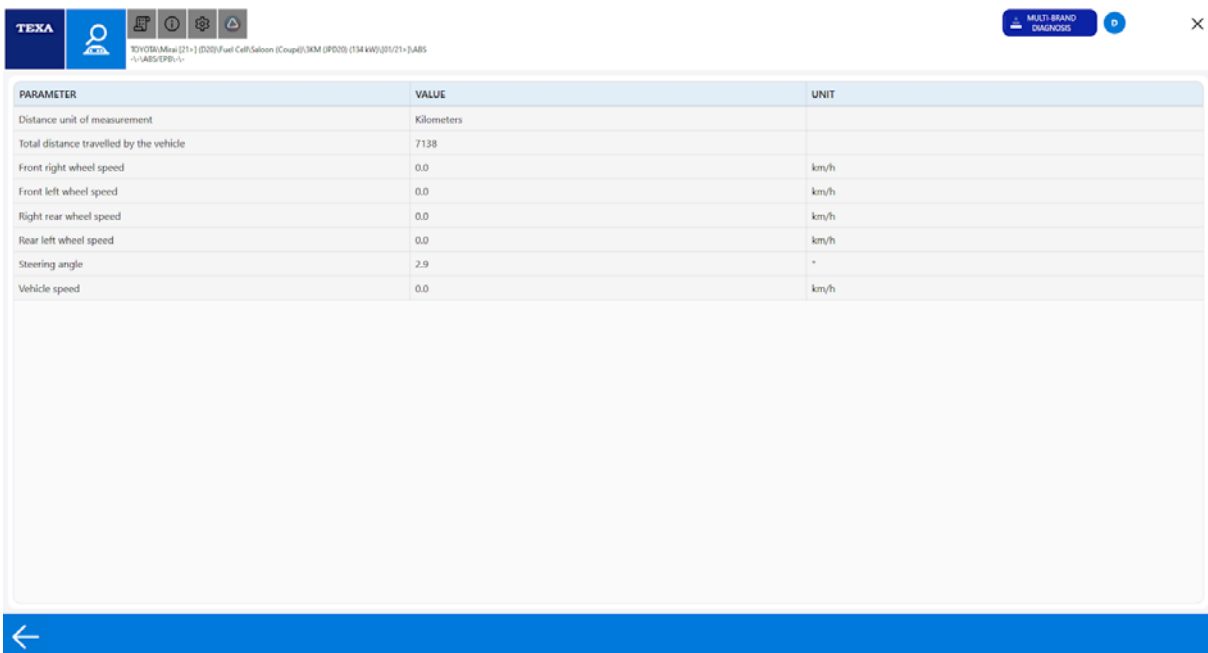

PARAMETER	VALUE	UNIT
Distance unit of measurement	Kilometers	
Total distance travelled by the vehicle	7138	
Front right wheel speed	0.0	km/h
Front left wheel speed	0.0	km/h
Right rear wheel speed	0.0	km/h
Rear left wheel speed	0.0	km/h
Steering angle	2.9	°
Vehicle speed	0.0	km/h

19.3 TEXA AI

This function allows using the AI SMART DIAGNOSIS functions.

Proceed as follows:

1. Press: **TEXA AI**
2. Select the desired error.
3. The AI SMART DIAGNOSIS functions available for the performed selection are displayed.

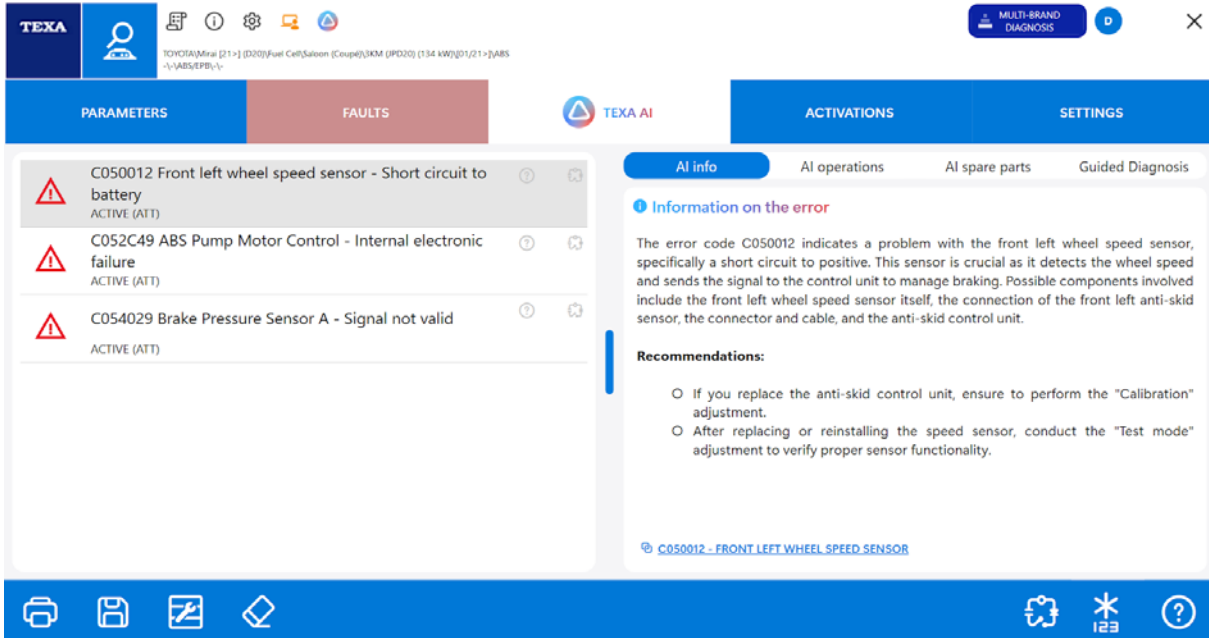

For further information, see the chapter: AI SMART DIAGNOSIS



19.4 Status

In this page you can view the statuses that the specific data provided by the software acquires. This data can only have predefined statuses and conditions, generally indicating ON / OFF (i.e.: Engine running / not running, clutch pedal pressed / released, etc.).

Proceed as follows:

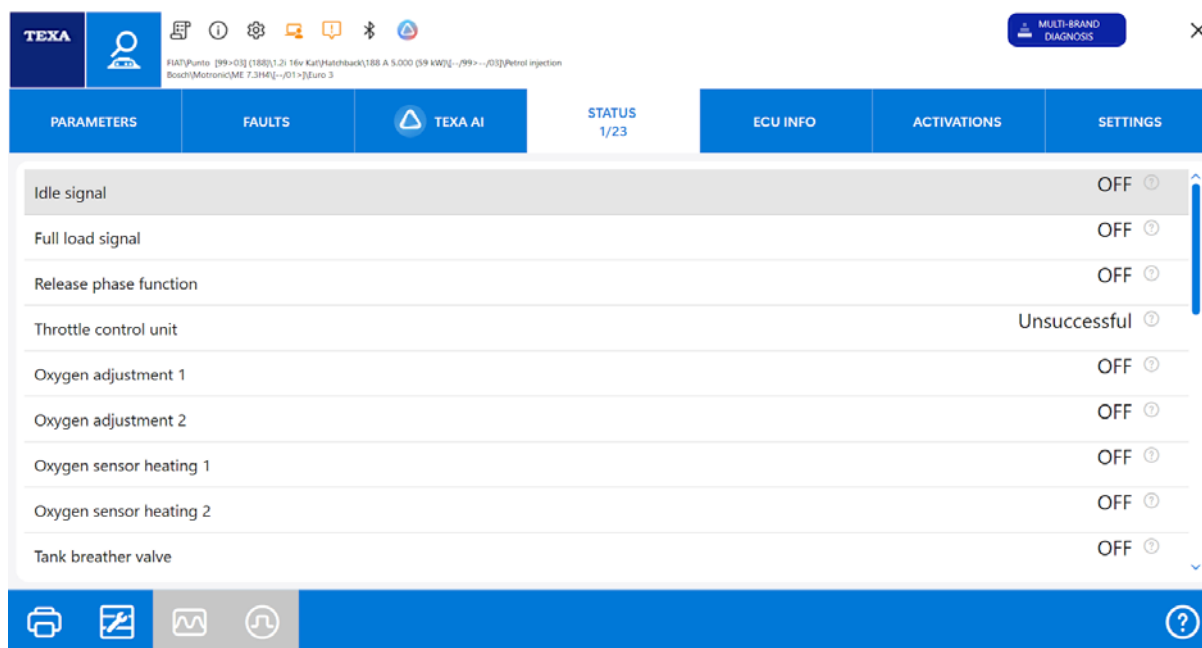
1. Press:**STATUSES**
2. Follow the instructions that appear on screen.



Icon	Name	Description
	Print	It allows you to print a report containing the statuses.
	Technical Documentation	It allows you to view the documentation regarding the diagnosis being carried out.
	Information	It allows displaying a help screen related to the selected status.

This screen provides the following information:

- **Description:** *description of the parameter.*
- **Status:** *it indicates the status of the parameter.*

19.5 ECU Information



In this page you can view information related to the control unit you are connected to and identify it correctly.

The function is particularly useful when a control unit has been replaced and must be configured.

Proceed as follows:

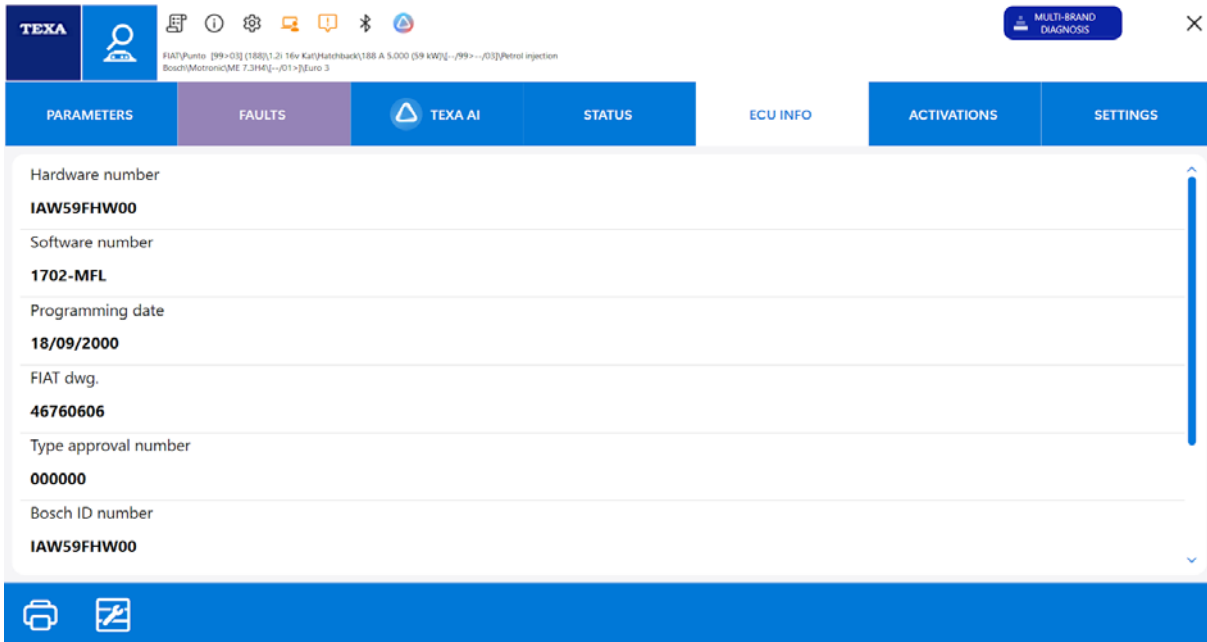
1. Press: **ECU INFO**



Icon	Name	Description
	Print	It allows printing or saving a report related to the detected errors.
	Technical Documentation	It allows you to view the documentation regarding the diagnosis being carried out.

19.6 Activations

In this page you can test the operation of specific actuators (components piloted by the control unit) by activating them temporarily.





This way you can verify the efficiency of the actuator and of the communication with the control unit.

In some systems the duration of test can be set by the operator, whereas in other systems it is established by the control unit's manufacturer.

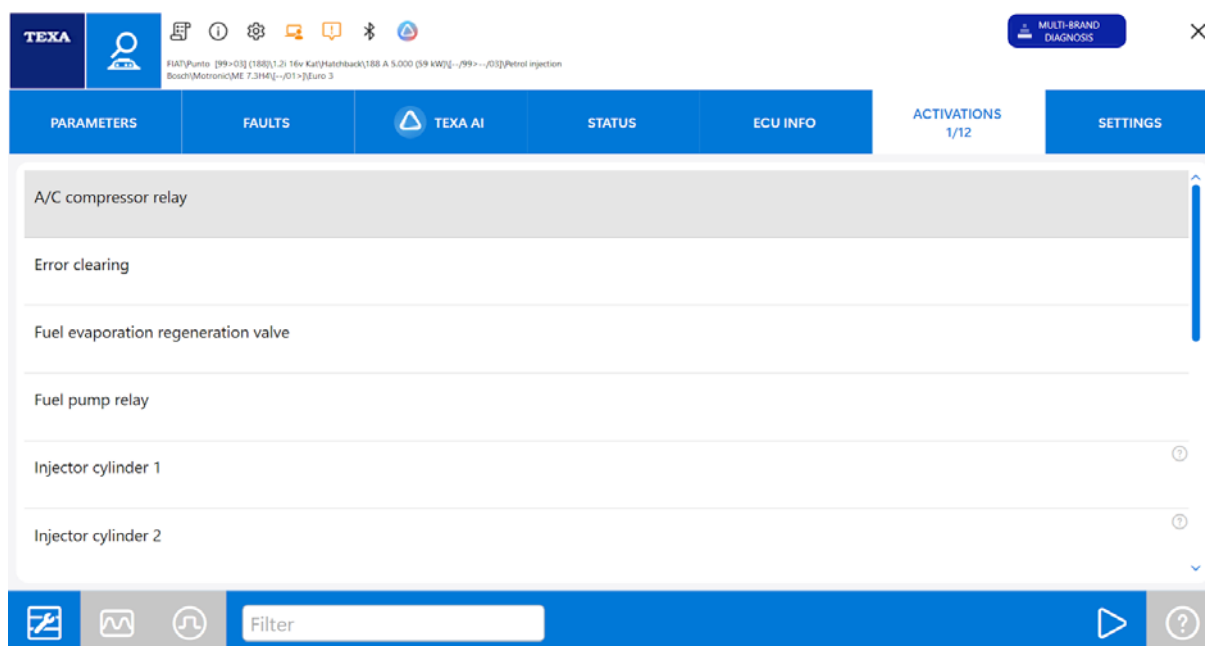
Proceed as follows:

1. Press:ACTIVATIONS



Icon	Name	Description
	Technical Documentation	It allows you to view the documentation regarding the diagnosis being carried out.
	Oscilloscope	It allows displaying graphically the trend of an electric signal over time.
	Signal generator	It allows you to simulate the input and output signals of the electronic control units used in vehicles.
	Activate	It allows carrying out the activation.
	Information	It allows displaying a help screen related to the selected activation.

INFORMATION

For further information see the Parameters chapter.

2. Select the desired activation.

3. Press: 

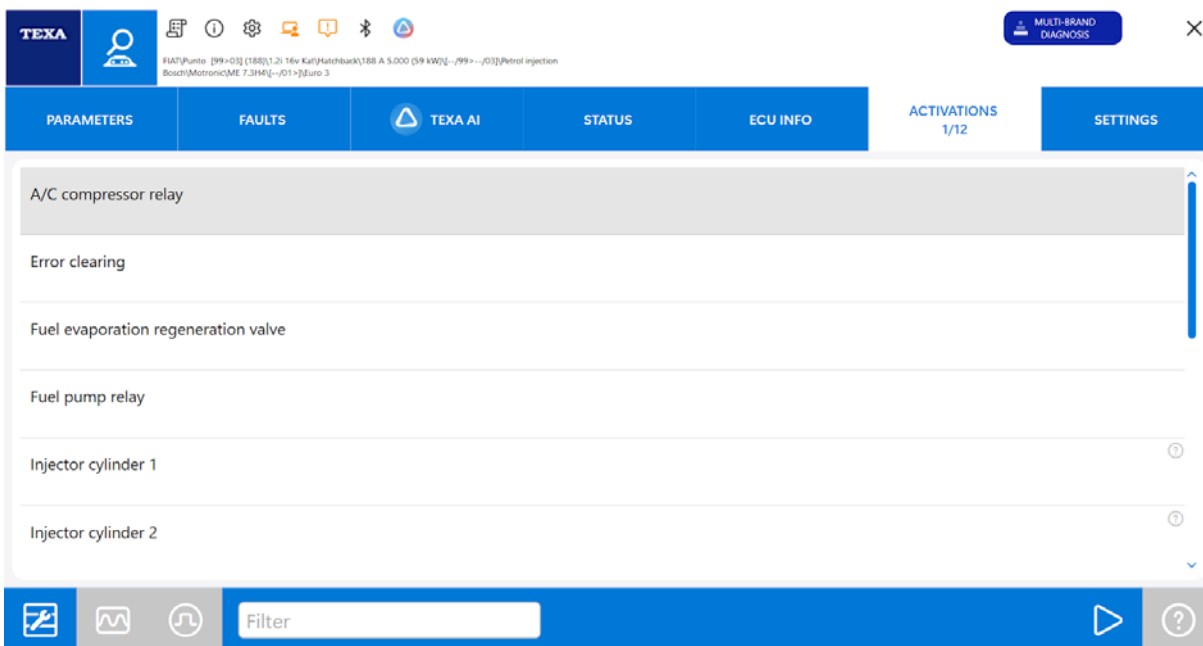

4. Follow the instructions on the screen.

5. Press: **CONFIRM**

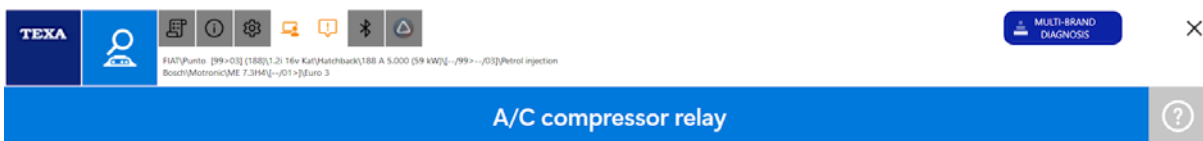

A/C compressor relay
UP/DOWN arrow to turn ON/OFF, CONFIRM or CANCEL to end

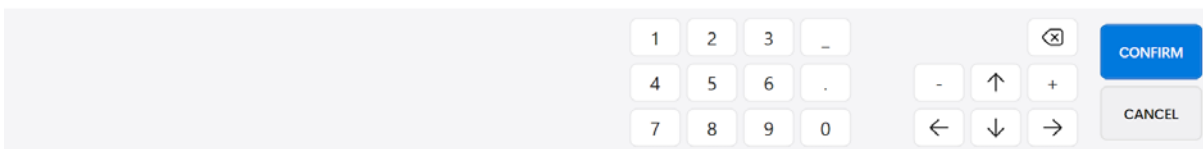

The device has been activated.

19.7 Adjustments

In this page you can perform permanent adjustments on specific electronic components.

You can do so through the functions that are provided by the control unit (ex.: idle speed adjustment, reset of the self-adaptive parameters, etc.).



INFORMATION

Adjustments on components are operations that must be treated carefully; for this reason, in certain cases, use of the software is limited by the request for a Special Code Web.

Proceed as follows:

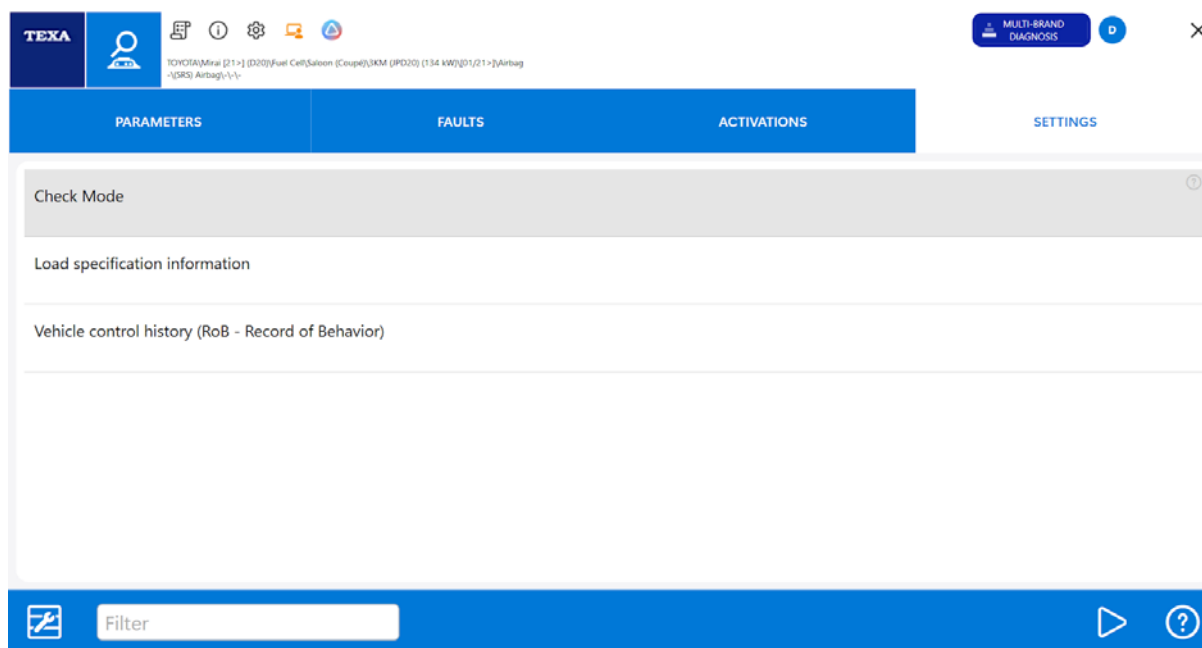
1. Press:ADJUSTMENTS



Icon	Name	Description
	Technical Documentation	It allows you to view the documentation regarding the diagnosis being carried out.
	Adjust	It allows you to carry out the selected adjustment.
	Information	It allows displaying a help screen related to the selected setting.

INFORMATION

For further information see the Parameters chapter.

2. Select the desired setting.

3. Press: 

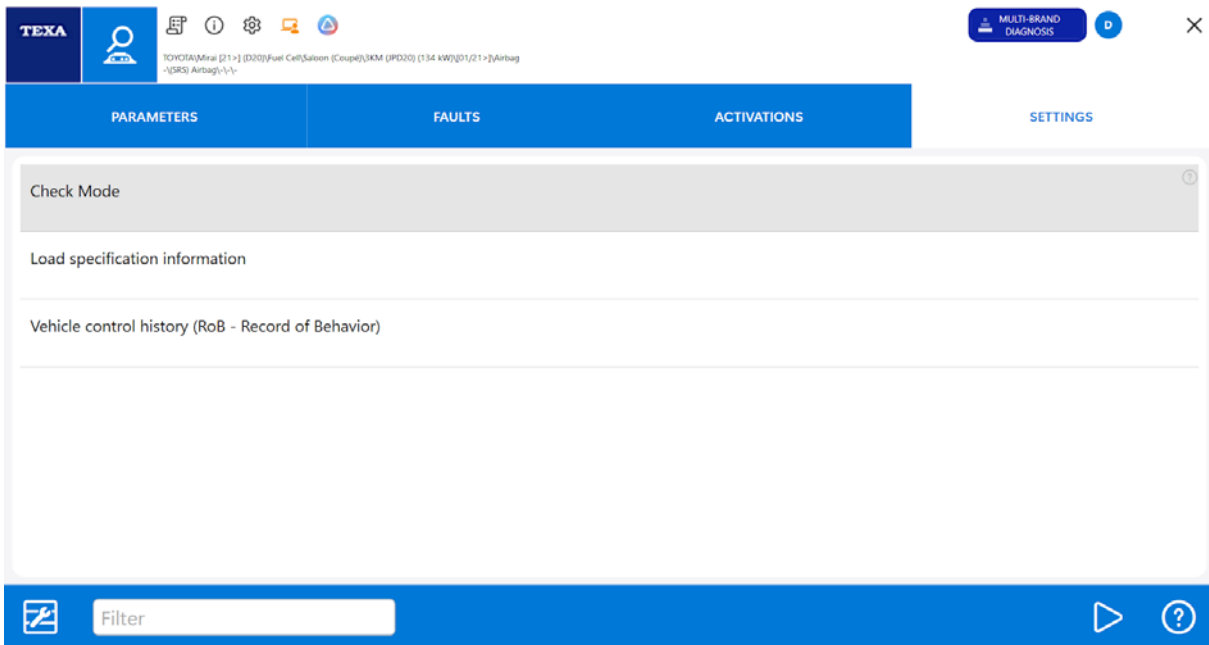

4. Follow the instructions on the screen.

5. Press: **CONFIRM**

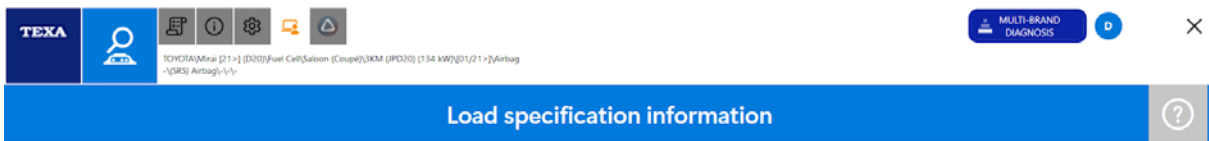

After replacing an ECU this utility will load the necessary specification information
Conditions required: ignition on (engine off/"Ready" indication off)
Press CONFIRM to continue or CANCEL to exit

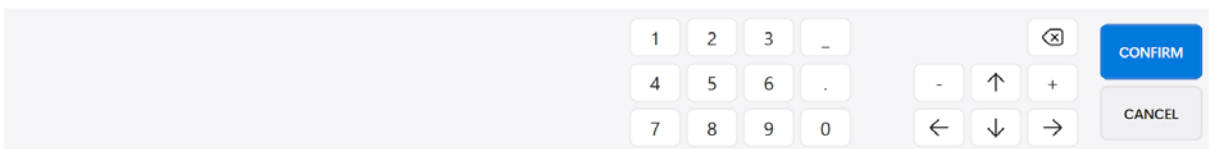

The adjustment has been carried out.

19.7.1 Special Settings

The software contains some **Special Settings** that require complete and detailed knowledge of the systems they affect.

These settings are protected by a specific code, called **Special Code Web**.

INFORMATION

Based on the environment you are working on, if there is no active Internet connection, the Special Settings may not be available or the number of operations that can be carried out on them may be limited.

Proceed as follows:

1. Press:ADJUSTMENTS

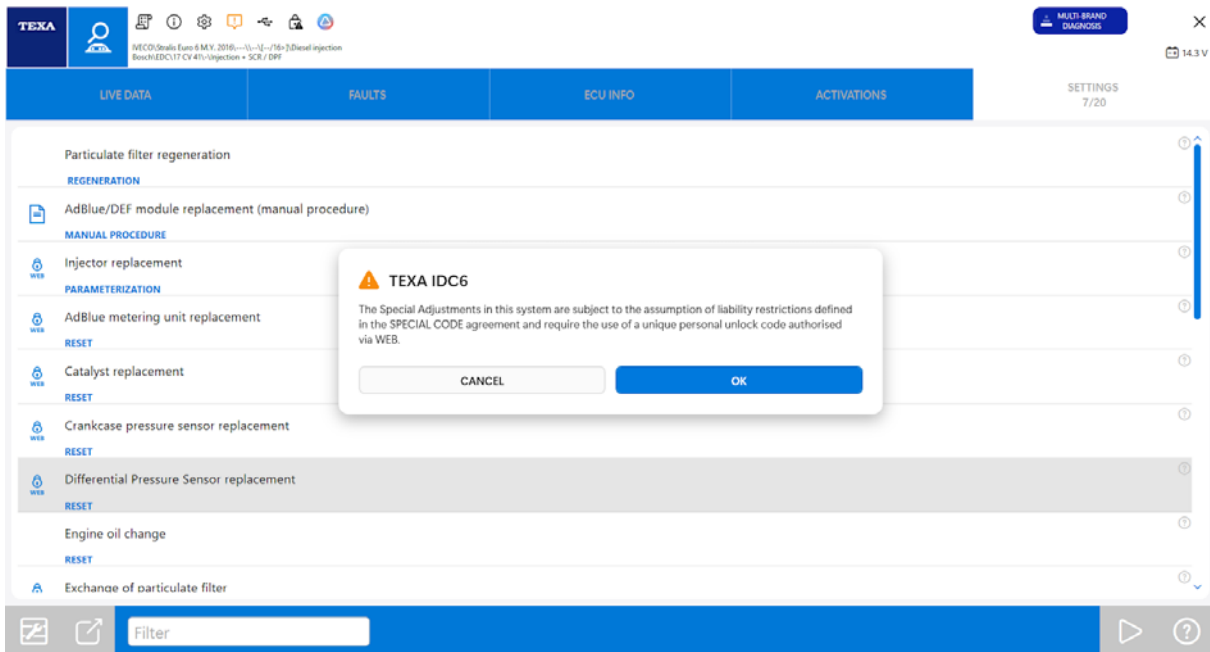

If there are any special settings, the software shows a specific message.

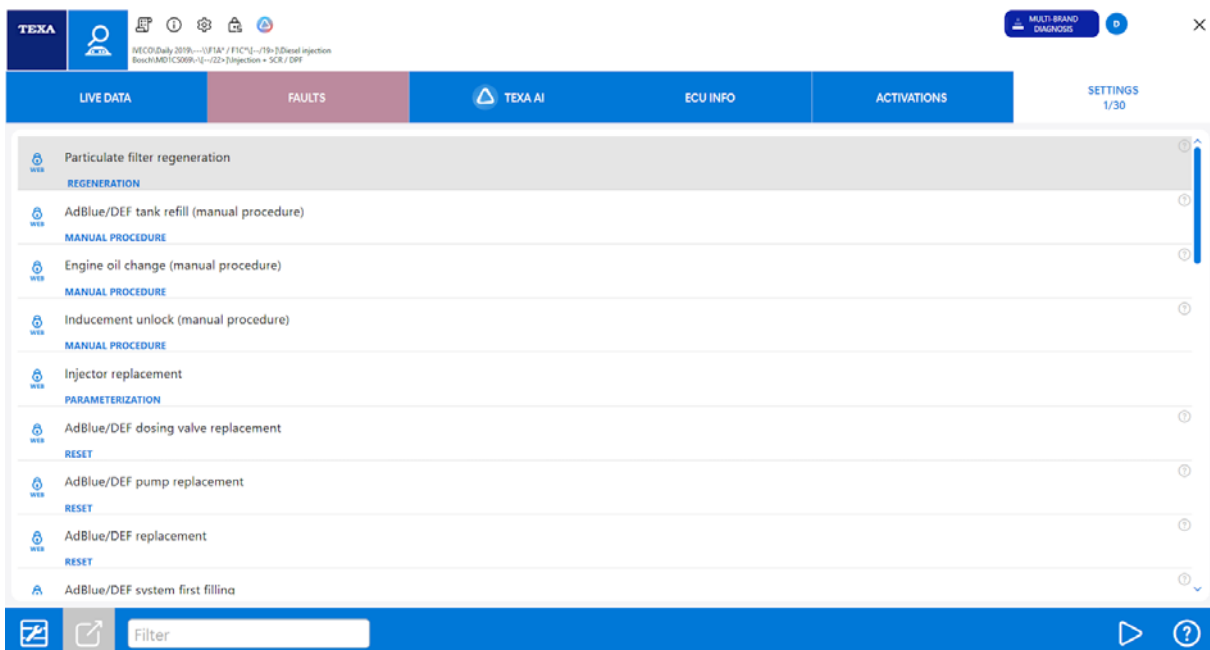

2. Press:OK



The protected settings are marked by a specific icon, whose colour indicates the setting status:

Icon	Status	Description
	Locked	The adjustment cannot be performed.
	OEM Locked	<p>The adjustment cannot be performed. It is a special type of adjustment, called "Advanced Special (OEM adjustments)".</p> <p>These adjustments are extremely sensitive and therefore disabled by default.</p> <p>To enable the adjustment, you need to ask your distributor for a specific form that must be filled in and sent to TEXA.</p>
	Unlocked	The adjustment can be performed.

- Proceed with the adjustment as described in the previous chapter.
The **Special Code Web** unlocks the setting while it is being used.

19.8 Print

This function allows printing or exporting the report in a PDF or XML format.

Proceed as follows:



1. Press:
2. Select the desired operation among:
 - *print*;
 - *add printing document to PDF file*;
 - *save printing data in XML file*.
3. Follow the instructions that appear on screen.

By exporting in PDF format, a single file is generated and the exportations queue until a new vehicle is selected.

By exporting in XML format, as many files as exportations are generated.

20 TECHNICAL DATA AND CHECKS



This function allows obtaining information related to:

- *vehicle maintenance;*
- *vehicle repair;*
- *technical drawings;*
- *assistance procedures;*
- *technical bulletins;*
- *recalls.*



Proceed as follows:

1. Carry out a complete selection.

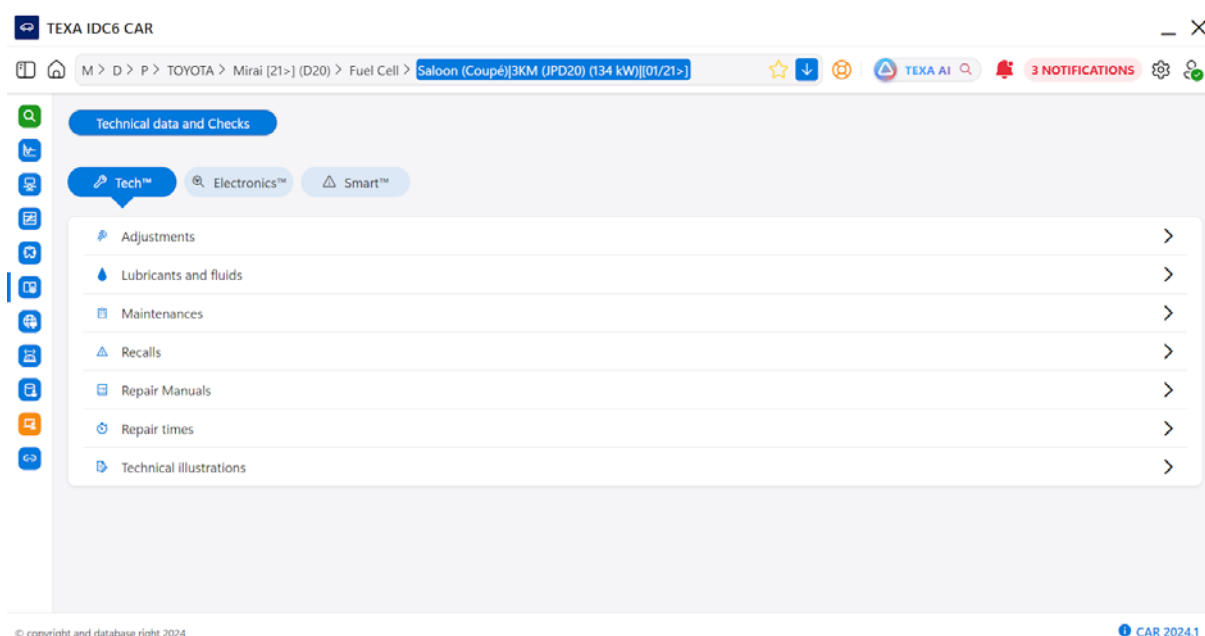
2. Press: 



This screen is divided in the sections:

Icon	Name	Description
	Tech™	It provides information related to the repair and maintenance of a vehicle.
	Electronics™	It allows retrieving the vehicle's CAN-BUS system data and diagnosing the faults and malfunctions that generate alarm codes; it also provides the location of the fuses and relays.
	Smart™	It allows immediate access to the Technical Bulletins and to the Recalls provided by the vehicle manufacturers.

INFORMATION

The list of the functions available in each section depends on the selection made and on the subscription purchased.

INFORMATION

Based on the selected item, free search fields and/or filter for the contents may be available.

en





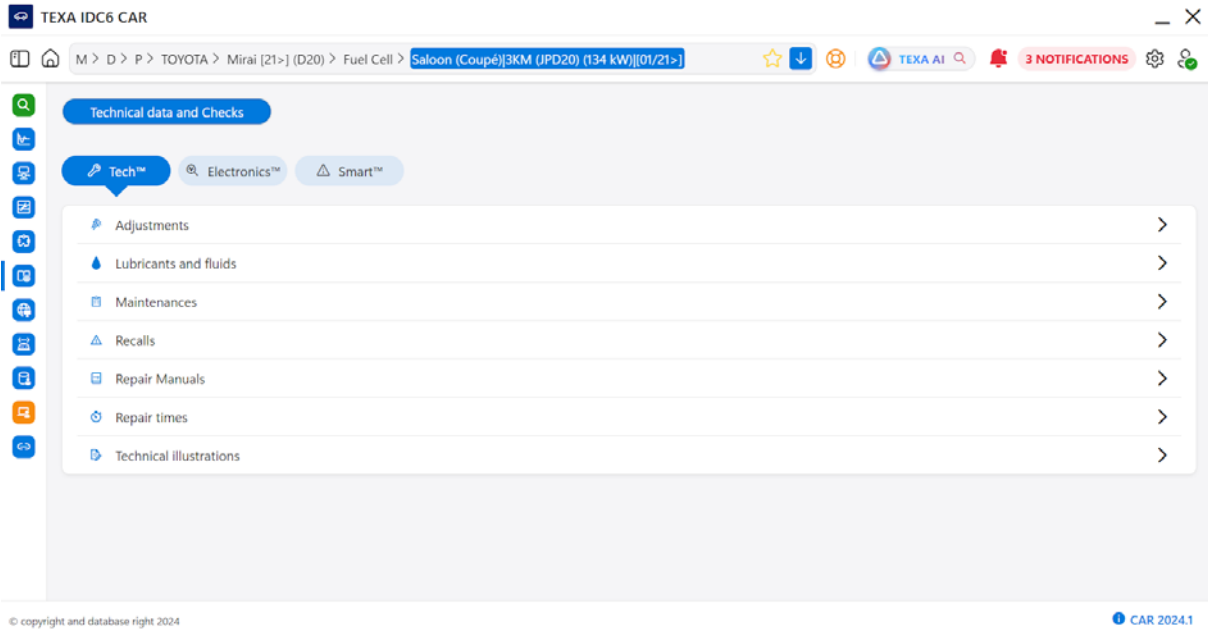

20.1 Tech™

This section provides information related to the identification, repair and maintenance of a vehicle. Proceed as follows:

1. Press: 



The information regarding the following is available:

Icon	Name	Description
	Technical Illustrations	It allows displaying one or more technical drawings in order to identify the components easier. It also allows selecting the spare parts to purchase and add to the work order.
	Lubricants and Fluids	It provides indications and technical features of the lubricants and fluids used and/or to use in the selected vehicle.
	Maintenances	It provides the minimum maintenance requirements established by the vehicle manufacturers.
	Adjustments	It provides indications on the settings of the analysed system, such as: <ul style="list-style-type: none"> • <i>torque setting;</i> • <i>cylinder firing;</i> • <i>minimum emissions;</i> • <i>brake disc thickness.</i>
	Repair times	It provides the indicative repair times to calculate the maintenance and/or repair estimates.
	Recalls	It provides official recall data by the vehicle manufacturers.

- Select the desired item.(ex.: Technical Illustrations)
The first available technical sheet is displayed.

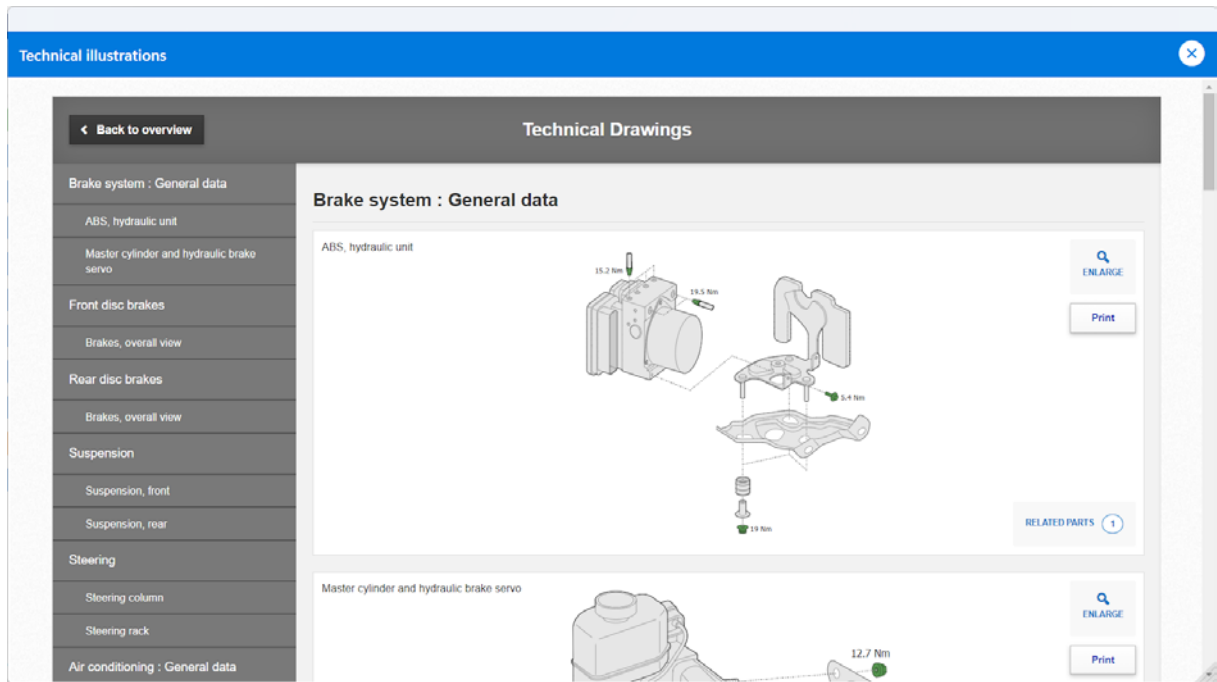

- Select the desired item. (ex.: Front disc brakes)
The chosen sheet is displayed.

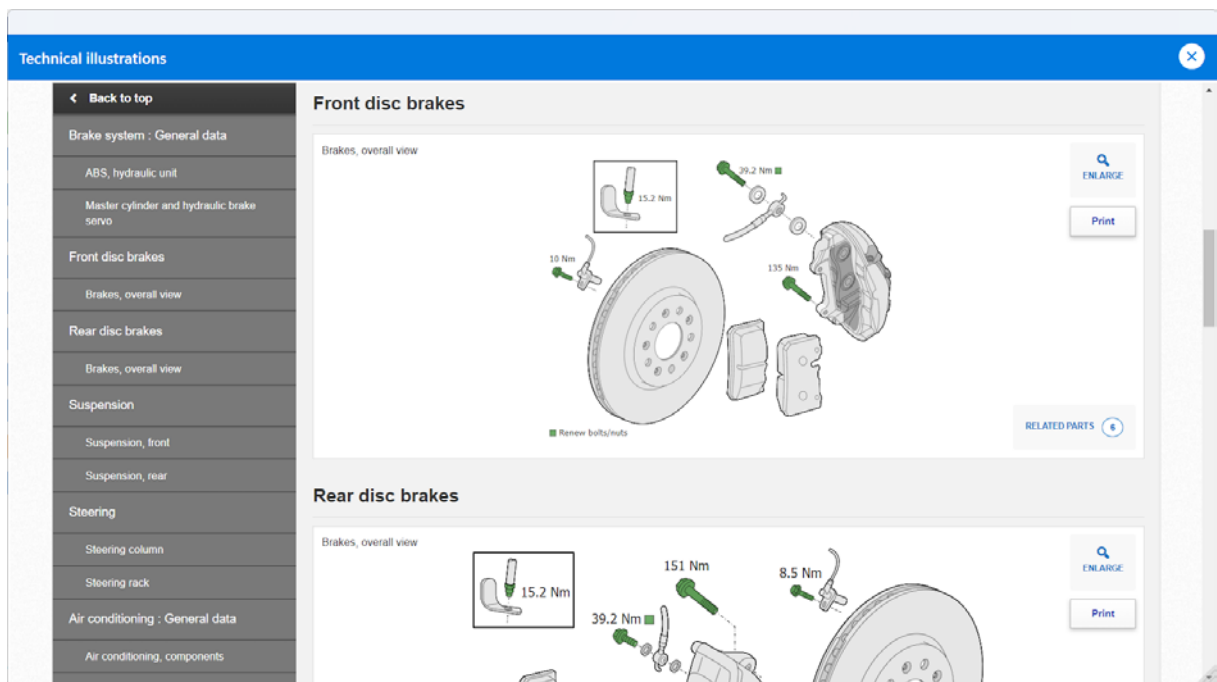

INFORMATION

Based on the selected item, free search fields and/or filter for the contents may be available.

20.2 Electronics™



This section allows recovering the vehicle's CAN-BUS system data and diagnosing the faults and errors generated by the fault codes.

Proceed as follows:

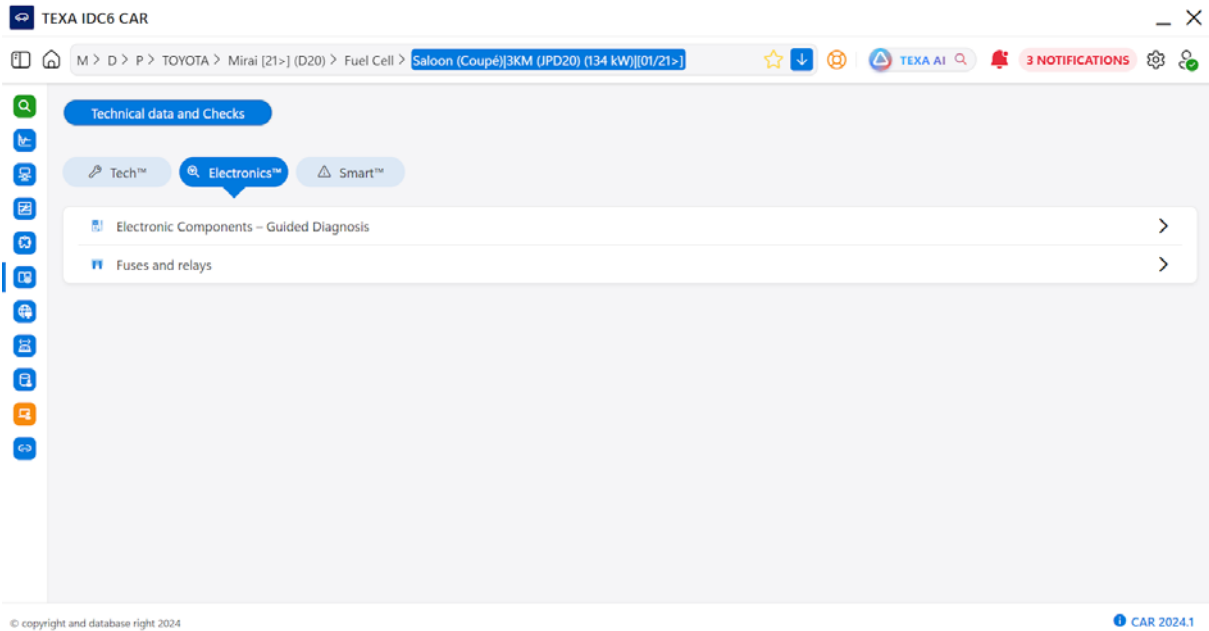
1. Press: 



The information regarding the following is available:

Icon	Name	Description
	Electronic components – Guided Diagnosis	It allows consulting the guided instructions on the electronic components to work on vehicles safely.
	Fuses and Relays	It provides information on the position of the electronic components and indications and explanations on the warning lights.

INFORMATION

Based on the selected item, free search fields and/or filter for the contents may be available.

2. Use the available functions (filters, free search, etc.) to search for and select the desired information.

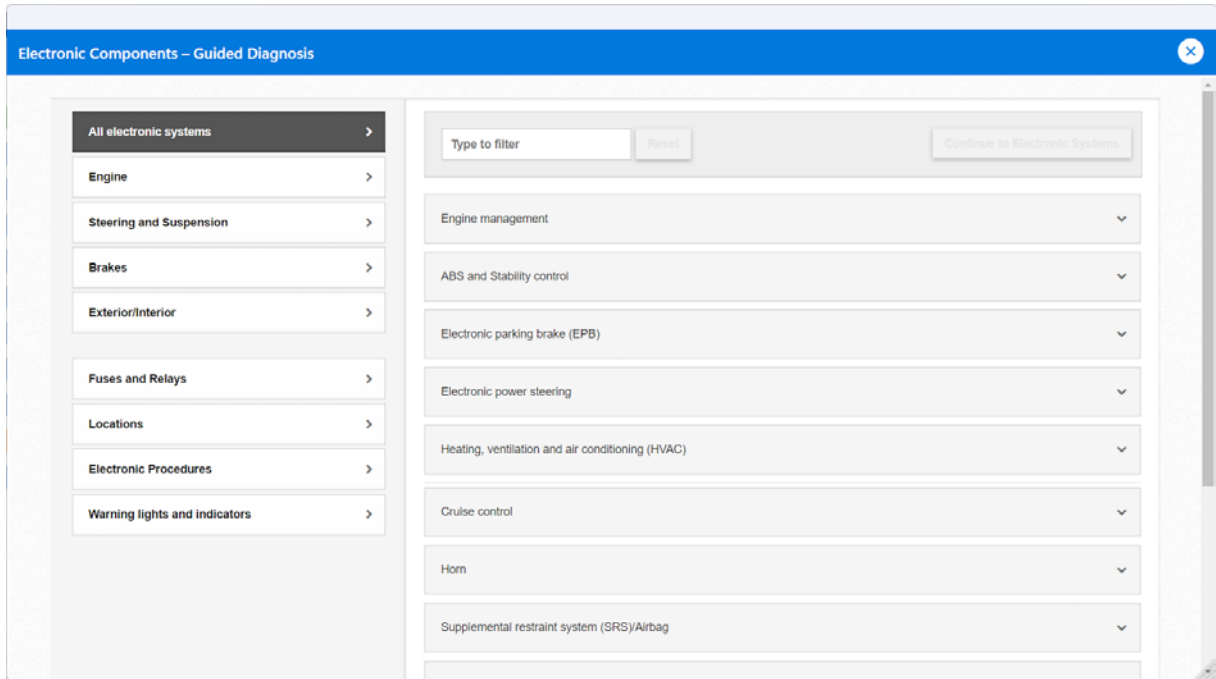

The information is displayed.

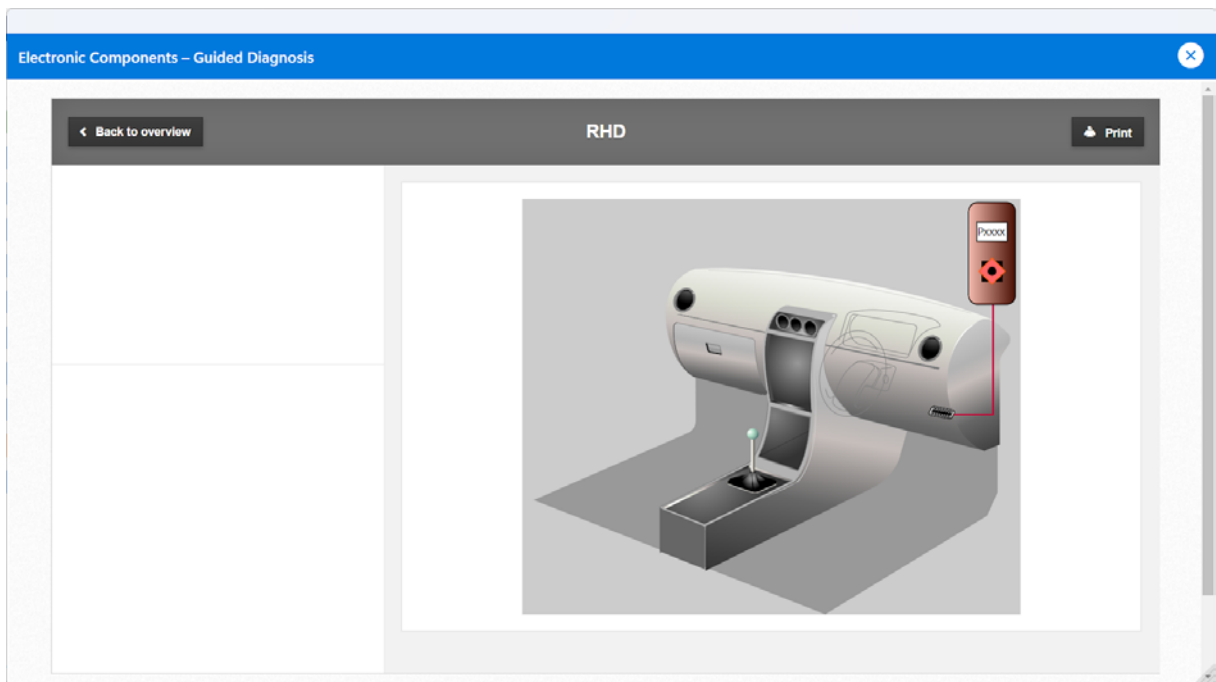

20.3 Smart™



This module allows immediate access to the Technical Bulletins and to the Recalls provided by the vehicle manufacturers.

Proceed as follows:

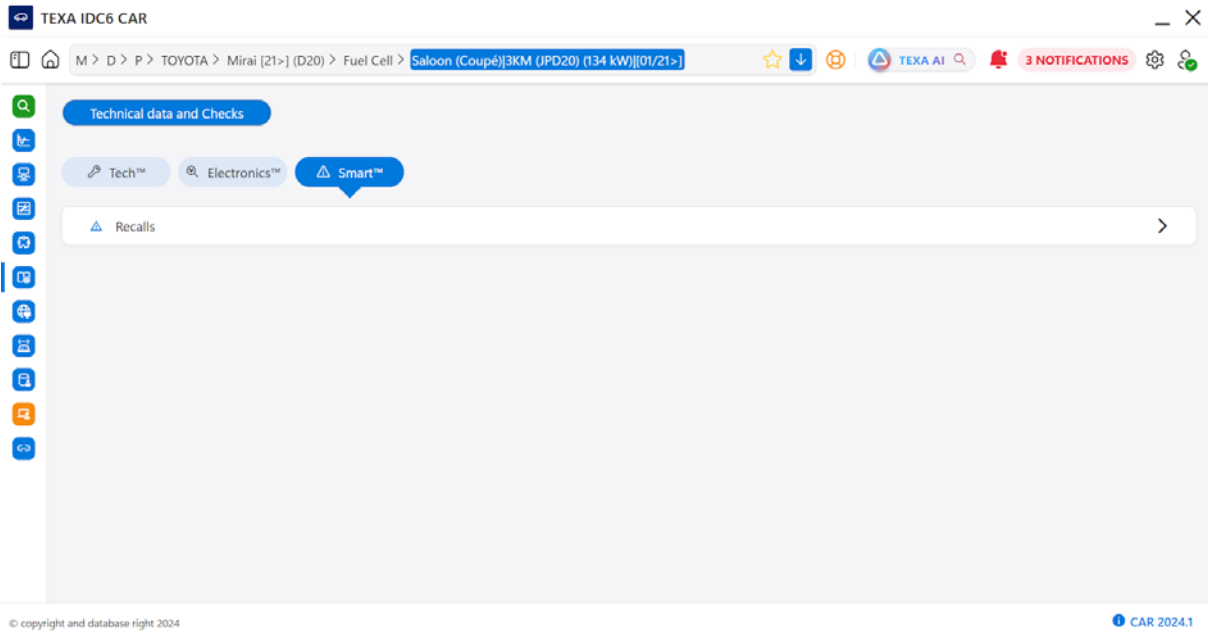
1. Press: 



The information regarding the following is available:

Icon	Name	Description
	Recalls	It provides official recall data by the vehicle manufacturers.
	Technical Bulletins	It provides the Technical Bulletins released by the vehicle manufacturers.
	Solved problems	It allows quickly checking the solutions to common problems related to a selected vehicle that may or may not be connected with a fault code.

INFORMATION

Based on the selected item, free search fields and/or filter for the contents may be available.

2. Use the available functions (filters, free search, etc.) to search for and select the desired information.

The screenshot shows the 'Recalls' search interface. At the top, there is a blue header with the title 'Recalls' and a close button. Below the header, the 'SmartPACK™' logo is displayed. The main area contains a search filter section with a 'Filter results' label. It includes a text input field for 'Type to search', a 'Reset' button, and a 'Sort results' dropdown menu set to 'Most recent date first'. Below the search fields are three dropdown menus for 'Vehicle area', 'Fault code', and 'Defect'. A navigation bar shows filters for 'All' (1), 'SmartCASE™' (0), 'Recall data' (1), and 'Technical Service Bulletins' (0). The 'Recall data' section is active, displaying a single result: '(Programming fault) The data communication module (DCM) may fail to complete the shutdown process; (- 04/08/2023)'. A footer contains a disclaimer: 'All trademark names mentioned herein are for reference purpose only and are not intended to suggest any connection between HaynesPro and such companies. All trademarks are the property of their respective owners. Version: 24.5.1-RD.'

The information is displayed.

The screenshot shows the detailed view of a recall. At the top, there is a blue header with the title 'Recalls' and a close button. Below the header, there is a dark grey bar with a 'Back to overview' button on the left, the recall title '(Programming fault) The data communication module (DCM) may fail to complete the shutdown process; (- 04/08/2023)' in the center, and a 'Print' button on the right. Below this bar, the recall ID '.../.../2023 A12/02415/23 (23SD-101)' is shown on the left and the date 'Date 2023-08-04' on the right. The main content area is divided into two sections: 'Defect' and 'Solution'. The 'Defect' section contains the text 'The emergency services will not be contacted following a crash'. The 'Solution' section contains the text 'Contact the manufacturer's authorised representative. The manufacturer will arrange the necessary checks and repairs'. A footer contains a disclaimer: 'All trademark names mentioned herein are for reference purpose only and are not intended to suggest any connection between HaynesPro and such companies. All trademarks are the property of their respective owners. Version: 24.5.1-RD.'

21 DASHBOARD



This function allows viewing a graphical representation of the vehicle that is useful for the diagnostic operations.

21.1 Parameters (Diagnosis)

The function can be started manually from the Parameters page during the diagnosis.

In this mode the function displays a graphical representation of the read parameters related to the vehicle being diagnosed.

INFORMATION

The function may only be available for some systems in the selected vehicle.

Proceed as follows:

1. Press: 

The vehicle's graphical representation is displayed.

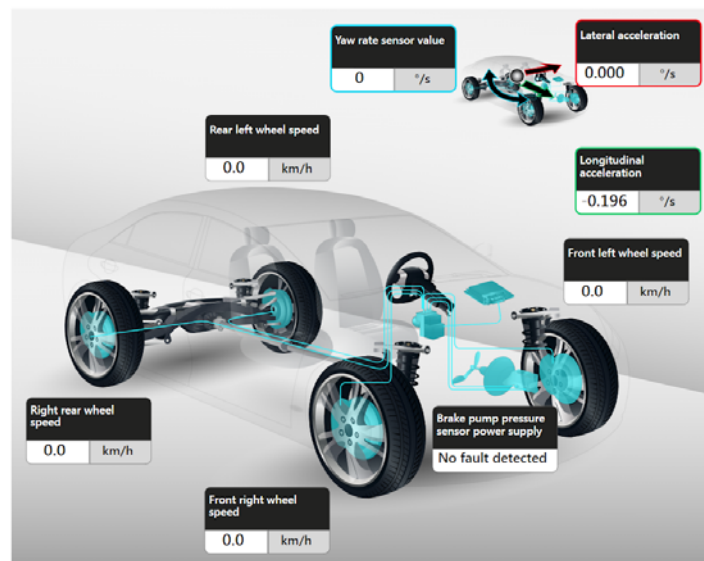

1/1



INFORMATION

It may be displayed in more than one page.

The view varies based on the selected system.

21.2 TGS3s

The function can be started manually at the end of the scan performed via TGS3. In this mode, the function displays a graphical representation of the scan result. Proceed as follows:

1. Press: 

The graphical representation of the scan result is displayed.

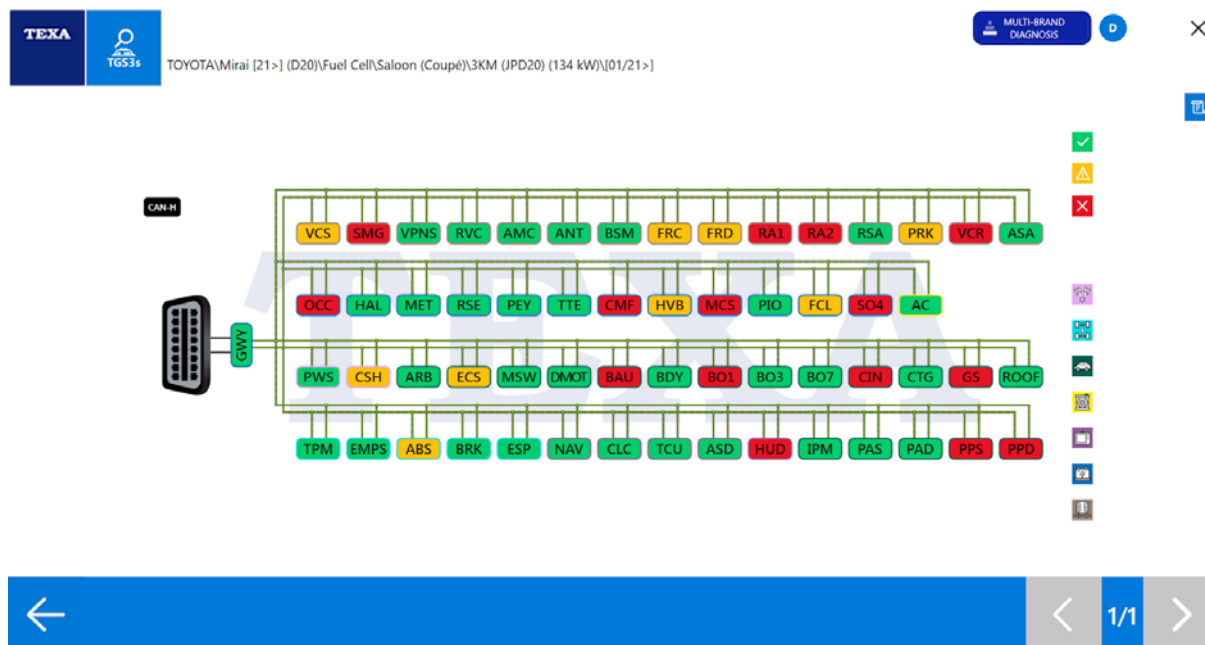

With an icon the software indicates the detected communication protocols (ex.: CAN-H).

By pressing on a protocol icon, the software graphically highlights which systems communicate with each other through the selected protocol.

The colour with which each system is highlighted indicates:

Icon	Description
Green	The system was detected and there are not any errors.
Yellow	The system was detected and there is at least one error.
Red	The system was not detected. It is possible that the model you are working on does not have the system at issue or that the system is not responding correctly to the request.

The software gathers the various systems by subject areas.

An icon located on the right side of the screen is associated with each subject area.

By pressing on a subject area icon, the software graphically highlights which systems are in it.

DISPLAY OF LEGEND OF CODES USED

You can view a legend with the specific code conferred to each system.

Proceed as follows:

1. Press: 

The legend is displayed.

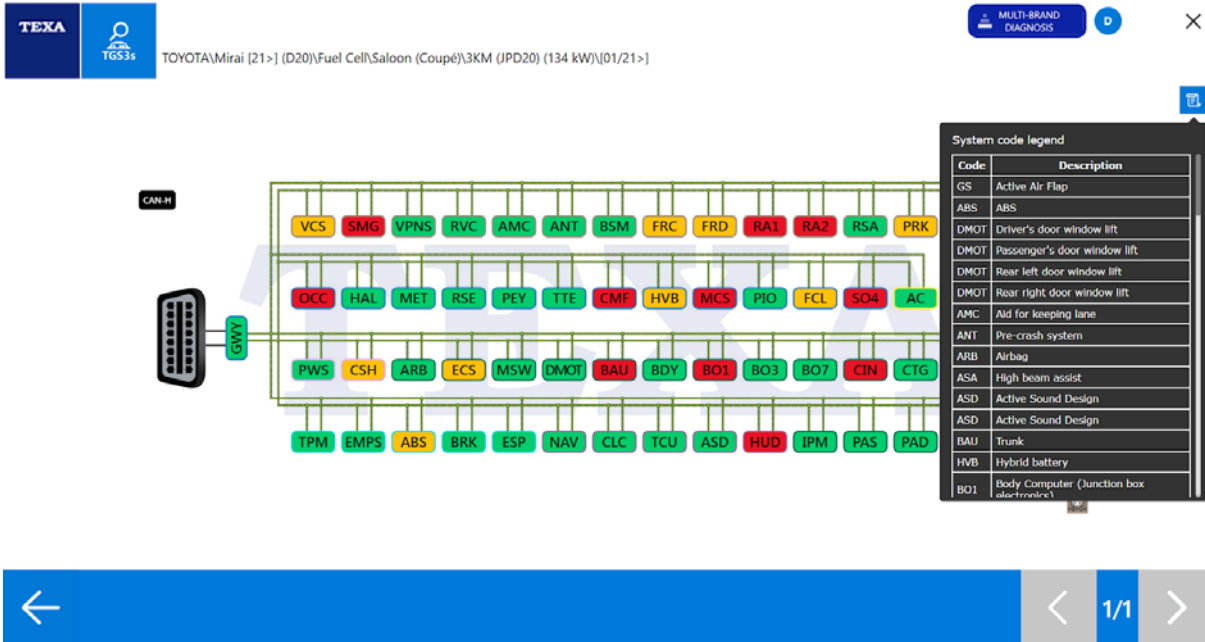

TOYOTA\Mirai [21>] (D20)\Fuel Cell\Saloon (Coupe)\3KM (JPD20) (134 kW)\01\21>

System code legend

Code	Description
GS	Active Air Flap
ABS	ABS
DMOT	Driver's door window lift
DMOT	Passenger's door window lift
DMOT	Rear left door window lift
DMOT	Rear right door window lift
AMC	Aid for keeping lane
ANT	Pre-crash system
ARB	Airbag
ASA	High beam assist
ASD	Active Sound Design
ASD	Active Sound Design
BAU	Trunk
HVB	Hybrid battery
BO1	Body Computer (Junction box electronics)

Navigation: < 1/1 >

STARTING THE DIAGNOSIS ON THE SELECTED SYSTEM

You can view the errors detected on a system and start their diagnosis directly.

Proceed as follows:

1. Press on the desired system.

The list of detected errors is displayed.

TOYOTA\Mirai [21->] (D20)\Fuel Cell\Saloon (Coupé)\3KM (JPD20) (134 kW)\[01/21->]

Parking help

Faults: 2

- C1AE0 96 Front left side sensor
- U0293 87 Lost Communication With Hybrid Powertrain Control Module

DIAGNOSIS

1 / 2

1 / 1

2. Press:



22 TECHNICAL DOCUMENTS

This function allows you to view various types of technical documentation, such as:

- *Vehicle Sheets;*
- *Self-diagnosis Sheets;*
- *System Sheets;*
- *Wiring Diagrams.*

You can find these documents through the corresponding functions during the vehicle selection.

INFORMATION

The type and number of documents displayed varies based on the selection performed.

Proceed as follows:



1. Press:

2. Select Vehicle Sheets.

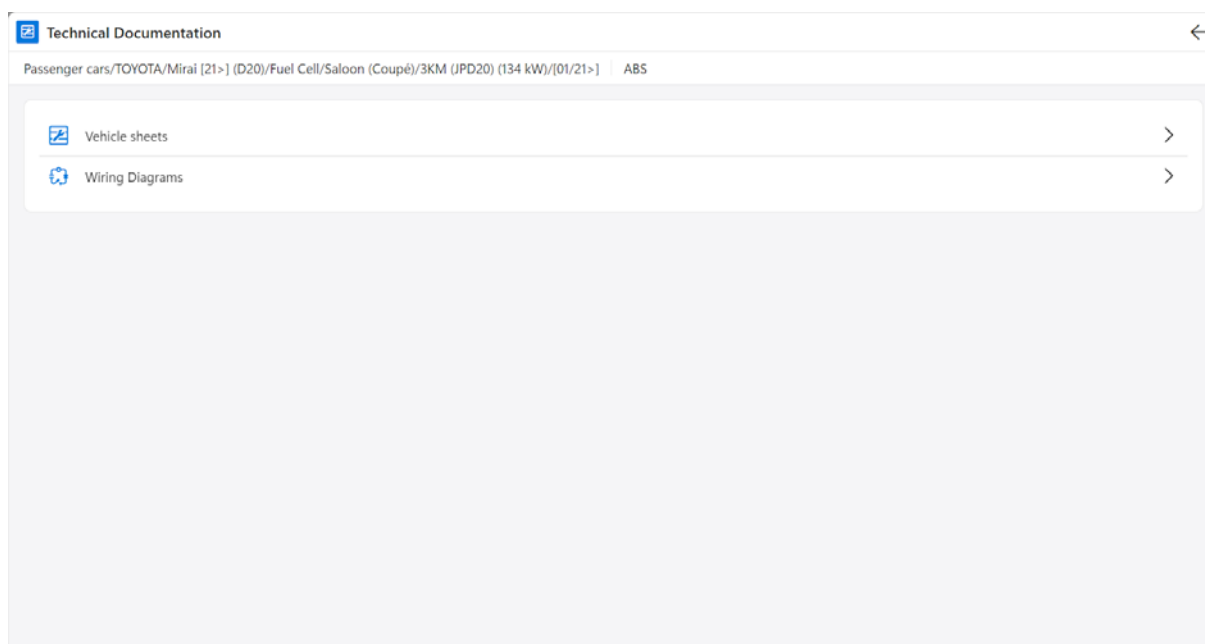

3. Select the desired document to view it.

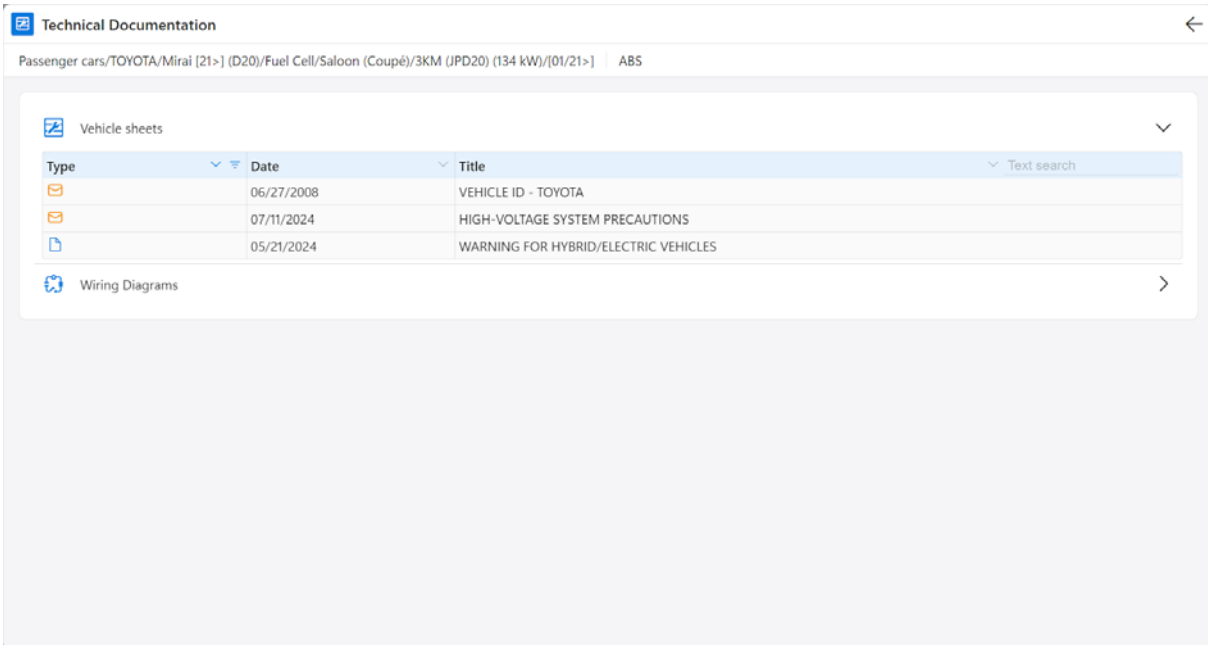

The document is displayed.

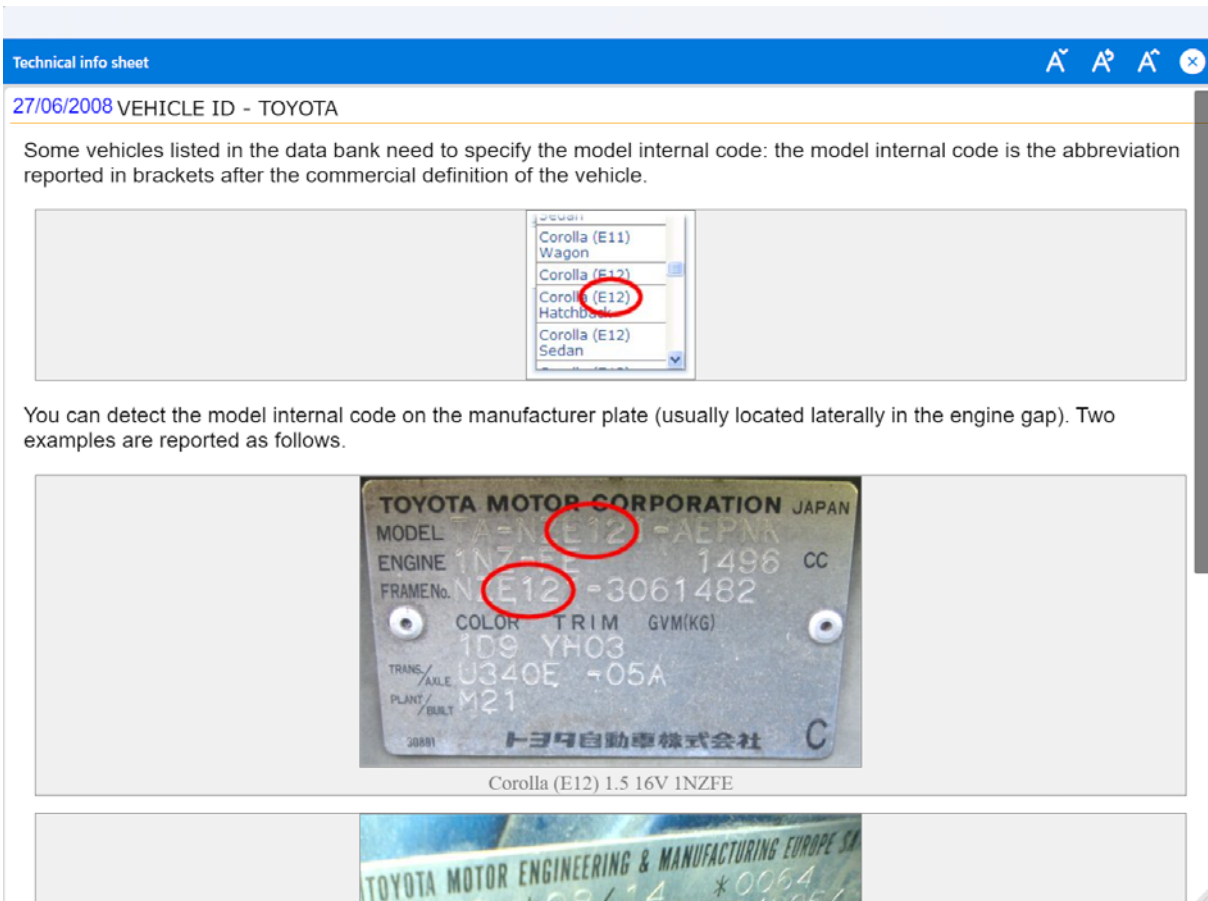

INFORMATION

For further information see the corresponding chapters.

23 ALIGNMENT CHECK



This section allows checking the vehicle alignment.

Proceed as follows:

1. Carry out a complete selection.
2. Press:

A technical sheet is displayed to help with the positioning of the devices required for the check.

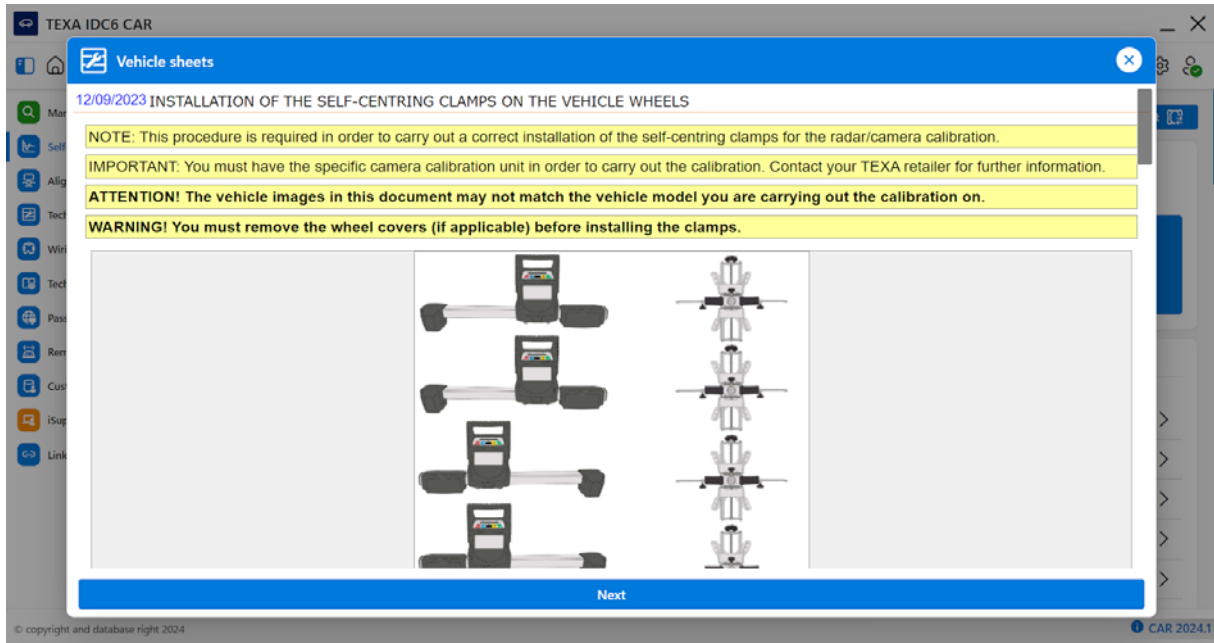

3. Press: **NEXT**
4. Select the diameter of the vehicle's rims in inches.

5. Press: **Continue**

6. A technical sheet is displayed to help with the check.

TEXA IDC6 CAR

Vehicle sheets

12/09/2023 INSTALLATION OF THE MEASURING HEADS AND VEHICLE TOE AND THRUST AXIS CHECK

Requirements for the check:

- The vehicle must be parked on a flat surface;
- Check and eventually correct the pressure in the tyres to the value specified by the manufacturer;
- The boot and the passenger compartment must be empty (vehicle unloaded);
- No gear engaged (neutral for a manual transmission, N for an automatic transmission);
- Parking brake disengaged;
- The steering wheel must be in a central position and the wheels must be straight;

NOTE: To make sure the steering wheel is in a central position, in the diagnosis of the power steering control unit (or steering angle sensor/ABS control unit) check the value of the parameter related to the steering angle: the displayed value must be 0° and **must be obtained with the vehicle unloaded (nobody inside)**.

1) During the first check phase, the **NOMINAL (green box)** values and the related **TOLERANCES (yellow boxes)** are displayed for the diagnosed vehicle;

ATTENTION! These values are **NOMINAL**, the **ACTUAL** data related to the toe and thrust axis of the diagnosed vehicle are displayed after following the software's indications.

Convergenza	Gr.	0.00	0.00	0.00	0.00
Indiventa ant.	Gr.	0.00	0.00	0.00	0.00

Next

© copyright and database right 2024 CAR 2024.1

7. Press:**NEXT**

A guided procedure is started.

8. Follow the instructions that appear on screen.

24 GUIDED DIAGNOSIS



This function allows displaying the step-by-step guided instructions for the maintenance, repair and troubleshooting of the selected vehicle.

INFORMATION

The function can be accessed from various points in the software.

Proceed as follows:

1. Press: **Guided Diagnosis**
2. Select the desired error.

The screenshot shows the TEXA AI software interface. At the top, there's a header with the TEXA logo, a user profile icon, and several status indicators: 'AUTHENTICATED DIAGNOSIS', 'SUBSCRIBED USER', 'GATEWAY UNLOCKED', and a 'D' icon. Below the header, there's a navigation bar with 'PARAMETERS', 'FAULTS', 'TEXA AI', 'ECU INFO', and 'ACTIVATIONS'. The 'FAULTS' section is active, showing a list of errors. The first error is 'B1600 1C Control unit malfunction - Circuit voltage out of range'. Below this error, there's a button labeled 'Guided Diagnosis' which is highlighted in blue.

3. If necessary, select the exact vehicle model.

The screenshot shows the TEXA AI software interface with the 'Guided Diagnosis' button highlighted. Below the button, a list of vehicle models is displayed. The list includes the following information for each model:

Model	CM ³	KW	Production	Engine Code
ALFA ROMEO Giulia (952) 2.2 16V JTD	2143	118	2018-01/2022-12	[46335975]
ALFA ROMEO Giulia (952) 2.2 16V JTD	2143	118	2018-01/2022-12	[48335975]
ALFA ROMEO Giulia (952) 2.2 16V JTD	2143	140	2018-01/2022-12	[46335975]
ALFA ROMEO Giulia (952) 2.2 16V JTD	2143	140	2018-01/2022-12	[48335975]
ALFA ROMEO Giulia (952) 2.2 16V JTD	2143	100	2019-01/null	[46335975]

4. Select the desired information type among the proposed ones (e.g. Technical assistance bulletins).

Electronic Components – Guided Diagnosis

ALFA ROMEO Giulia (952) 2.2 16V JTD 2018 - 2022

Fault codes

Search one or more fault codes, separating them with a comma

Search

SmartPACK™

TSBs (Technical Service Bulletins)	16
Recalls	12
Cases	2

All trademark names mentioned herein are for reference purpose only and are not intended to suggest any connection between HaynesPro and such companies. All trademarks are the property of their respective owners.
Version: 24.4.3 R2

INFORMATION

You can carry out a specific search by entering one or more error codes in the specific field.

5. Select the desired guided diagnosis.

Electronic Components – Guided Diagnosis

SmartPACK™

Filter results

Type to search

Sort results: Most recent date first

Vehicle area Fault code Defect

All 30 SmartCASE™ 2 Recall data 12 **Technical Service Bulletins 16**

Technical Service Bulletins

- Software updates are required to improve control unit functionality
- Seat belt latching failure; A seat belt unlatched warning will illuminate in the instrument cluster
- The malfunction indicator light (MIL) illuminates; An AdBlue level warning message appears on the display; Incorrect AdBlue level reading; EURO 6d
- Unintended alarm system activation
- Inoperative drive mode selector switch (DNA) Standard suspension, 2020

6. Follow the instructions that appear on screen.

The screenshot displays a diagnostic software window titled "Electronic Components – Guided Diagnosis". The main heading is "Software updates are required to improve control unit functionality". A "Print" button is visible in the top right corner. Below the heading, the date and time "18/05/2023 55.024.23" are shown. The content is organized into three sections: "Symptom", "Cause", and "Solution".

Symptom
Control units requiring a software update to improve functionality:
Telematics control unit
The maintenance symbol will show on the display with the service message

Cause
Faulty telematics control unit software

Solution
Connect the diagnostic tool

Telematics control unit:
Check for any available software updates
If the software can be updated, proceed as follows:
Place the battery on charge
Ensure that all electrical consumers are switched off
Update the telematics control unit software

Read out the fault codes
Delete all the fault codes

25 REMOTE DIAGNOSIS



Remote diagnosis allows carrying out diagnoses remotely by connecting to the **TEXA** Call Center.

The remote diagnosis takes place by connecting the device to the vehicle's OBD socket and to the display unit with the **IDC6** software with the **Info Connect** function enabled installed in it.

The software, following a series of selections, opens a "direct communication" between an expert at the **TEXA** Call Center and the vehicle.

Thanks to this connection, the **TEXA** expert can help the operator complete diagnostic operations that are not yet available in the software update or that may be particularly complex and unusual compared to the activities the workshop normally carries out.

INFORMATION

This function is not available for all markets.



1. Press
2. Follow the instructions that appear on-screen.

25.1 INFO CONNECT

INFO Connect
✕

Informazioni di connessione servizio INFO Connect

1. Connettere lo strumento di diagnosi TEXA o il PC su cui è installato il software IDC5 alla rete internet.
2. Collegare INFO Connect alla porta USB dello strumento di diagnosi TEXA o del PC.
3. Collegare il connettore OBD di INFO Connect alla presa OBD del veicolo.
4. Viene avviata l'applicazione.

Nota:
Se l'applicazione non si avvia verificare di aver effettuato correttamente tutte le operazioni, scollegare e ricollegare INFO Connect alla presa OBD del veicolo e premere il tasto "Riavvio".

Quantità di TEXA Coin residua:
1200

Connessione USB

⚙️
Riavvio

INFORMATION

The remote diagnosis requires payment in TEXA Points.

For further information on the payment methods in TEXA Points contact your retailer.

3. Press

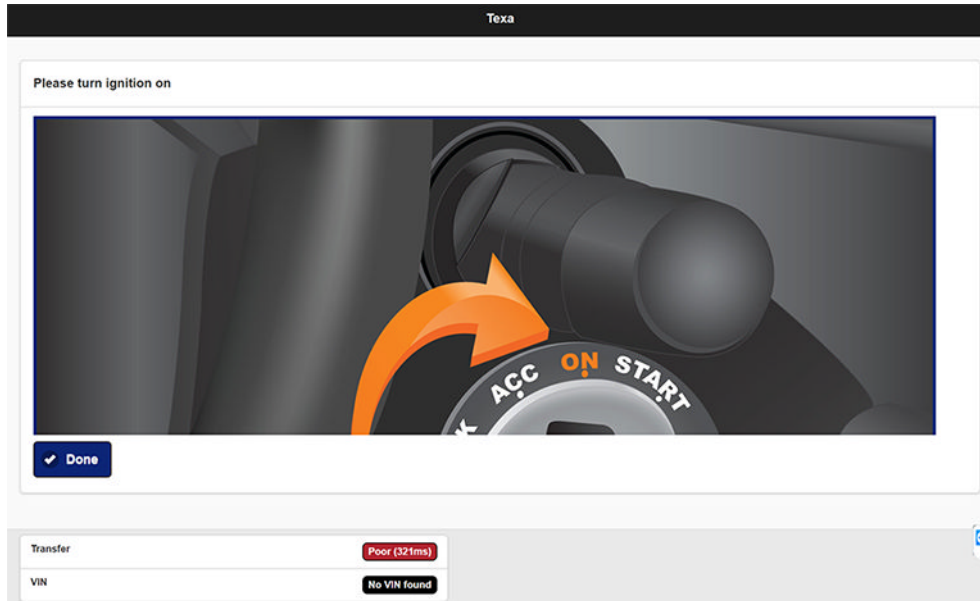

Select the vehicle you wish to diagnose by setting:

- *Make*
- *Model*
- *Type*
- *Engine type*

In order to go from one selection level to the next you must first complete the level you are currently in.

4. Press

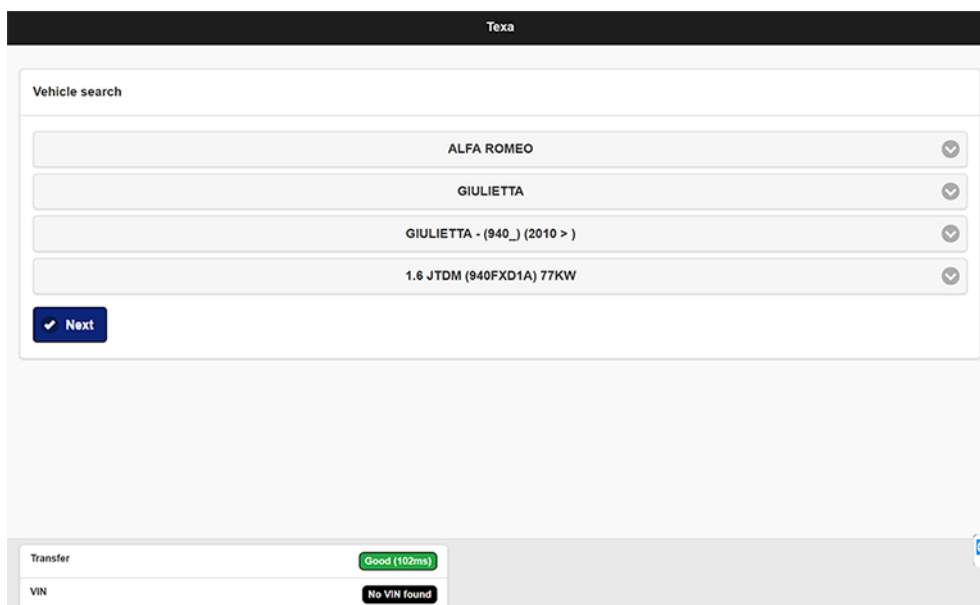

5. Enter the license plate number of the vehicle for which you are requesting the remote diagnosis.

INFORMATION

Entering the license plate number is optional and can be omitted, we however recommend it to be able to trace the operation.

6. Among the listed categories, select the operation you wish to carry out.

The list appears when the vehicle has been selected correctly.

INFORMATION

The operations that are available depend on the make and model of the vehicle selected.

7. Press



8. Check the operation selected and related cost.

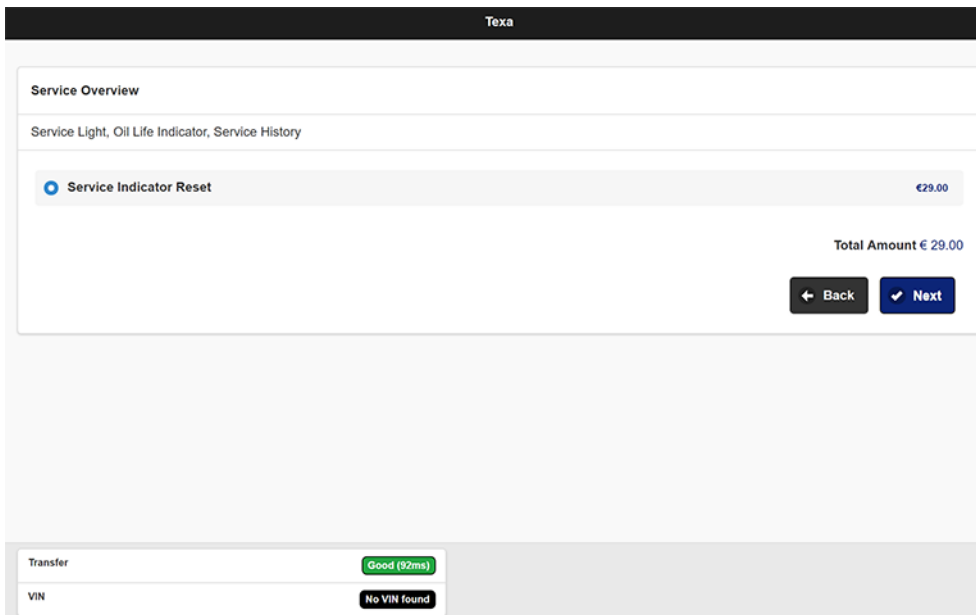

INFORMATION

The cost of the operation varies based on the intervention required.

9. Press



The summary screen is displayed.

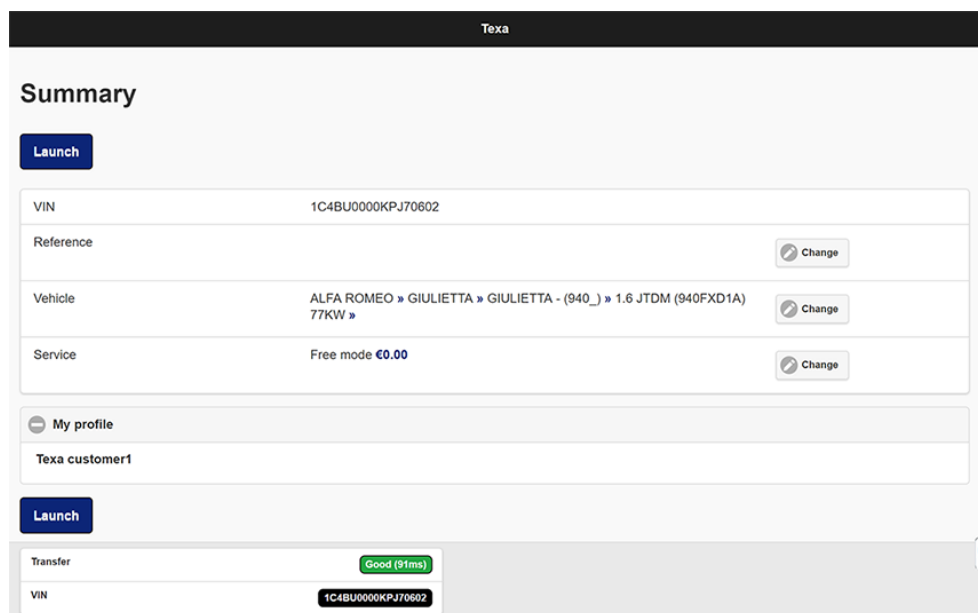

10. Press



The request for remote diagnosis is sent to the TEXA Call Center operator who will then manage it.

When the connection is established, the following screen is displayed:

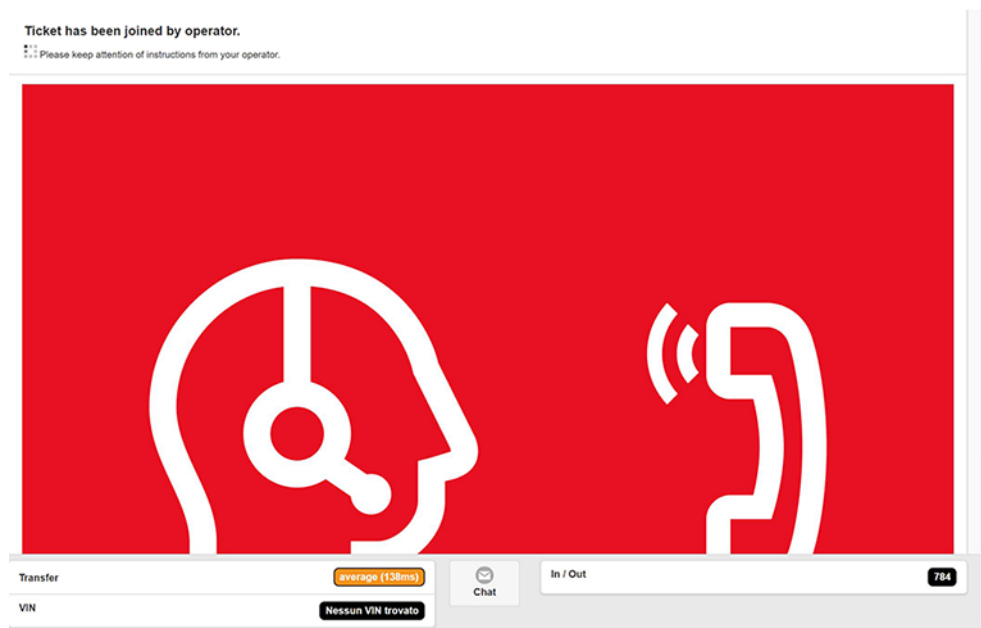

A Chat is available for the customer and the TEXA Call Center operator. The Chat can be started by both for any type of communication.

- 11. Press  .

Follow the instructions given by the TEXA Call Center operator (*for example: turn the vehicle's instrument panel on or off*), until the end of the diagnostic operation.

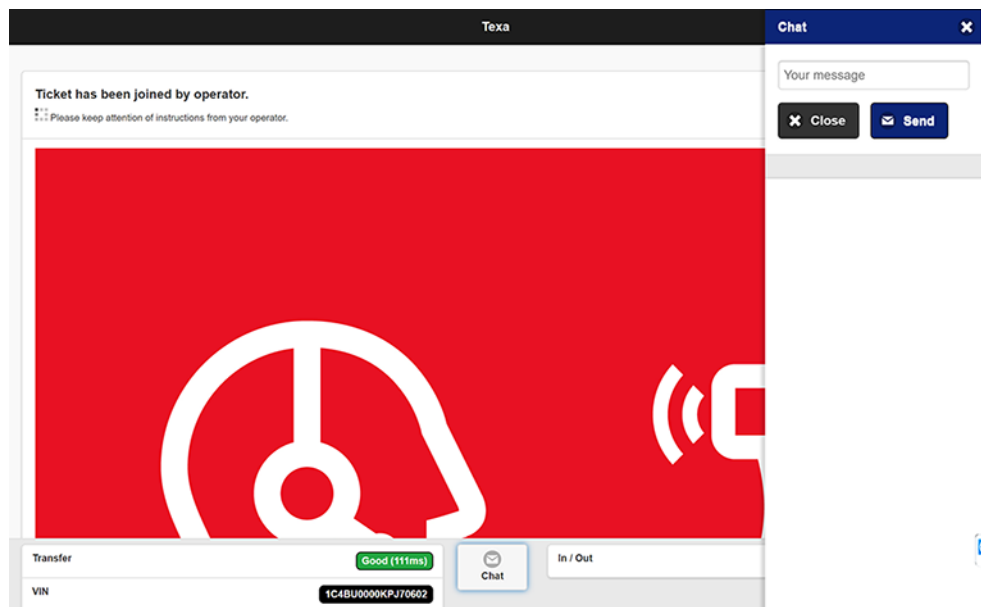

Once the diagnostic operation is complete, the TEXA operator closes the remote connection.

The screen indicating that the connection has been ended is displayed.

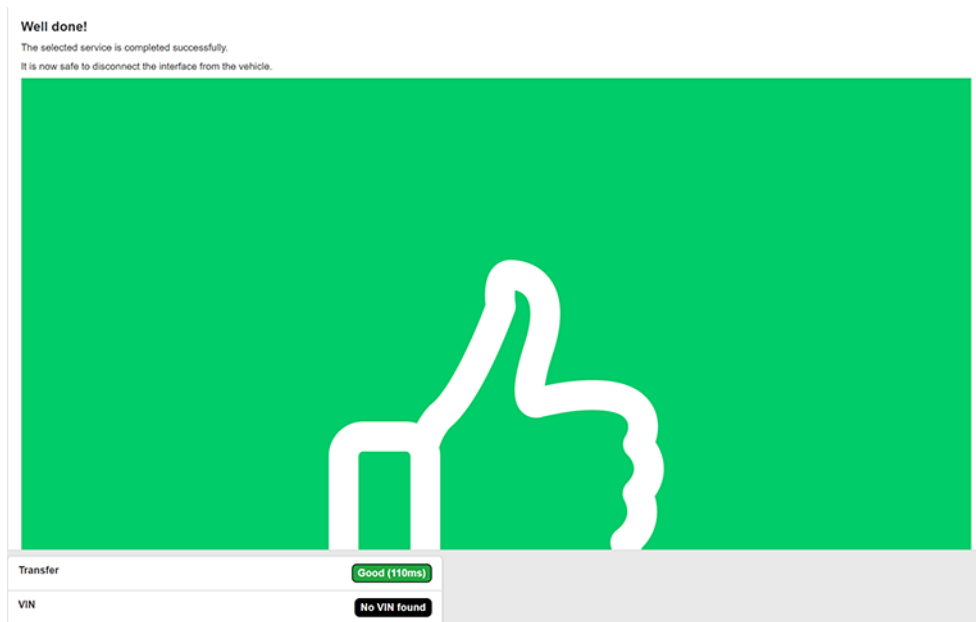

A good Internet must be guaranteed for the operation requested to be carried out successfully.

The status of the connection speed is indicated in the *Transfer* field:

- *Green: Good transfer (the operation will most probably be completed);*
- *Yellow: Average transfer (the operation may be interrupted and not be carried out successfully);*
- *Red: Poor transfer (check the coverage of the Internet signal and/or change the settings in order to guarantee an adequate signal).*

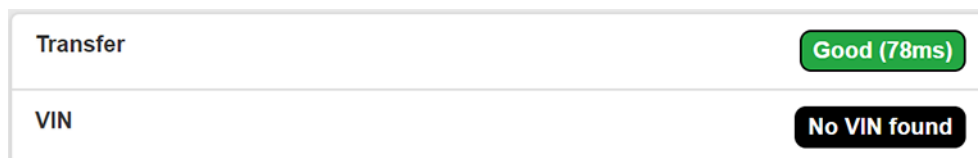

NOTICE

Keep the vehicle's batteries charged during the diagnostic operation.

The lack of a battery voltage stabiliser may compromise the outcome of the operation.

25.2 INFO CONNECT 2

1. Access the portal.
2. Press:

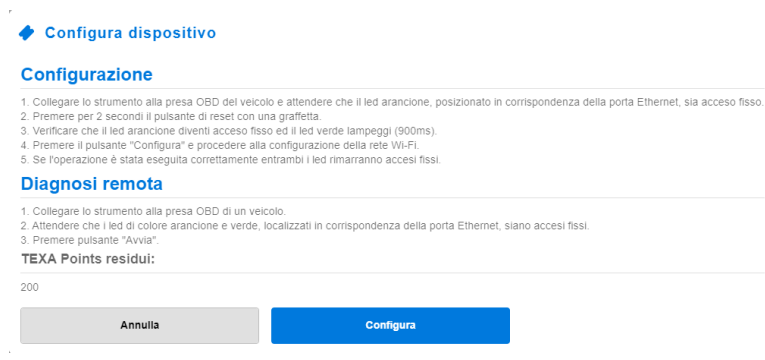

25.2.1 Configuration

The first time you use **INFO CONNECT 2** it must be configured.

Proceed as follows:

1. Connect the tool to the **OBD** socket and wait for the orange **LED**, located near the Ethernet port, to be solid ON.
2. Using a clip, press the **RESET** button for 2 seconds.
3. Make sure the orange **LED** is lit and that the green **LED** is flashing (900 ms).
4. Press **CONFIGURE**.
5. Select the workshop's Wi-Fi network.

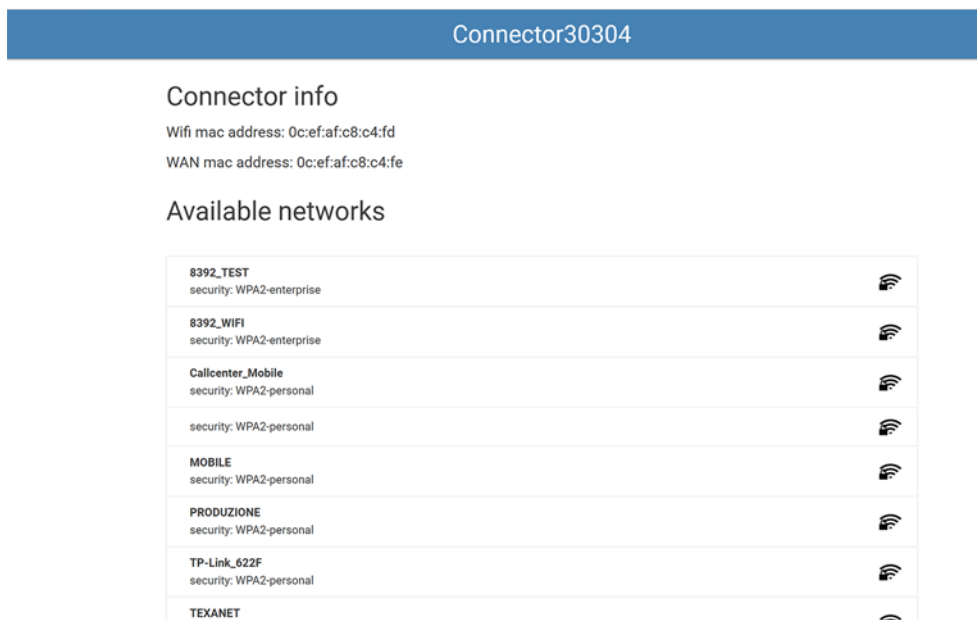

6. Enter the network's protection password (if required).
7. If the operation was successful, both LEDs on the Ethernet port turn on.

8. Press **START**.

[Inizia ticket](#)

Configurazione

1. Collegare lo strumento alla presa OBD del veicolo e attendere che il led arancione, posizionato in corrispondenza della porta Ethernet, sia acceso fisso.
2. Premere per 2 secondi il pulsante di reset con una graffetta.
3. Verificare che il led arancione diventi acceso fisso ed il led verde lampeggi (900ms).
4. Premere il pulsante "Configura" e procedere alla configurazione della rete Wi-Fi.
5. Se l'operazione è stata eseguita correttamente entrambi i led rimarranno accesi fissi.

Diagnosi remota

1. Collegare lo strumento alla presa OBD di un veicolo.
2. Attendere che i led di colore arancione e verde, localizzati in corrispondenza della porta Ethernet, siano accesi fissi.
3. Premere pulsante "Avvia".

TEXA Points residui:

200

Annulla

Configura

Avvia

INFORMATION

The remote diagnosis requires payment in TEXA Points.

For further information on the payment methods in TEXA Points contact your retailer.

1. Connect the tool to the vehicle's **OBD** socket.
2. Wait for the orange and green **LEDs**, located in correspondence of the Ethernet port, to remain lit.
3. Press **START**.
4. Follow the instructions that appear on-screen.

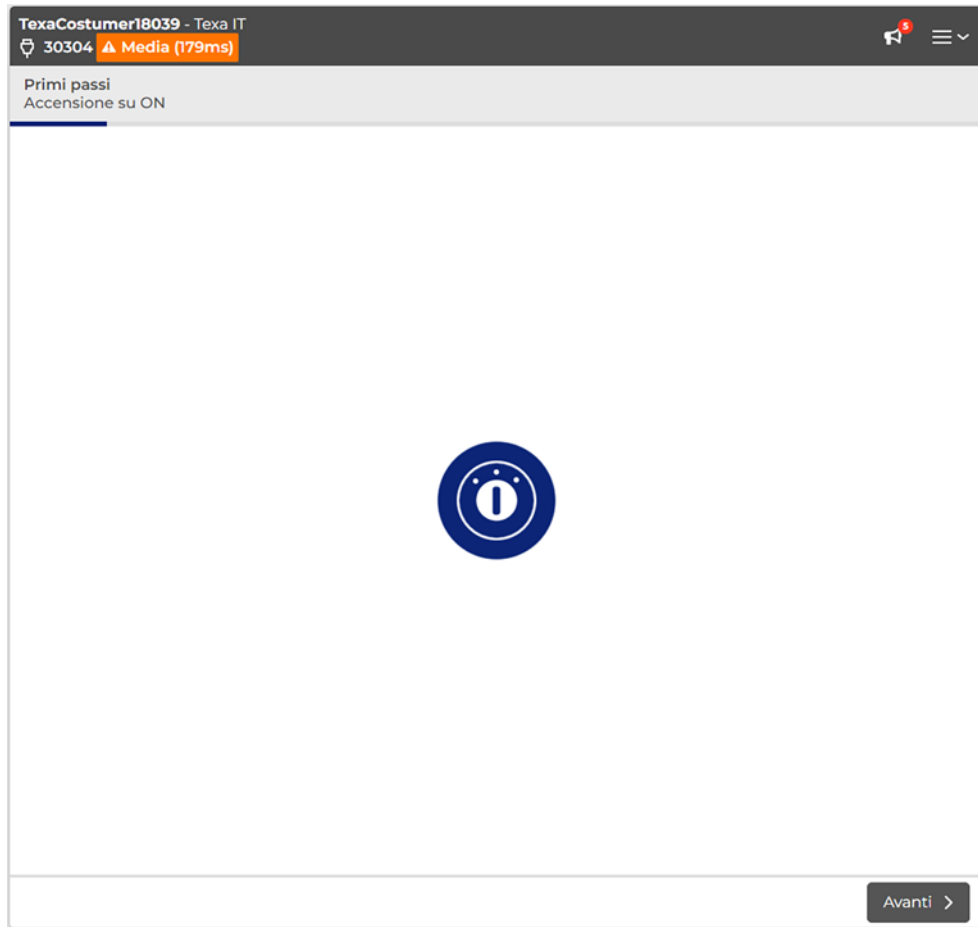

5. Press **NEXT**.
The VIN can be detected automatically.

6. Otherwise enter the VIN manually or select it in the history.

The screenshot shows a mobile application interface for creating a ticket. At the top, the status bar displays 'TexaCustomer18039 - Texa IT' and '30304 Buona (112ms)'. Below the status bar, the title 'Creazione del ticket' and subtitle 'Inserire il VIN per il ticket' are visible. The main content area has three sections:

- Rilevamento VIN automatico**: This option is selected with a radio button. Below it is a 'Controllo...' button with a refresh icon.
- Inserire il VIN manualmente**: This option is not selected. Below it is a text input field with the placeholder text 'INSERIRE IL VIN PER IL TICKET' and a character count '0 / 17'.
- Selezionare il VIN dallo storico**: This option is not selected and includes a dropdown arrow.

At the bottom of the screen, there are two navigation buttons: '< Indietro' on the left and 'Avanti >' on the right.

7. Press **NEXT**.

8. Select the vehicle you wish to diagnose by setting:

- *make*;
- *model*;
- *type*;
- *engine type*.

To pass from a selection level to the following, you must complete the previous one.

TexaCustomer18039 - Texa IT
 30304 Buona (101ms)

Creazione del ticket
 Selezione veicolo

Marchio JEEP	<ul style="list-style-type: none"> 1.4 MultiAir 103KW 552 63 624, EAQ 1.4 MultiAir 4x4 125KW 552 63 623, EAQ 1.6 CRD 88KW 552 60 384, EJJ 1.3 96KW 552 82 328
Modello COMPASS	<ul style="list-style-type: none"> 1.3 Hybrid 4x4 177KW 46337540 1.3 110KW 552 82 328 1.3 Hybrid 4x4 140KW 46337540
Tipo COMPASS - (MP, M6, MV, M7)	<ul style="list-style-type: none"> 1.6 Multijet 96KW 46346020 1.3 Hybrid 4x4 132KW 46337540 1.5 T4 Hybrid 96KW 46347812
Motore Seleziona...	<ul style="list-style-type: none"> 2.0 CRD 4x4 103KW 552 63 087, EBS, EBT 2.0 CRD 4x4 125KW 552 63 088, EBS

< Indietro Avanti >

9. Press **NEXT**.

10. Among the ones listed, select the type of operation you wish to carry out.

TexaCustomer18039 - Texa IT
 30304 Buona (67ms)

3C4NJDBY4JT353665 JEEP | COMPASS | (MP, M6, MV, M7) | 2.0 CRD 4x4 103KW 552 63 087, EBS, EBT 12.5V

Creazione del ticket
 Servizio da offrire

Retrofit	>
Manutenzione e Ispezione	>
Assistenza, Guasti Comuni	>
Sostituzione modulo	>
Multimedia, Impostazioni Infotainment	>
ADAS	>
Module Flash Programming	>

< Indietro

The list appears when the vehicle has been selected correctly.

INFORMATION

The operations that are available depend on the make and model of the vehicle selected.

11. Check the operation selected and related cost.

TexaCustomer18039 - Texa IT
30304 Buona (91ms)

3C4NJDBY4JT353665 JEEP | COMPASS | (MP, M6, MV, M7) | 2.0 CRD 4x4 103KW 552 63 087, EBS, EBT

Creazione del ticket
Servizio da offrire

Seleziona servizi opzionali:

✓ Sostituzione Centralina Airbag **TC 54** (TC ± 5.039,78)
lordo TC 54 (TC ± 5.039,78) | 0% Sconto
[Mostra altro >](#)

Seleziona servizi opzionali:

+ Impostazioni di Base Pretensionatore Cintura di Sicurezza **TC 54** (TC ± 5.039,78)
lordo TC 54 (TC ± 5.039,78) | 0% Sconto
[Mostra altro >](#)

Totale **TC 54** (TC ± 5.039,78)

< Indietro **Avanti** >

The cost of the operation varies based on the intervention required.

12. Press **NEXT**.

The summary screen is displayed.

TexaCostumer18039 - Texa IT
30304 Buona (84ms)

3C4NJDBY4JT353665 JEEP | COMPASS | (MP, M6, MV, M7) | 2.0 CRD 4x4 103KW 552 63 087, EBS, EBT 12.5V

Offri ticket
Panoramica ticket

Veicolo Nascondi dettagli ^

VIN
3C4NJDBY4JT353665

Tipo
JEEP | COMPASS | (MP, M6, MV, M7) | 2.0 CRD 4x4 103KW 552 63 087, EBS, EBT

Servizi selezionati

Description	Gross price	Net
Sostituzione Centralina Airbag	TC 54 (TC ± 5.039,78)	TC 54 (TC ± 5.039,78)
100022 - Airbag Module Replacement		
Sostituzione Centralina Airbag		
Subtotal	TC 54 (TC ± 5.039,78)	TC 54 (TC ± 5.039,78)

Fatturazione

Numero rivenditore
39e4051dff4d4491a5ed512eff9a8e61

Nome della società
TexaCostumer18039

+ Riferimento

+ Voucher

Totale TC 54

(TC ± 5.039,78) (TC ± 5.039,78)

< Indietro Crea >

13. Press **CREATE**.

The request for remote diagnosis is sent to the TEXA Call Center operator who will then manage it.

When the connection is established, the following screen is displayed:

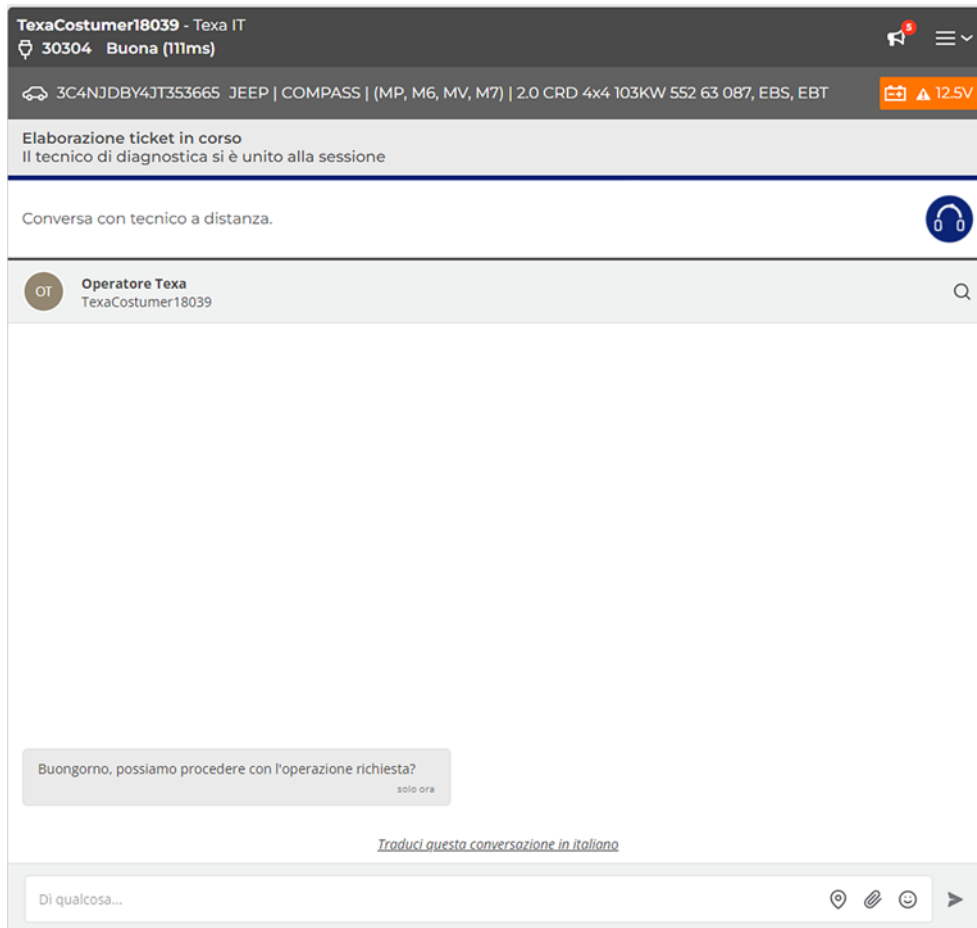

A Chat is available for the customer and the TEXA Call Center operator.

The Chat can be started by both for any type of communication.

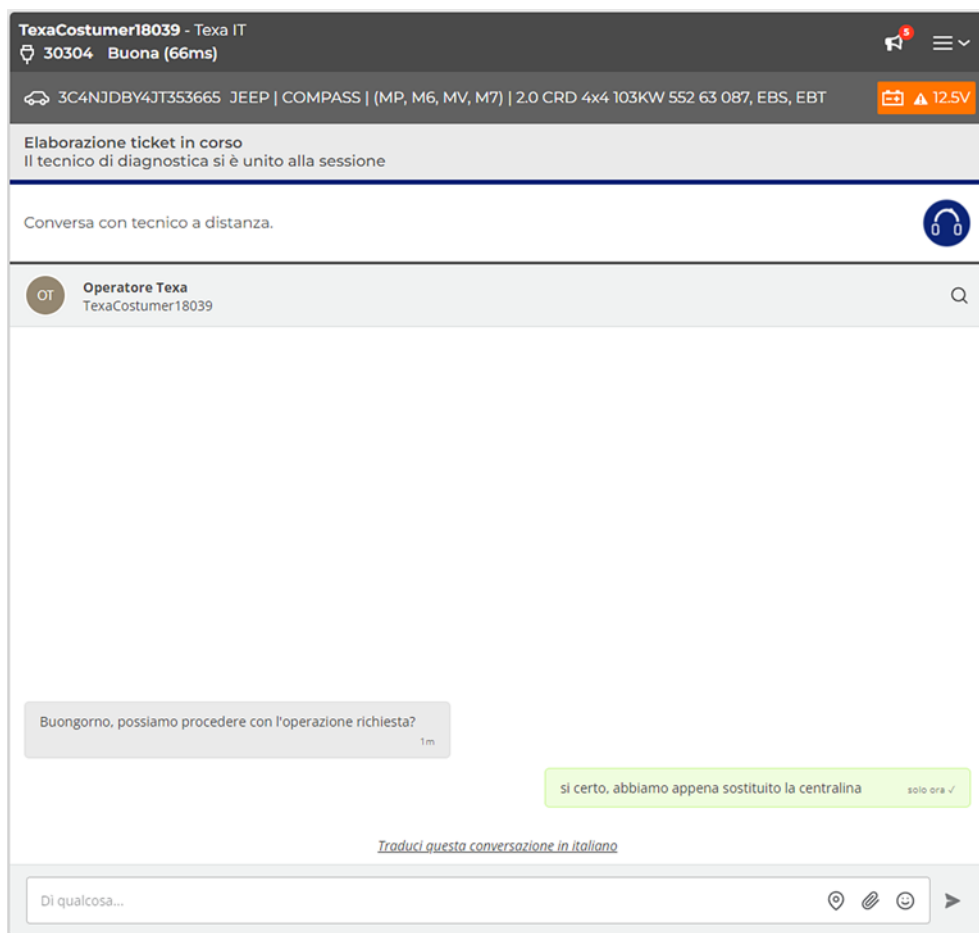

14. Follow the instructions given by the TEXA Call Center operator until the diagnostic operation is completed.

Once the diagnostic operation is complete, the TEXA operator closes the remote connection.

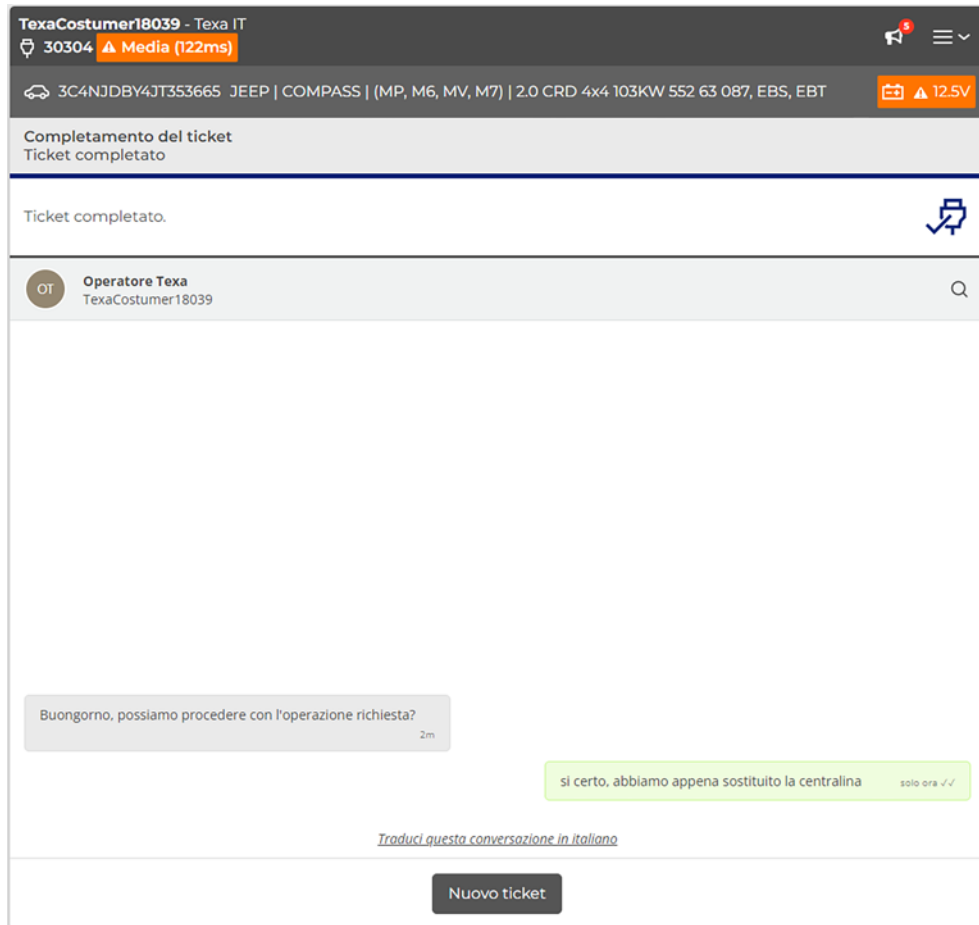

INFORMATION

A good Internet must be guaranteed for the operation requested to be carried out successfully.

The status of the connection speed is indicated at the top left of the screen:

- *good transfer: the operation will most probably be completed;*
- *average transfer (orange **alert**): the operation may be interrupted and not be carried out successfully;*
- *poor transfer (cred **alert**): check the coverage of the Internet signal and/or change the settings in order to guarantee an adequate signal.*

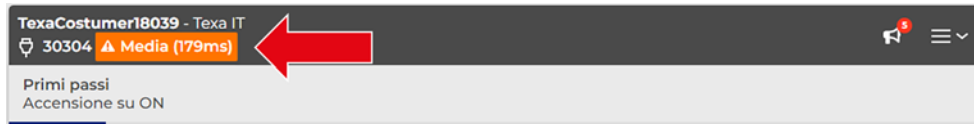

INFORMATION

Keep the vehicle's batteries charged during the diagnostic operation.

The lack of a battery voltage stabiliser may compromise the outcome of the operation.

25.3 REMOTE DIAGNOSIS SERVICES

25.3.1 Remote Diagnosis

INFORMATION

The remote diagnosis requires payment in **TEXA Points**.

For further information on the payment methods in **TEXA Points** contact your retailer.

The availability of the device depends on the software license purchased and on the version.

Proceed as follows:

1. Be sure to have at least one VCI configured.
2. Connect the tool to the vehicle's **OBD** socket.
3. Access the Remote Diagnosis portal using your **MyTEXA** credentials.

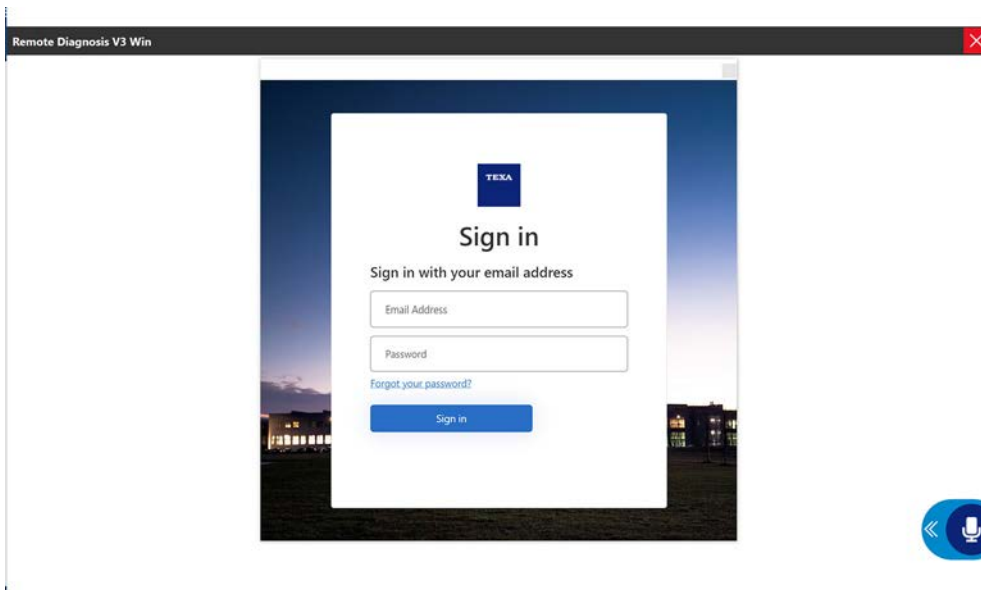

4. The dashboard is displayed.

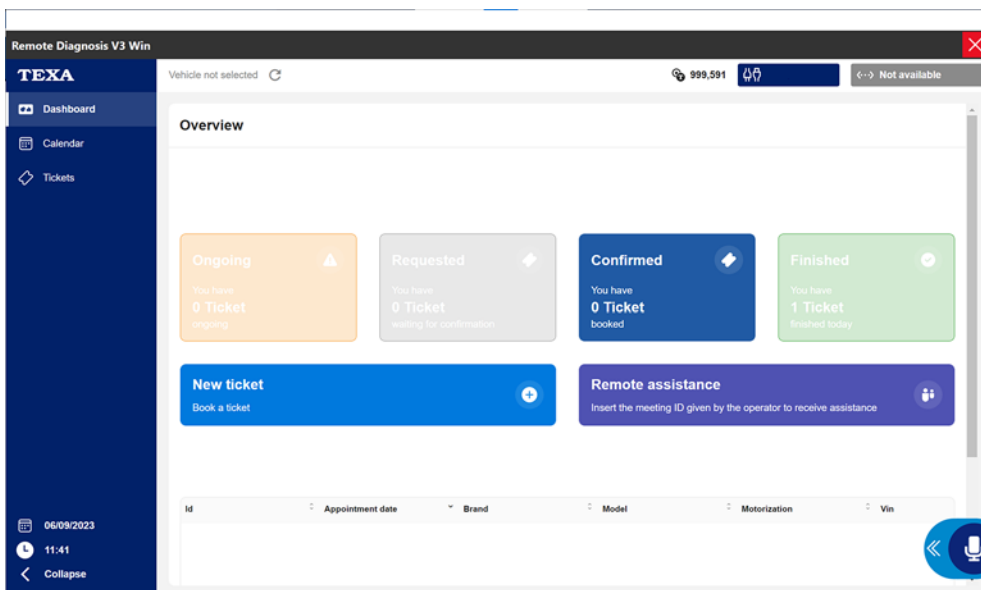

INFORMATION

If during the dashboard display operation the vehicle does not appear to be loaded, refresh the page.

The remote diagnosis requests are indicated in the dashboard:

- *ongoing*;
- *requested*;
- *confirmed*;
- *finished*.

5. To request a new remote diagnosis with the operator press **NEW TICKET**.

25.3.2 New remote diagnosis request

To request a new remote diagnosis proceed as follows:

1. Press **NEW TICKET**.

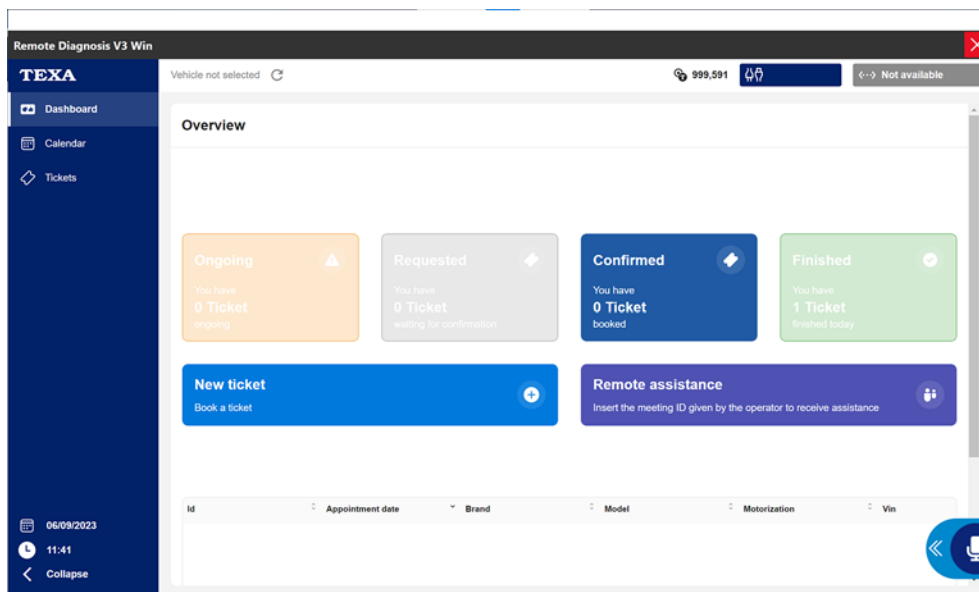

2. Select the **INFO CONNECT** tools you own among the ones available.

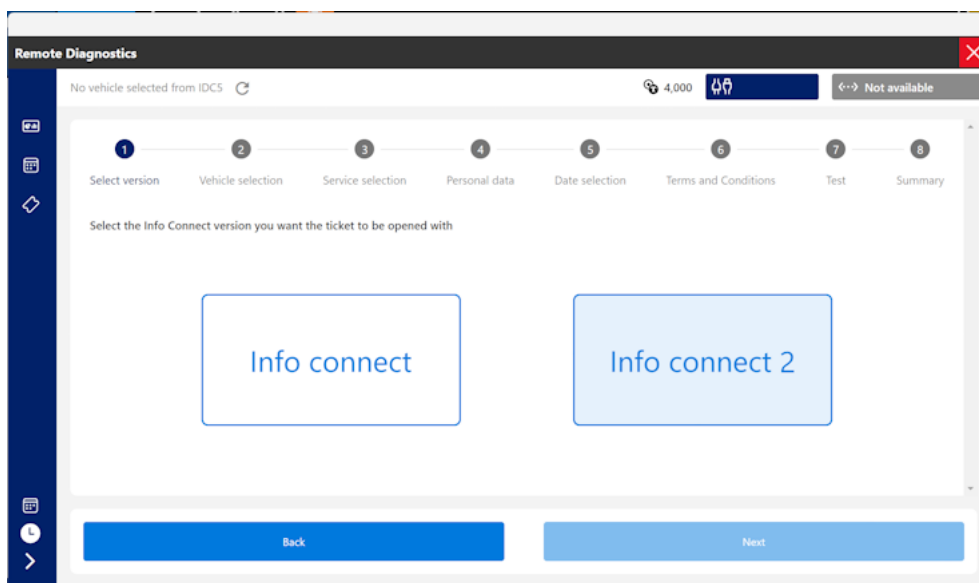

3. Enter the data related to the vehicle.

The screenshot shows the 'Remote Diagnosis V3 Win' application window. At the top, it says 'Vehicle not selected' and '999,591'. Below this is a progress bar with seven steps: 1. Vehicle selection (highlighted), 2. Services selection, 3. Personal data, 4. Date selection, 5. Disclaimers, 6. Condizioni generali del servizio, and 7. Summary. The main area is titled 'Insert vehicle data' and contains four input fields: 'VIN' with the value '0041', 'Brand*' with a dropdown menu showing 'Alfa', 'Model*' with the value '147', and 'Motorization*' with the value '1.6 Diesel'. At the bottom, there are 'Back' and 'Next' buttons, and a microphone icon on the right.

4. To move on to the following step, press **NEXT**.

The screenshot shows the 'Remote Diagnosis V3 Win' application window. At the top, it says 'Vehicle not selected' and '999,591'. Below this is a progress bar with seven steps: 1. Vehicle selection, 2. Services selection (highlighted), 3. Personal data, 4. Date selection, 5. Disclaimers, 6. Condizioni generali del servizio, and 7. Summary. The main area is titled 'Select the services you need' and features a search bar with the placeholder text 'Type something to search'. Below the search bar is a list of service categories with dropdown arrows: 'ADAS', 'Assistance, Common Faults', 'Module Replacement', 'Multimedia, Infotainment Settings', 'Retrofits', 'Service and Inspection', and 'Test'. On the right side, it says 'Selected services: 0'. At the bottom, there are 'Back' and 'Next' buttons, and a microphone icon on the right.

5. Select the type of service you need to request.

You can write the type of service in the search bar or select it among the ones suggested by the software.

6. Press **NEXT**.

Remote Diagnosis V3 Win

Vehicle not selected

999.591

Not available

1 2 3 4 5 6 7

Vehicle selection Services selection Personal data Date selection Disclaimers Condizioni generali del servizio Summary

Email*

Phone*

Enter an SMS-enabled phone number

Back Next

7. Enter your contact data.

The contact data is mandatory in order to be contacted by the operator.

8. Press **NEXT**.

Remote Diagnosis V3 Win

Vehicle not selected

999.591

Not available

1 2 3 4 5 6 7

Vehicle selection Services selection Personal data Date selection Disclaimers Condizioni generali del servizio Summary

SETTEMBRE 2023

LUN MAR MER GIO VEN SAB DOM

28 29 30 31 1 2 3

4 5 6 7 8 9 10

11 12 13 14 15 16 17

18 19 20 21 22 23 24

25 26 27 28 29 30 1

08:30 08:45 09:00 09:15 09:30 09:45

10:00 10:15 10:30 10:45 11:00 11:15

11:30 11:45 12:00 12:15 13:30 13:45

14:00 14:15 14:30 14:45 15:00 15:15

15:30 15:45 16:00 16:15 Available 16:30 Available 16:45 Available

17:00 17:15

Back Next

9. Select the date and time you wish to be contacted among the availabilities in the calendar.

10. Press **NEXT**.

11. Check the data in the summary screen.

12. Confirm the booking.

25.3.3 Start a remote diagnosis session

1. On the day booked, access the TICKET section.

If an operator is already connected, the ticket will be in the "ongoing" status.

2. Select the desired ticket.

Follow the instructions that appear on-screen.

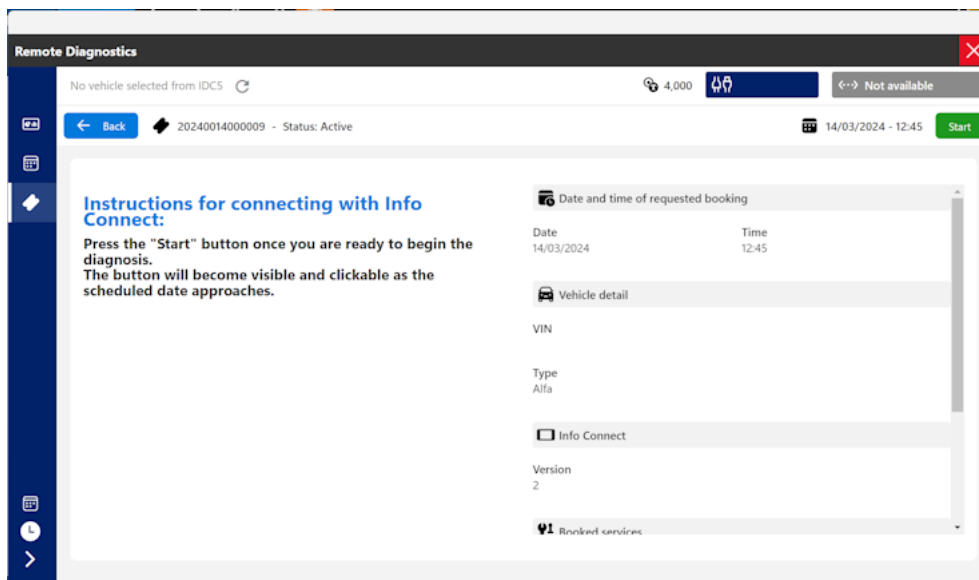

3. Press **START**.

A new session is started and you can configure your tool.

Follow the instructions that appear on-screen.

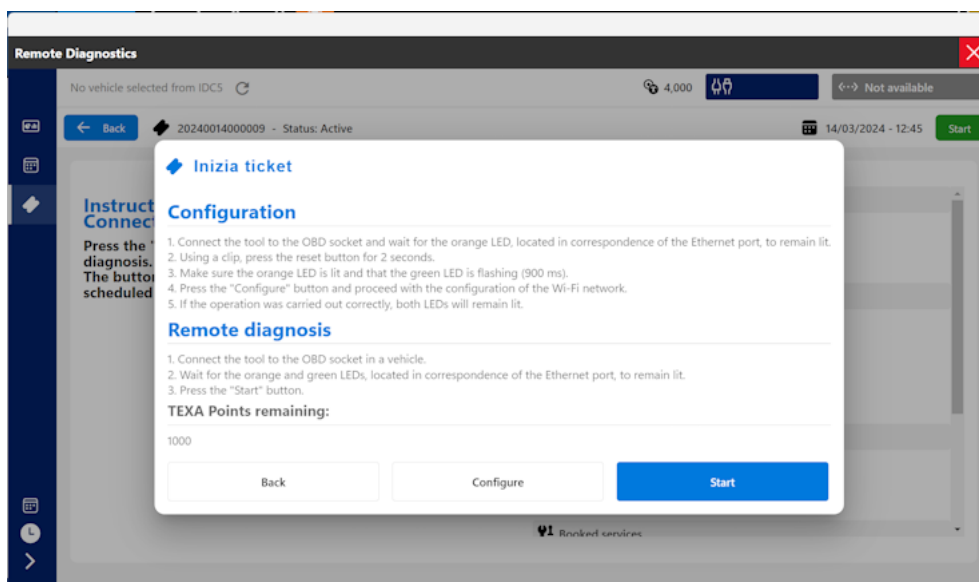

4. Press **START**.

The remote diagnosis service is started via the selected tool.

The user is connected with an operator.

INFORMATION

By pressing CONFIGURE a new device or a previously reset device can be configured.

25.3.4 Remote assistance

To make an assistance call, proceed as follows:

1. The booked day connect with the operator.
2. Press **REMOTE ASSISTANCE**.
3. Enter the ID code you received via email and/or SMS.
4. The connection with the operator is established.

25.3.5 Tickets menu

This menu allows viewing the history of the requested tickets.

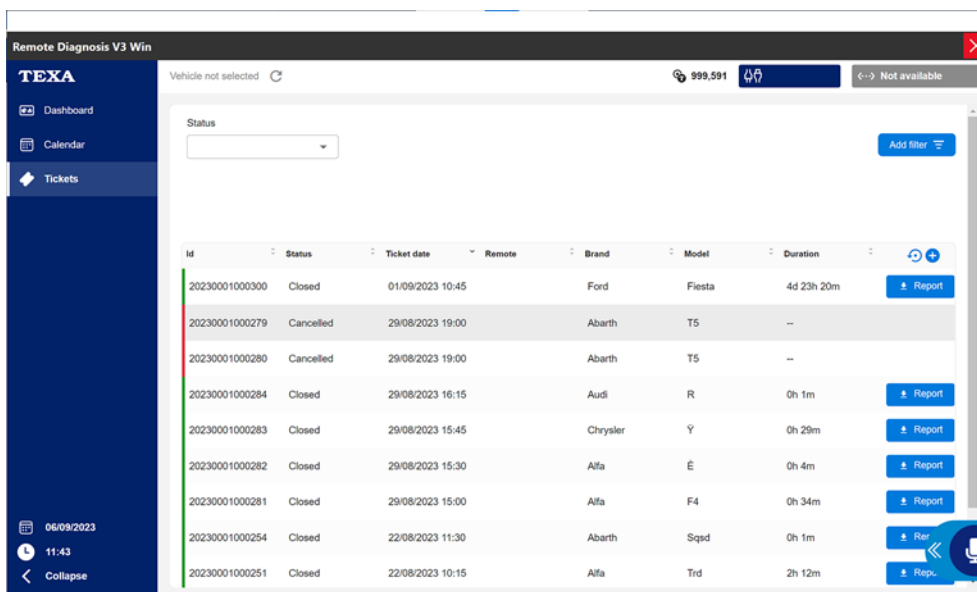

Item	Description
ID	It indicates the identification number given to the assistance request.
Status	It indicates the status of the assistance request: <ul style="list-style-type: none"> • <i>open</i>; • <i>closed</i>; • <i>cancelled</i>.
Ticket date	It indicates the date the ticket is created.
Make	It indicates the make of the vehicle the assistance was requested for.
Model	It indicates the model of the vehicle the assistance was requested for.
Duration	It indicates the duration of the remote assistance call.

25.3.6 Report

This function allows viewing and printing the report of the operation.

To view the report, press **REPORT**.

26 DYNAMIC TESTS



This function allows configuring the VCI for the recording of parameters, statuses (not for all the selections) and errors detected by the control units of a moving vehicle or boat.

The function records the errors that only occur when the vehicle is being used and monitors the parameters and statuses in situations that cannot be replicated in a workshop.

An example of a possible use is the following:

1. *The mechanic configures the device for the recording and returns the vehicle to the customer.*
2. *The customer drives the vehicle for a set period of time and then returns to the workshop.*
3. *The mechanic consults the recordings and, thanks to the information that was acquired, repairs accordingly.*

INFORMATION

The icon that allows launching the function will appear only if the VCI used for the diagnosis supports the recording mode.

In the VCIs that have a display, when using this mode, specific messages will appear to inform about the status of the VCI itself.

For more information, refer to the VCI technical manual.

Proceed as follows:

1. Carry out a complete vehicle selection.
2. Select the desired system.
3. Start the diagnosis.
4. Press: **Parameters**
5. Create a group of favourite parameters.

INFORMATION

The parameters and the statuses that can be monitored depend on the selection made.

6. Press:



TEHA MULTI-BRAND DIAGNOSIS

FIAT/Punto (95-03) (130) 1.2 16v Kat/Hatchback/100 A 1.000 (59 kW)(L-999-03) Petrol injection
Bosch/Motronic/MC 7.294(L-071-3) Euro 3

NEW*

Intake air temperature	-5 °C -5 ▲▼ -5
Throttle valve position	0 ° 0 ▲▼ 0
Intake manifold pressure	0 hPa 0 ▲▼ 0

Navigation icons: back, save, edit, print, refresh, stop, home, zoom, search.

7. Press:



TEHA MULTI-BRAND DIAGNOSIS

FIAT/Punto (95-03) (130) 1.2 16v Kat/Hatchback/100 A 1.000 (59 kW)(L-999-03) Petrol injection
Bosch/Motronic/MC 7.294(L-071-3) Euro 3

The device will now be configured in the "Dynamic Tests" mode, sampling the parameters selected in the current "group of favourites".

Navigation icons: back, help, confirm.

Icon	Name	Description
	Help	It allows displaying a technical sheet with useful information about the function use.
	Confirm	Allows you to continue the configuration of the trip.

8. Tick the box: **I have read and accept the conditions**

9. Press: 

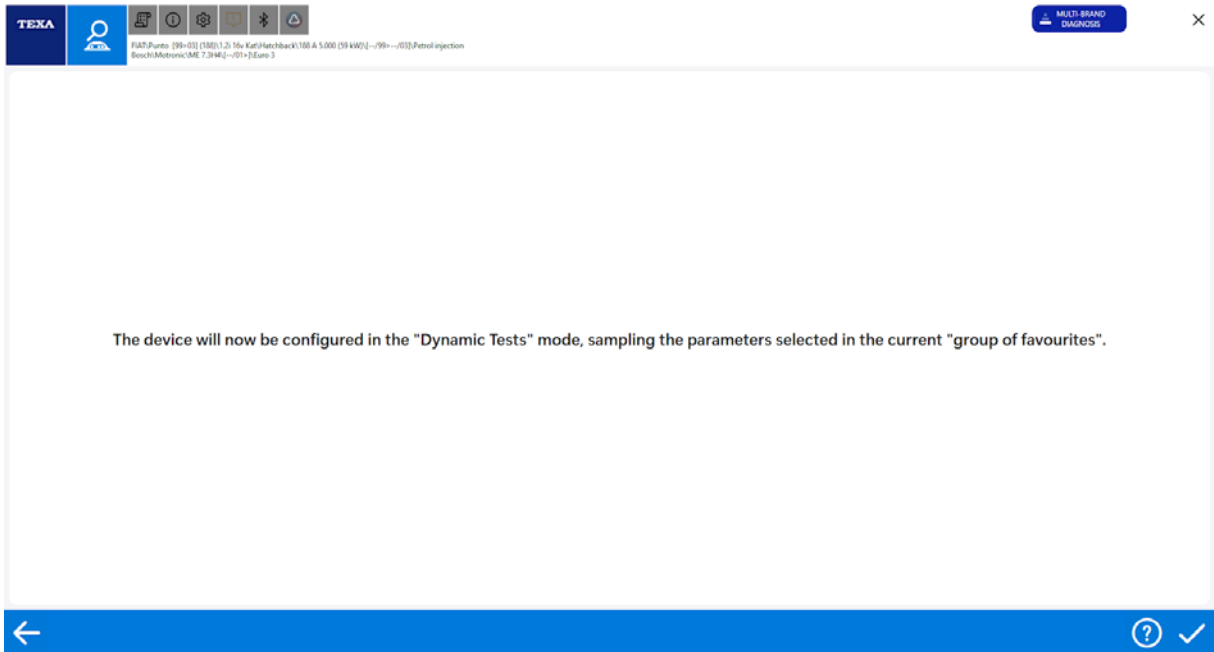

10. Enter the vehicle licence plate number.

11. Press: **Confirm**

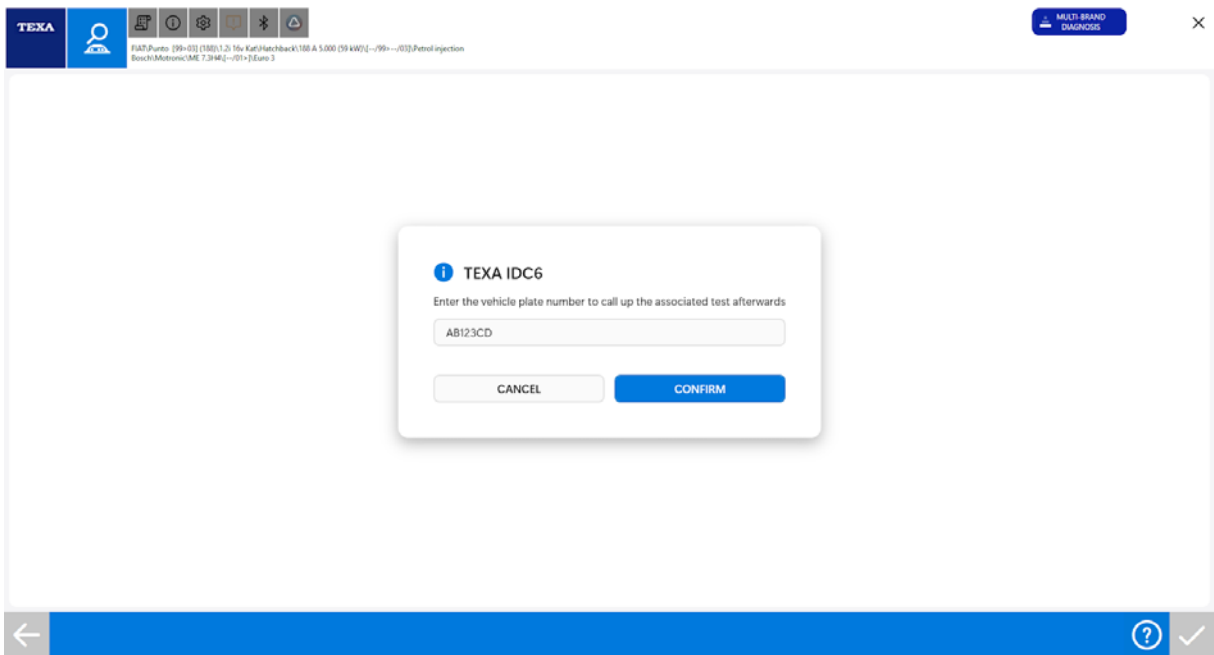

12. Read carefully.

13. Press: 

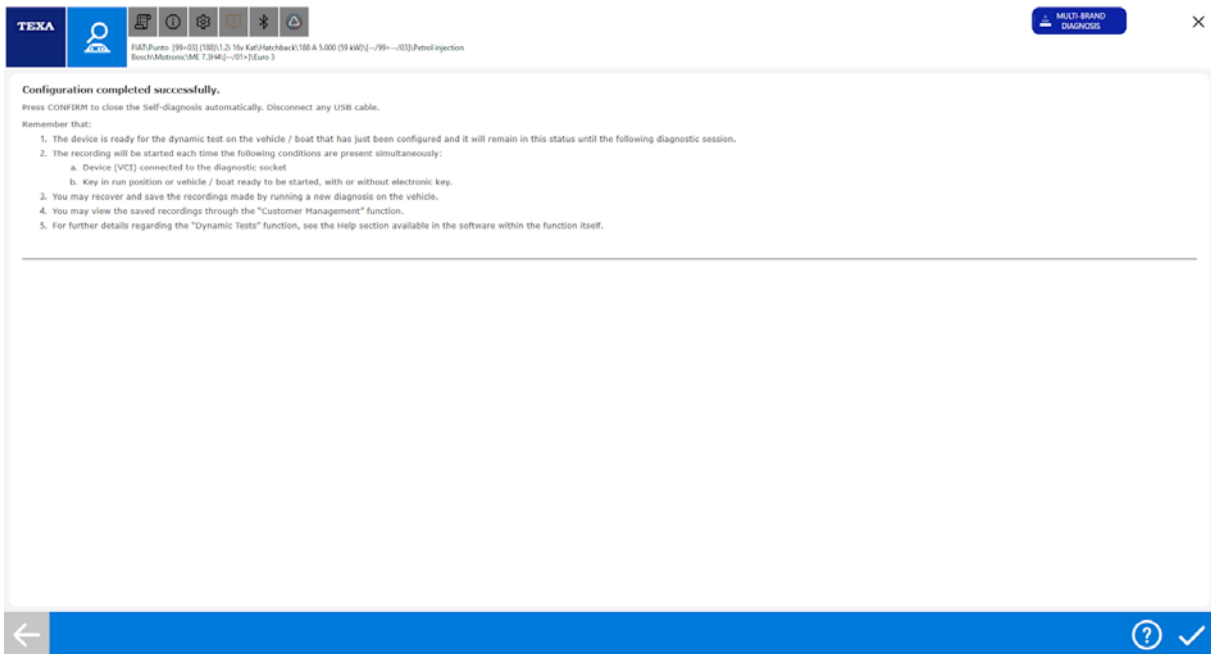

The device is ready to start recording the selected parameters / statuses.

CAUTION

Be sure to position the device and the cable so that they do not compromise safe driving nor the driver's safety.

In particular, do not place the device in the airbag expansion areas.

Stay focused on driving during the dynamic tests.

INFORMATION

The recorded data is organised in trips.

The recording of a trip starts when:

- *the device is connected to the diagnostic socket and the key is in the run position;*
- *the device is connected to the diagnostic socket and the vehicle is ready to be started, with or without electronic key.*

The recording of a trip ends when the vehicle's instrument panel is turned off or after 8 consecutive hours of recording.

After 8 hours, the device emits an audible warning signal.

You must disconnect and reconnect it to the diagnostic socket in order to re-enable the recording mode.

26.1 Trip Import

Once the dynamic test is complete, the recording of the parameters and errors can be imported and then displayed.

INFORMATION

You can import the dynamic tests only if you access the diagnosis in the same environment from which the recording function was started (e.g. CAR).

Before being able to launch the diagnosis in a new environment (e.g. TRUCK), you need to import the recorded tests in the environment they refer to.

Proceed as follows:

1. Power the VCI.
2. Carry out a complete vehicle selection.

INFORMATION

It is not necessary to select the same vehicle for which a dynamic test was performed.

3. Select a system.
4. Press:**START**

The software detects that there are trips stored in the VCI and suggests importing them.

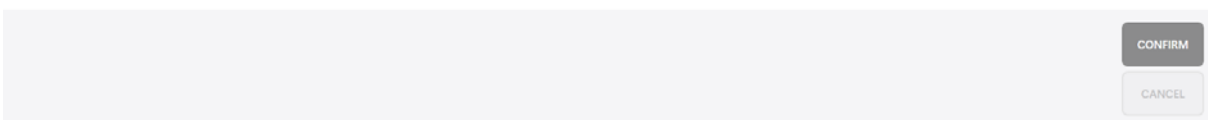
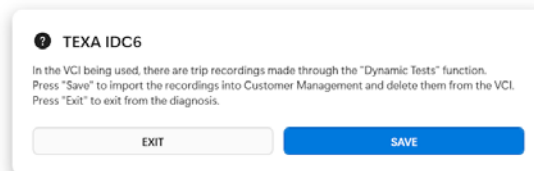

5. Press:**SAVE**

The software suggests displaying the imported trips.

6.

© copyright and database right 2024 CAR 2024.1 A

7. Press: **YES**

The screen with the recorded trips is displayed.



Duration of the recording	Number of errors
00:00:51	13
00:01:30	12
00:00:07	10

Select the trip to analyse

Icon	Name	Description
	View Trip	Allows you to view the selected trip.
	Error Information	Allows you to view the errors that have been detected during the recording.
	Export data	It allows you to save a report of the selected trip in CSV * format on your PC.

(* *Comma-separated values (abbreviated to CSV) is a file format based on text files used for importing and exporting (for example from spreadsheets or databases) a data chart.*

The LED next to the trip indicates, according to the colour, if errors have or have not been detected.

LED	Description
	The device did not detect errors during the performed trips.
	The device has detected at least one error during one of the performed trips.

26.2 View Trip

This function allows you to view the trips carried out.

Proceed as follows:

1. Select the desired trip.

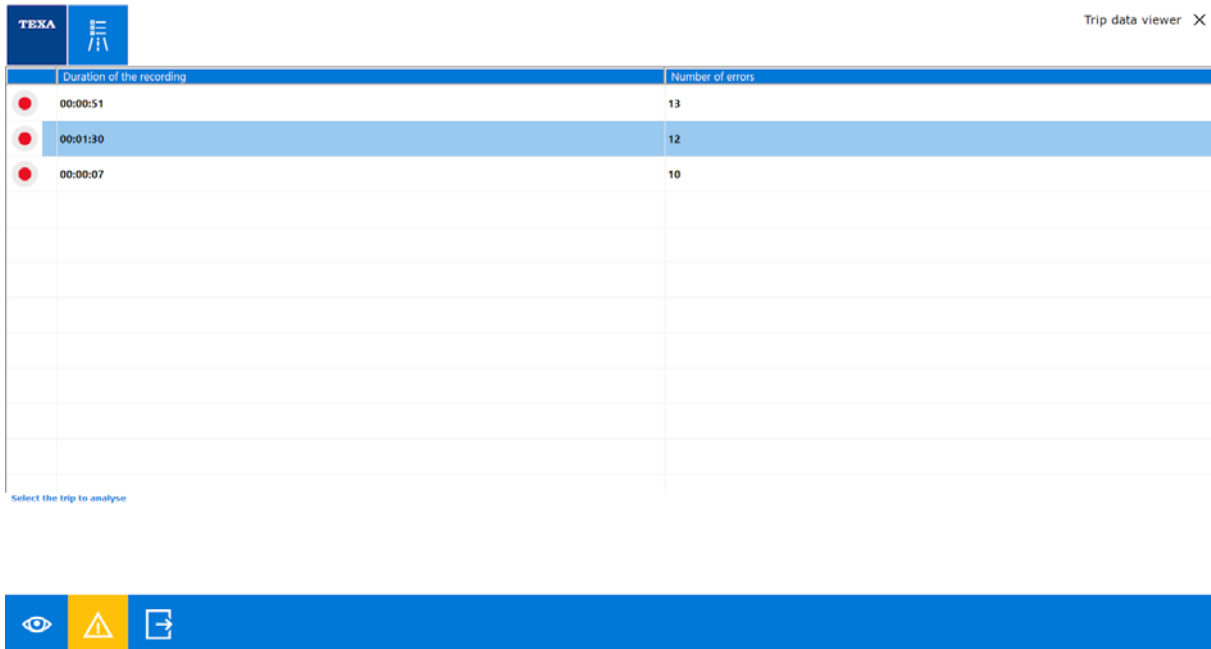

The screenshot shows the 'Trip data viewer' interface. At the top left is the 'TEXA' logo and a menu icon. At the top right is the text 'Trip data viewer' with a close icon. Below this is a table with two columns: 'Duration of the recording' and 'Number of errors'. The table contains three rows of data, with the second row highlighted in blue. Below the table is a blue bar with three icons: an eye, a warning triangle, and a right-pointing arrow.

Duration of the recording	Number of errors
00:00:51	13
00:01:30	12
00:00:07	10

2. Press: 

3. Select the desired parameters.

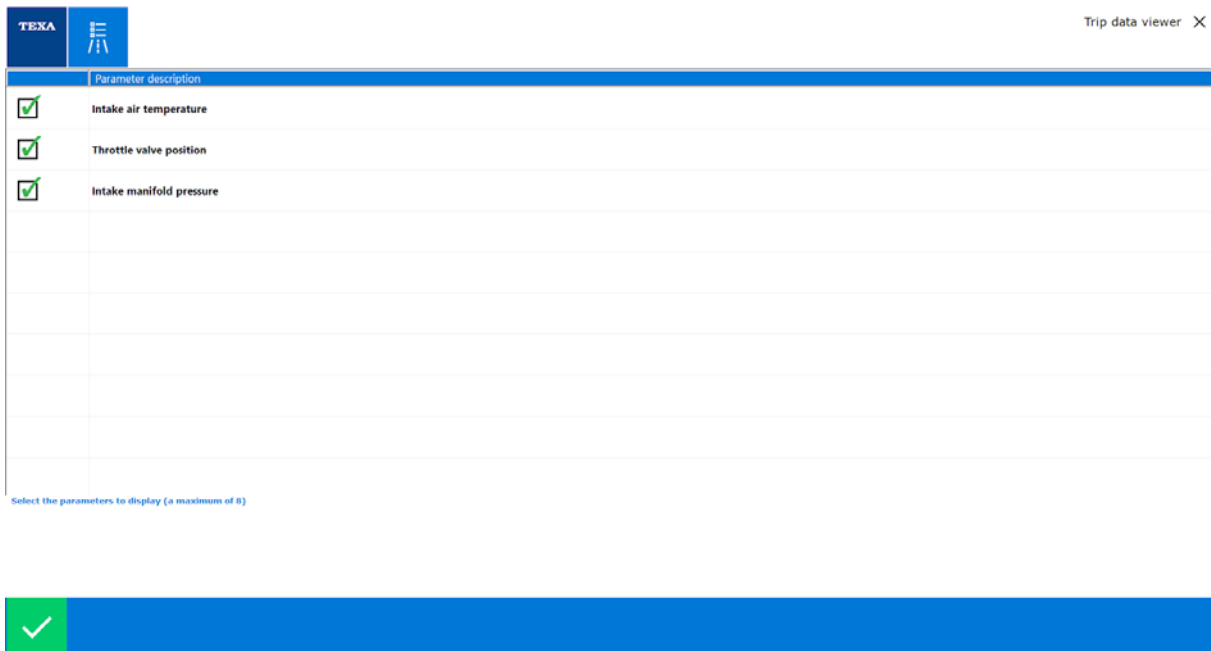

The screenshot shows the 'Trip data viewer' interface. At the top left is the 'TEXA' logo and a menu icon. At the top right is the text 'Trip data viewer' with a close icon. Below this is a table with one column: 'Parameter description'. The table contains three rows of data, each with a green checkmark in the first column. Below the table is a blue bar with a green checkmark icon.

Parameter description
<input checked="" type="checkbox"/> Intake air temperature
<input checked="" type="checkbox"/> Throttle valve position
<input checked="" type="checkbox"/> Intake manifold pressure

4. Press: 

The diagram with the recorded parameters / statuses is displayed.



Trip data viewer X



26.2.1 Zoom

You can zoom in a section of the graphs to analyse in detail the behaviour of the selected parameters in a specific time frame.

Proceed as follows:

1. Position the cursor-bar in the desired point.
2. Keep pressed and drag to the right until selecting the entire desired time frame.

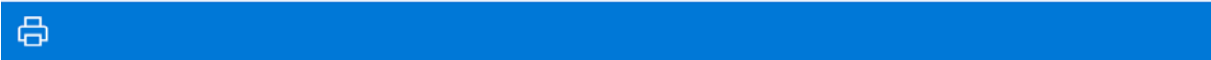

3. Release the pressure.

The section of the graphs for the selected time frame is zoomed in.



Icon	Name	Description
	Zoom out	It allows zooming out and returning to the normal graph display.

		
	Forward / Back	They allow moving forward and back in the zoom.

26.3 Error Information

This function allows you to view the errors detected during the recording.

Proceed as follows:

1. Select the desired trip.









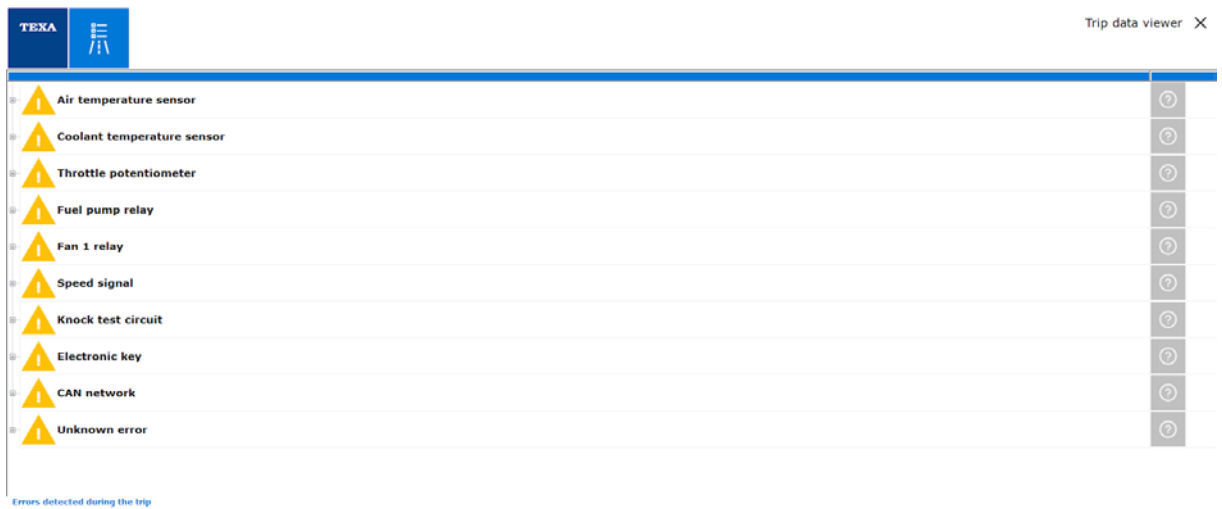













TEXA Trip data viewer X

Duration of the recording	Number of errors
00:00:51	13
00:01:30	12
00:00:07	10

Select the trip to analyse



TEXA Trip data viewer X

 Air temperature sensor	
 Coolant temperature sensor	
 Throttle potentiometer	
 Fuel pump relay	
 Fan 1 relay	
 Speed signal	
 Knock test circuit	
 Electronic key	
 CAN network	
 Unknown error	

Errors detected during the trip

2. Press:



The detected errors are displayed.

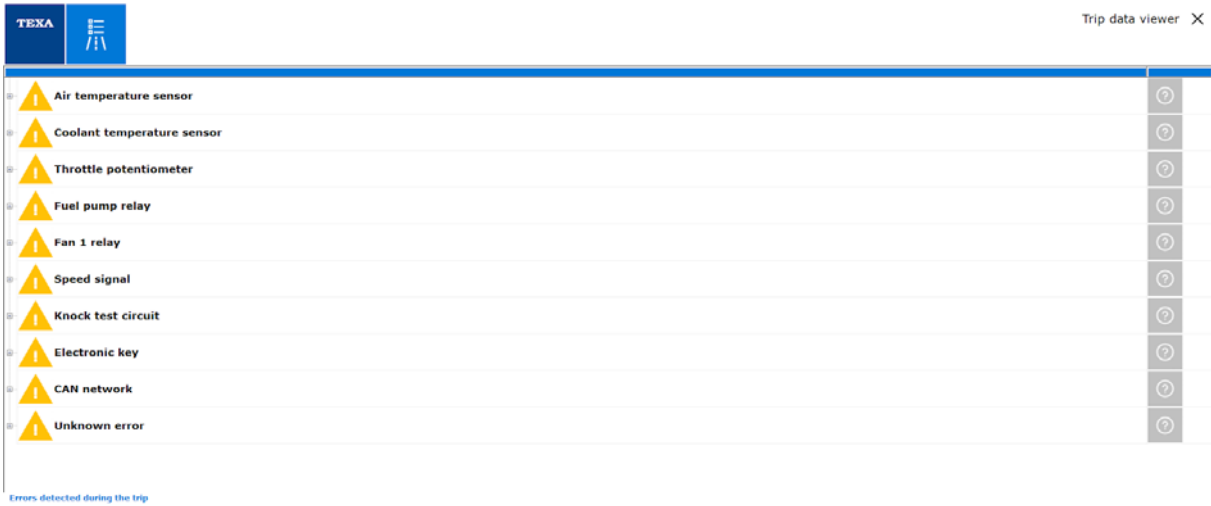

Press on the desired error to view its details.

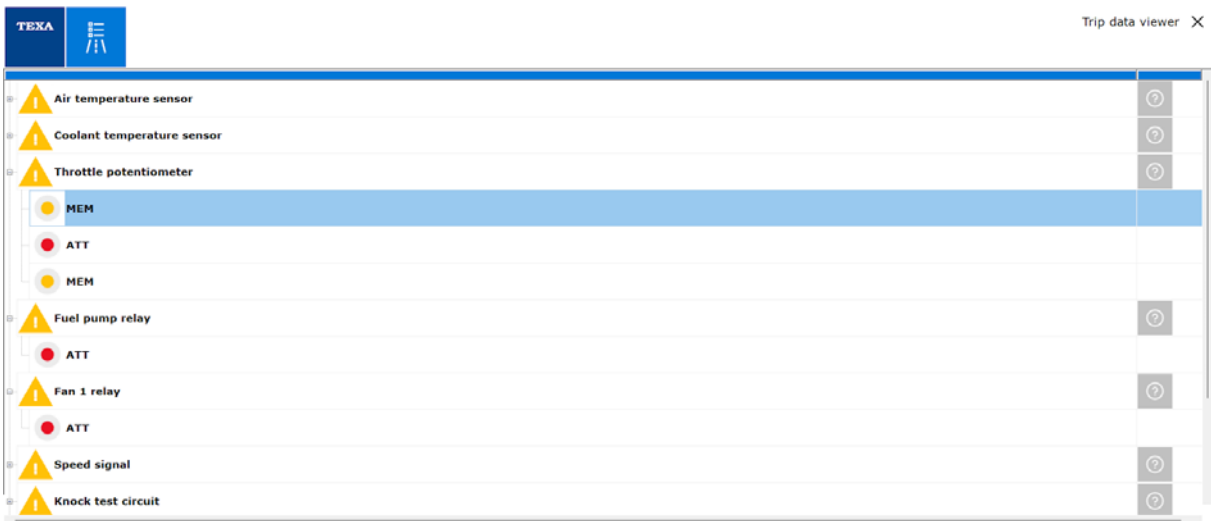

Icon	Name	Description
	Information	It allows you to view a help screen related to the error.

27 MILEAGE AND VIN CHECK



This function allows reading the mileage and/or VIN values stored in the vehicle control units, and then launching a diagnosis.

Proceed as follows:

1. Press: 
2. Carry out a complete selection.

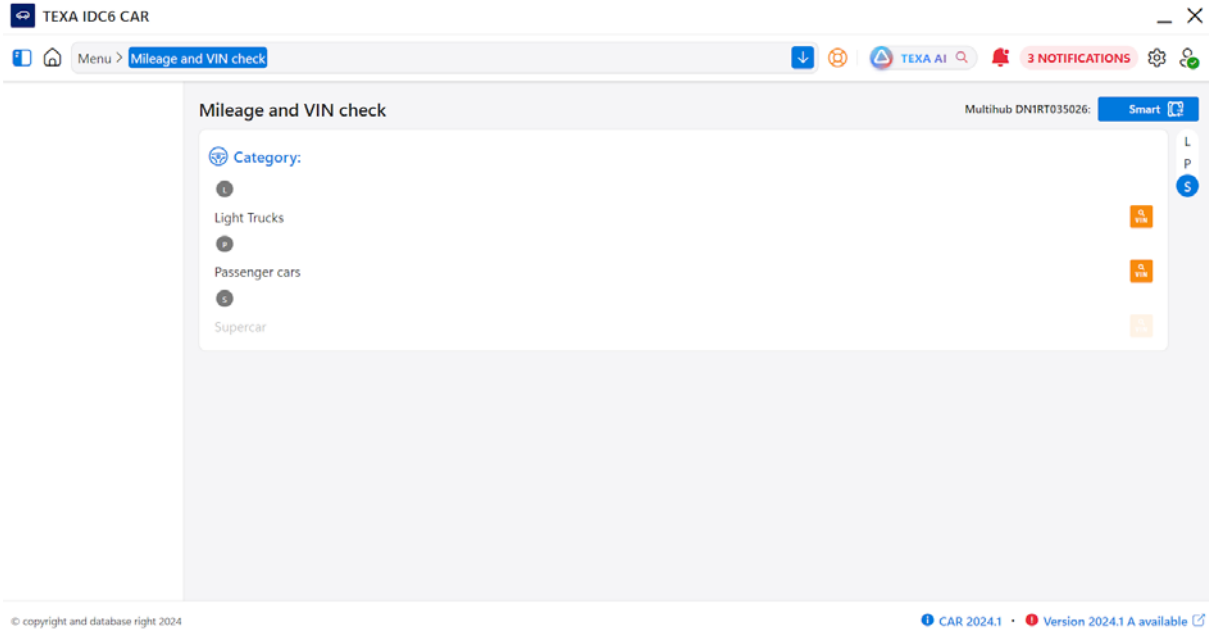

3. Press: 

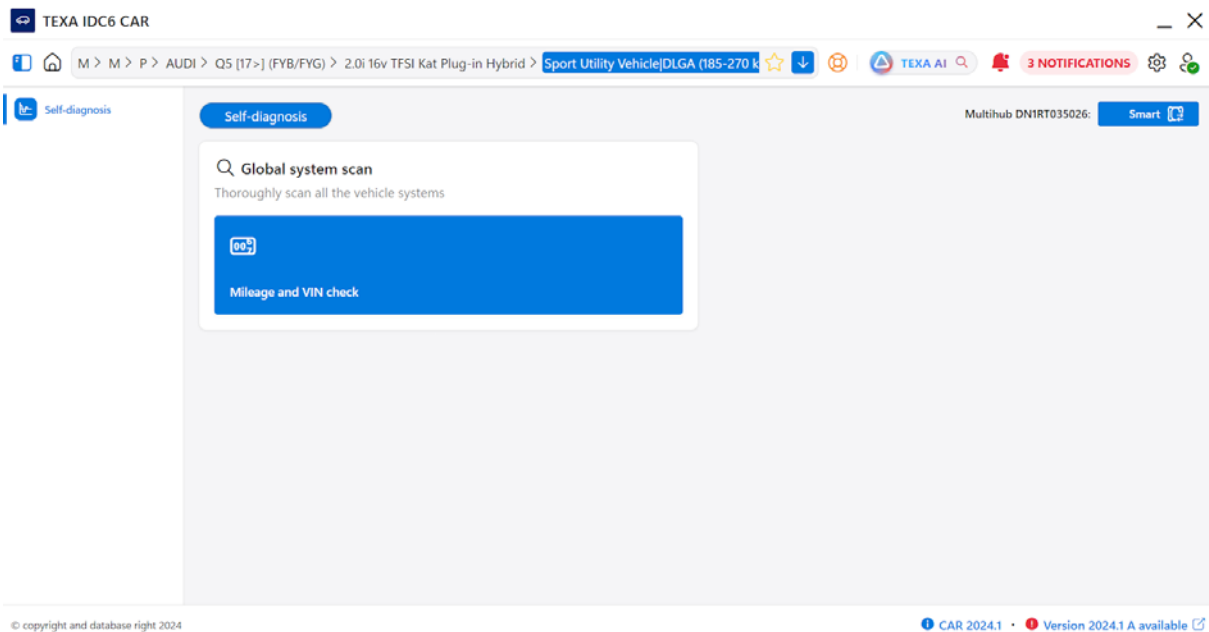

The result of the scan is displayed.

TEXA 1633s AUDI\Q5 [17>] (FYB\FYG)\2.0l 16w TFSI Kat Plug-in Hybrid\Sport Utility Vehicle\DRVA (195-270 KW)\[-/21>

MULTI-BRAND DIAGNOSIS VIN WAUZZZF4Y8R2031000 13.8 V

MILEAGE AND VIN CHECK

0023 Brake booster Bosch - - - -	W VIN WAUZZZF4Y8R2031000 Not available
0015 Airbag - - - - -	W VIN WAUZZZF4Y8R2031000 Not available
0002 Automatic transmission - (0CK) DL382-7F / (0CJ) (DSG) - 7 ratio gearbox	W VIN WAUZZZF4Y8R2031000 Not available
0002 Automatic transmission - (0B5) DL501 (DSG) - 7 ratio gearbox	W VIN WAUZZZF4Y8R2031000 Not available
0046 Comfort system Continental - - - -	W VIN WAUZZZF4Y8R2031000 Not available
0075 Rescue call - - - - Variant B	W VIN WAUZZZF4Y8R2031000 Not available
0001 Petrol injection - - - - -	W VIN WAUZZZF4Y8R2031000 Not available
0009 Switchover board - - - - -	W VIN WAUZZZF4Y8R2031000 Not available
0017 Instrument panel - - - - -	W VIN WAUZZZF4Y8R2031000 27019 km
0019 Gateway Continental - - - -	W VIN WAUZZZF4Y8R2031090 Not available
00A5 Multifunction videocamera Kostal - Driver-assistance system - -	W VIN WAUZZZF4Y8R2031000 27019 km

4. Select the desired control unit.

5. Press: 

6. Follow the instructions that appear on screen.

28 VEHICLE MAINTENANCE



This section allows accessing the ACTIVATIONS and ADJUSTMENTS functions for the specific component selected.

Proceed as follows:

1. Press:

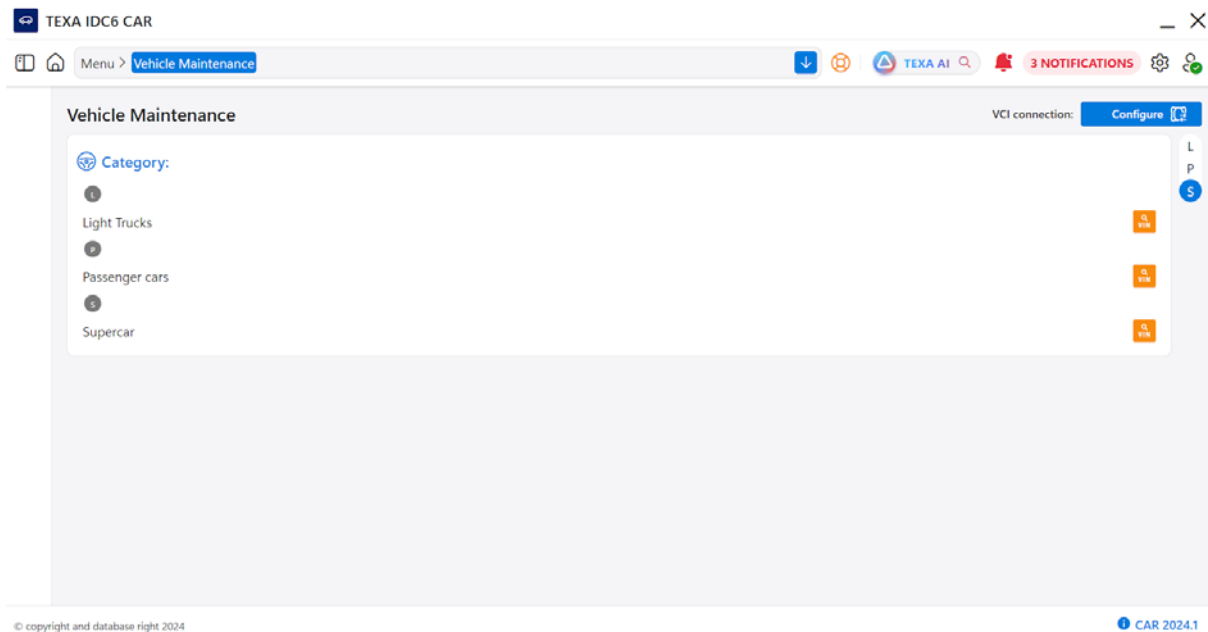

2. Carry out a complete selection.

3. Select the type of system.

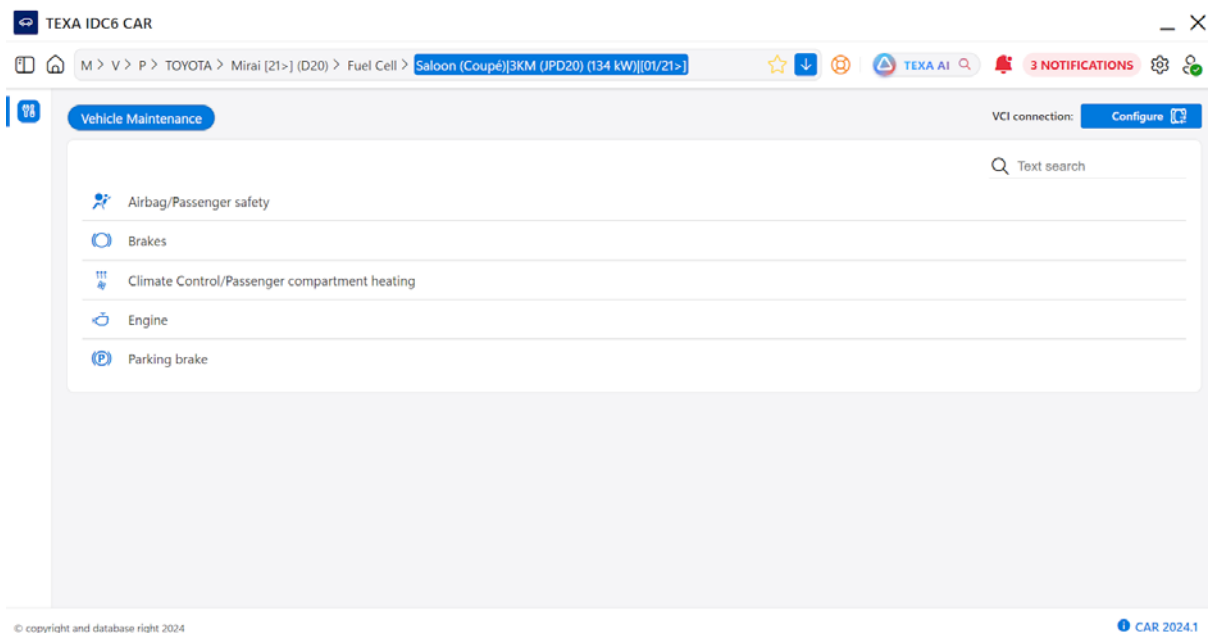

4. Select the device.

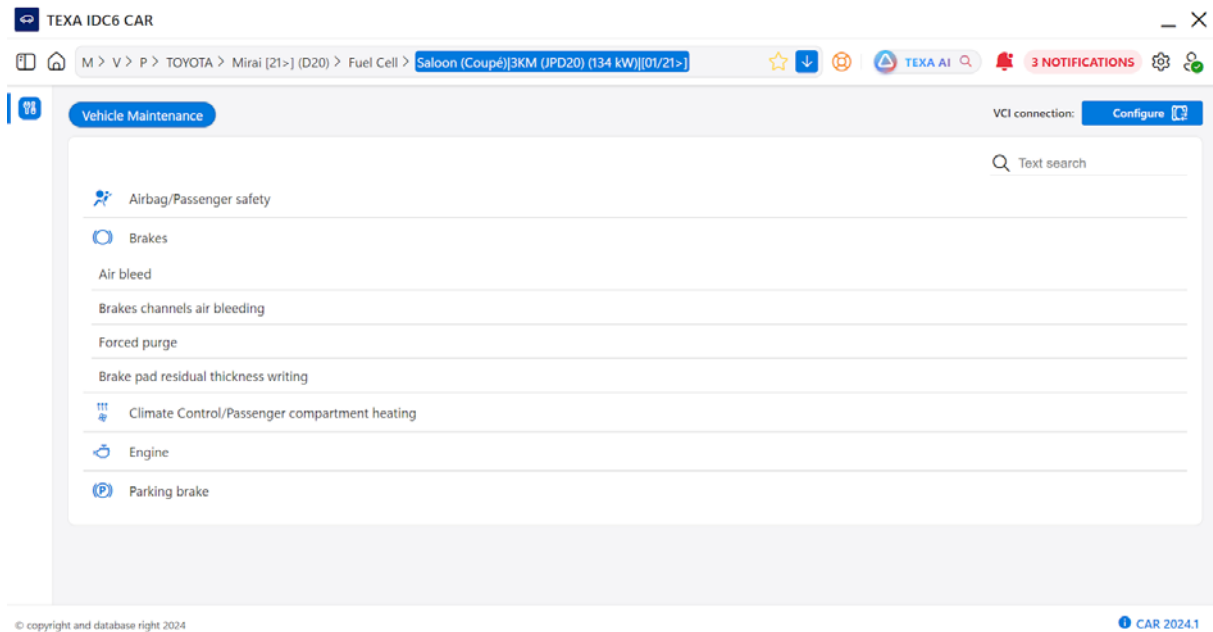

5. Select the desired variant.

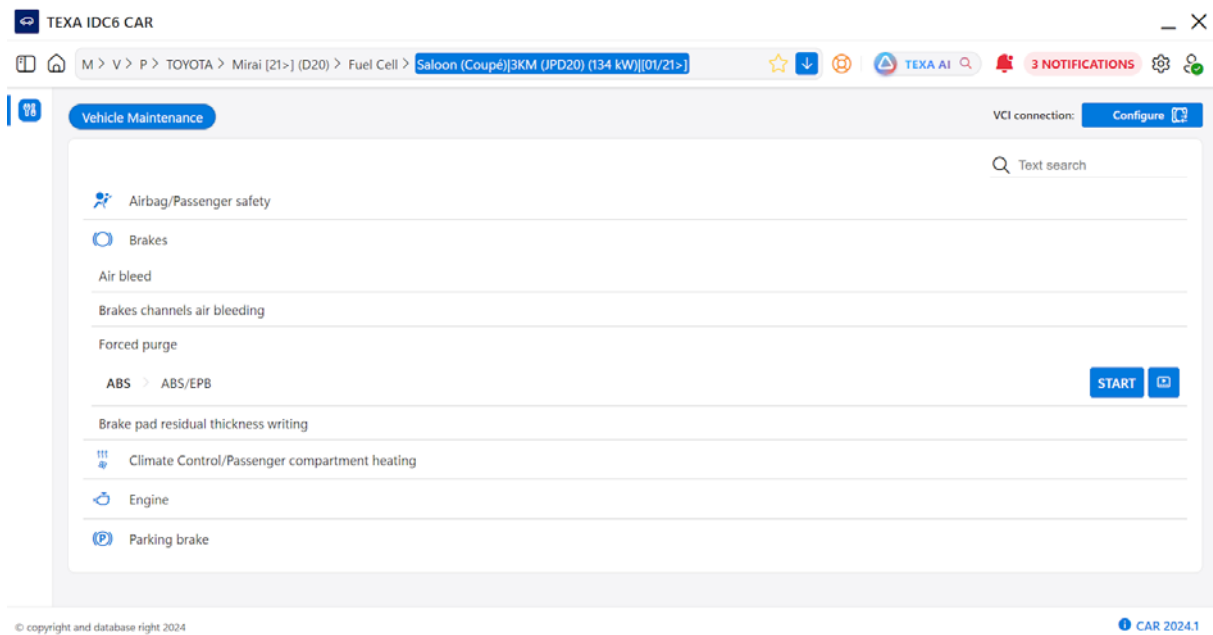

6. Press: **START**

A guided procedure is started.

7. Follow the instructions that appear on screen.

29 ADJUSTMENTS AND CODINGS



This section allows accessing the ADJUSTMENTS function for the specific component selected. Proceed as follows:

1. Press:

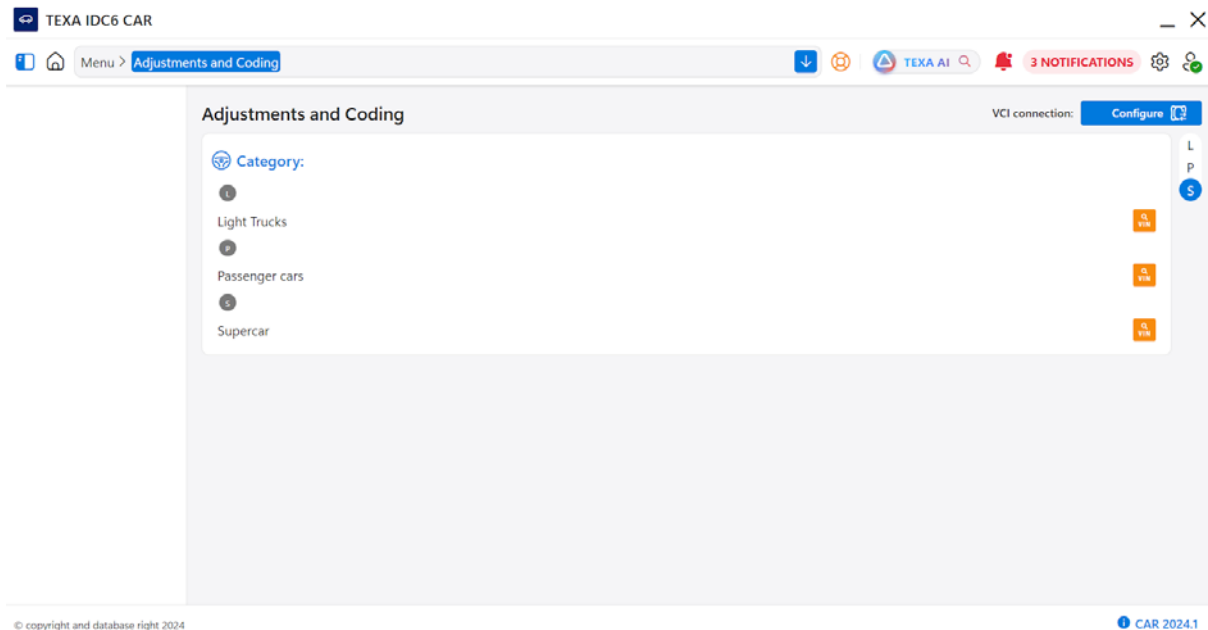

2. Carry out a complete selection.

3. Select the type of system.

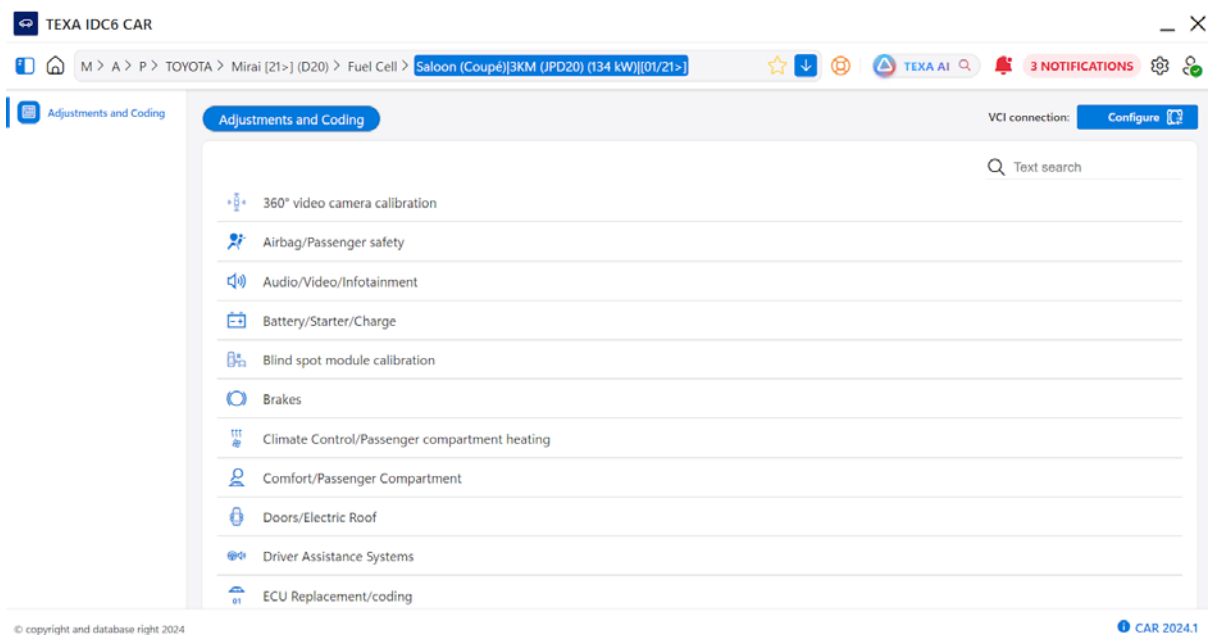

4. Select the device.

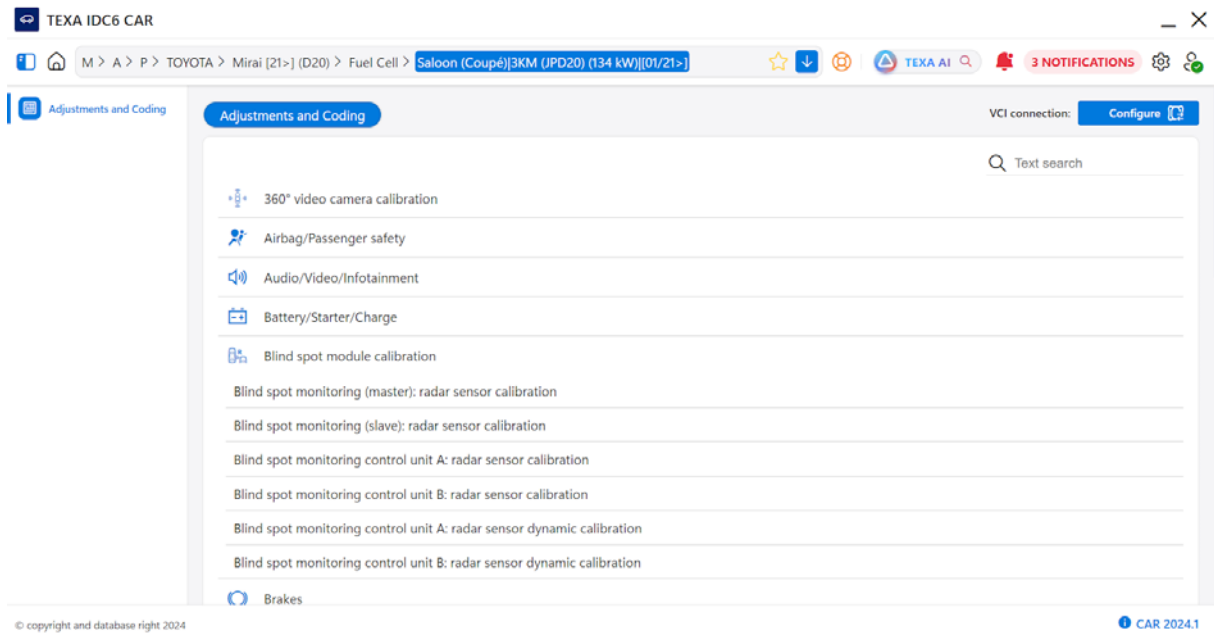

5. Select the desired variant.

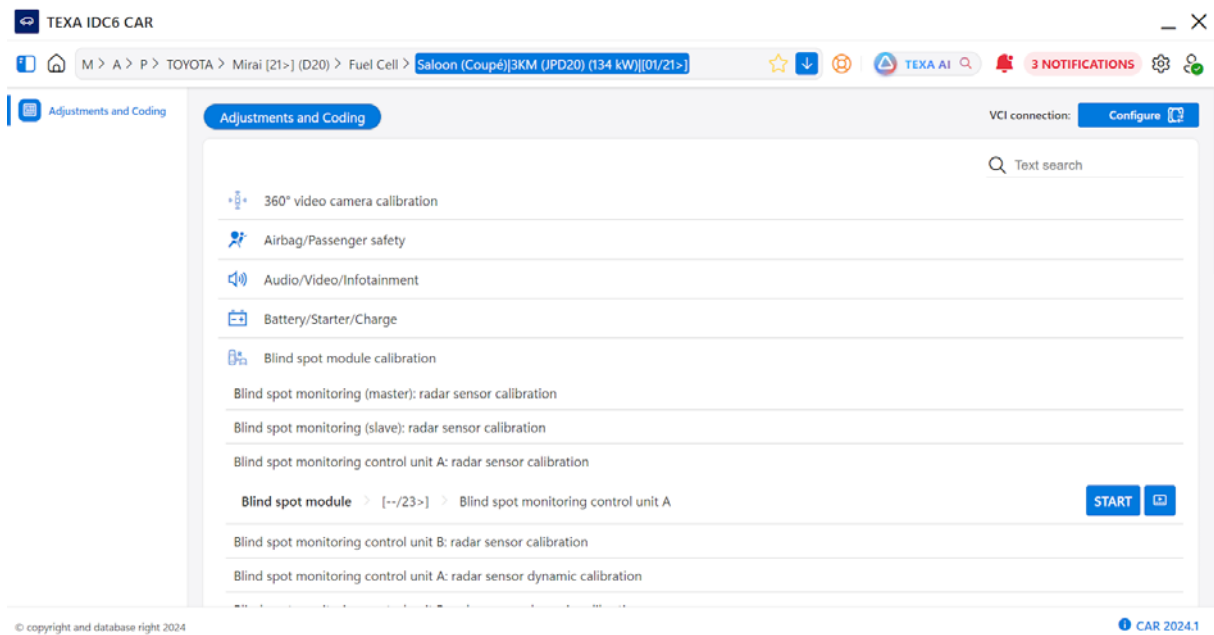

6. Press: **START**

A guided procedure is started.

7. Follow the instructions that appear on screen.

30 ACTIVATION TESTS



This section allows accessing the ACTIVATIONS function for the specific component selected. Proceed as follows:

1. Press:

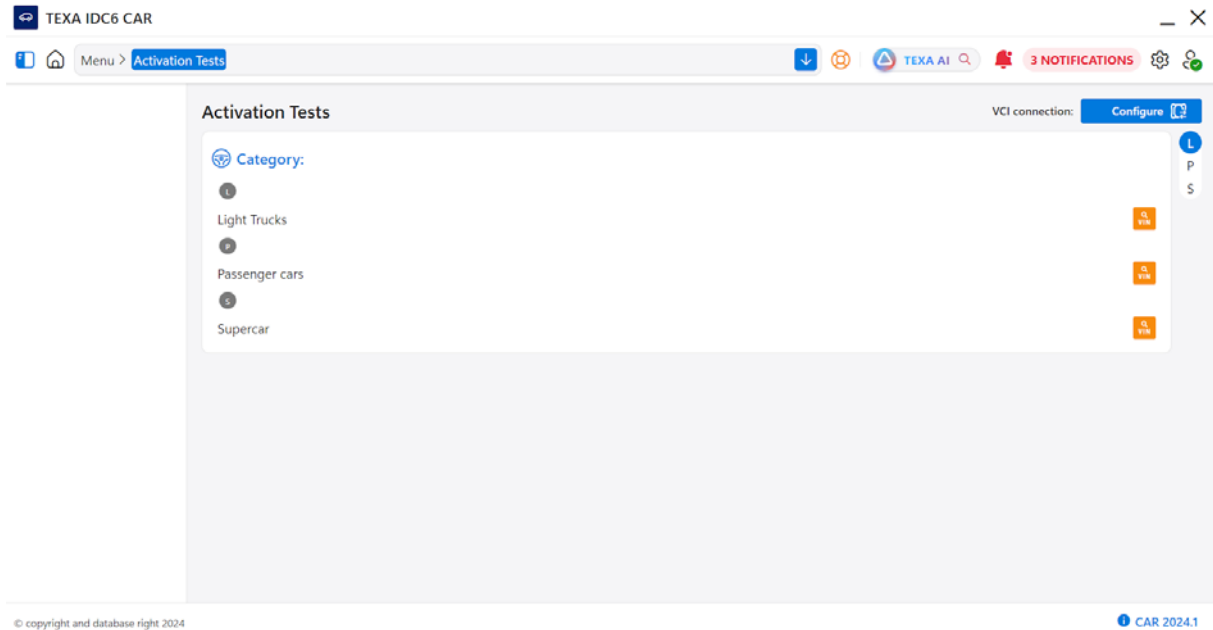

2. Carry out a complete selection.

3. Select the type of system.

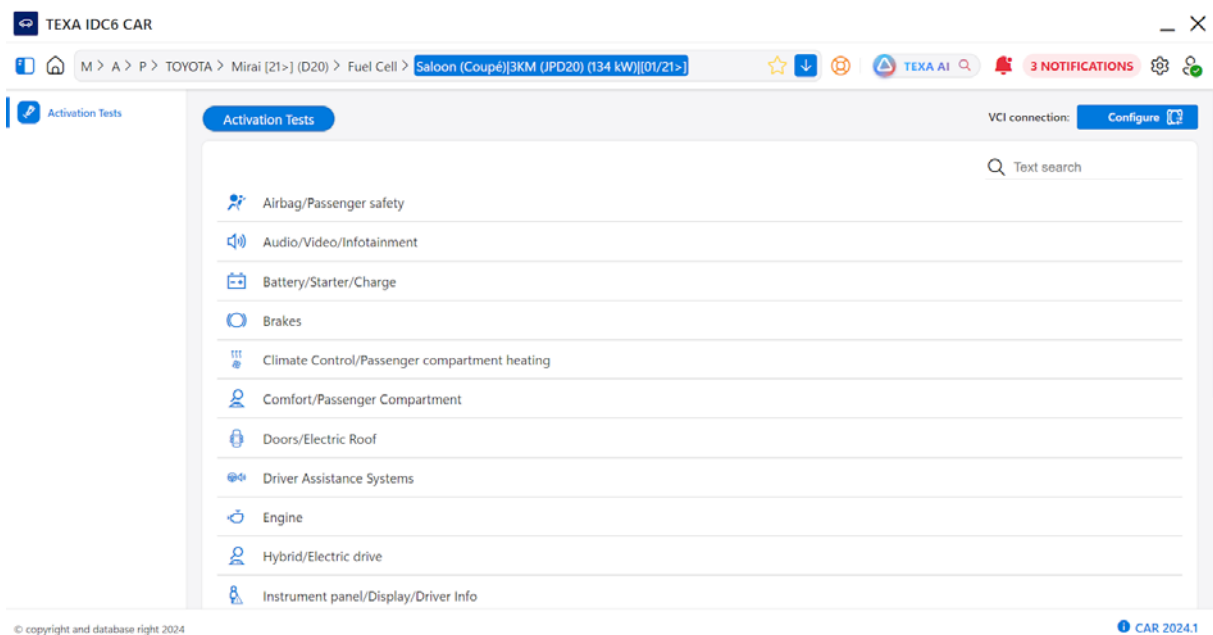

4. Select the device.

TEXA IDC6 CAR

M > A > P > TOYOTA > Mirai [21>] (D20) > Fuel Cell > Saloon (Coupé)[3KM (JPD20) (134 kW)][01/21>]

Activation Tests

VCI connection: [Configure](#)

Text search

- Airbag/Passenger safety
- Audio/Video/Infotainment
- Battery/Starter/Charge
- Hybrid battery cooling system
- Battery's magnetic valve
- Battery cooling fan
- IGP (Ignition power) signal
- Battery heater relay
- Secondary battery module backup relay
- Secondary battery module protection relay
- High voltage battery coolant cooling solenoid valve command
- High voltage battery coolant cooling command

© copyright and database right 2024

CAR 2024.1

5. Select the desired variant.

TEXA IDC6 CAR

M > A > P > TOYOTA > Mirai [21>] (D20) > Fuel Cell > Saloon (Coupé)[3KM (JPD20) (134 kW)][01/21>]

Activation Tests

VCI connection: [Configure](#)

Text search

- Airbag/Passenger safety
- Audio/Video/Infotainment
- Battery/Starter/Charge
- Hybrid battery cooling system
- Battery's magnetic valve
- Battery cooling fan
- Hybrid battery
- IGP (Ignition power) signal
- Battery heater relay
- Secondary battery module backup relay
- Secondary battery module protection relay
- High voltage battery coolant cooling solenoid valve command

© copyright and database right 2024

CAR 2024.1

6. Press: **START**

A guided procedure is started.

7. Follow the instructions that appear on screen.

31 EOBD PROTOCOL / OBD STANDARD PROTOCOL



The **EOBD Protocol** and **OBD Standard Protocol** functions allow carrying out a basic diagnosis using the OBD standard protocols (each function for the environments it is available in).

The modes and procedures are the same for both functions.

INFORMATION



The OBD Standard Protocol function is supported only by the vehicles that comply with Euro 4 and higher emission standards.

Proceed as follows:

1. Press:  / 

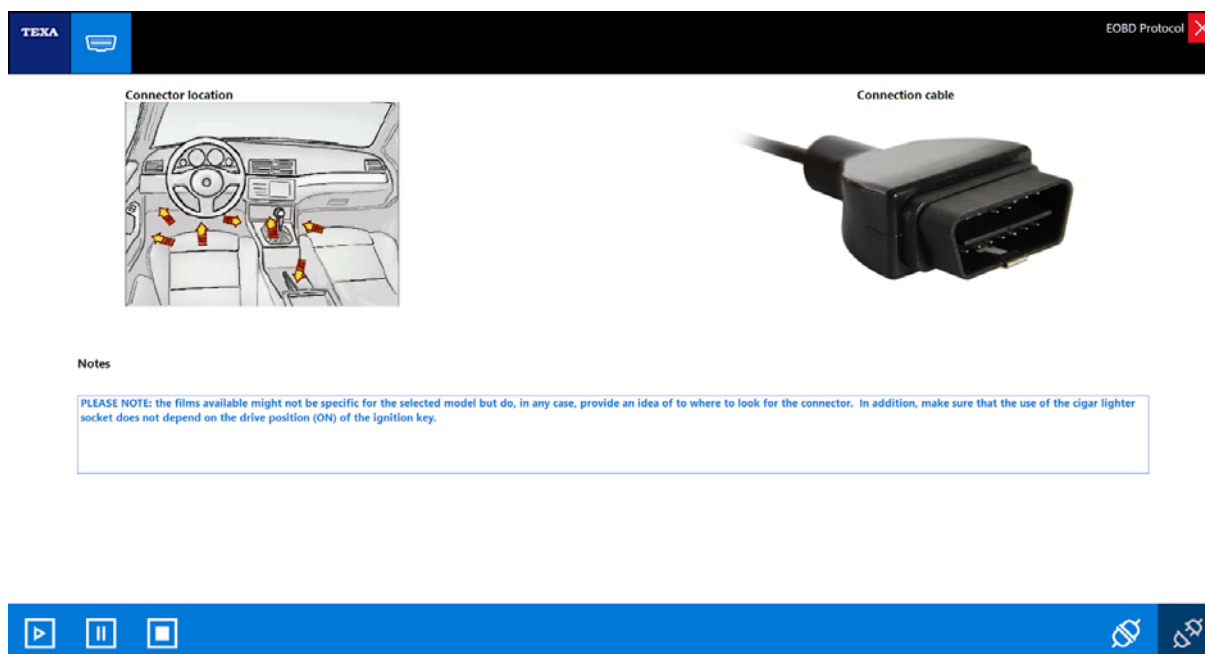
The main screen is displayed.



Icon	Name	Description
	Connect	Allows you to connect the device to the control unit.
	Disconnect	Allows you to disconnect the device from the control unit.

The screen provides the following information:

- a video illustrating how to access the diagnostic socket;
- an image and the code of the diagnostic cable that must be used.

2. Press: 

After the connection, the **Vehicle information** screen is displayed.

The screenshot shows the 'Vehicle information' screen in the TEXA software. At the top, there is a header with the TEXA logo and 'EOBD Protocol' with a close button. Below the header, the screen displays the following information:

Vehicle information
Communication protocol
ISO 14230-4

ECU	Type	OBD requirements to which vehicle is designed
\$10	Engine	EOBD (Europe)

Readiness test

ECU	Readiness test
\$10	Not all supported on-board system readiness tests have been completed.

ECU	Bank - Sensor	Lambda probes
\$10	Bank 1 - Sensor 1	Two-step oxygen sensor
\$10	Bank 1 - Sensor 2	Two-step oxygen sensor

OBDDiagnose
On-board system readiness tests evaluation

OBDDiagnose
Diagnostic trouble codes and MIL status evaluation

Mode \$01
Request for current powertrain diagnostic data

Mode \$02
Request for powertrain freeze frame data

The screen provides the following information:

1. **Communication protocol implemented by the vehicle.**
 - *ISO 9141-2;*
 - *ISO 14230-4 (Keyword 200);*
 - *ISO 15765-4 (CAN);*
 - ...
2. **Control unit address**
3. **Type of control unit**
4. **Position of the probes installed on the vehicle**
 - *bank number;*
 - *number that identifies the location of the probe within the bank.*
5. **Vehicle OBD status**
 - *OBD and OBD II;*
 - *not OBD compliant;*
 - *EOBD (Europe);*
 - ...
6. **Status of the readiness tests**
7. **Probe type**
 - *switching probe (also called jump);*
 - *wideband probe (also called wide-range or broadband) under voltage;*
 - *wideband probe (also called wide-range or broadband) under current.*
 - ...

If the vehicle's **OBD status** is **Not OBD compliant**, the software allows carrying out the diagnosis anyway but the results may not be reliable.

However, this information is useful to understand unexpected results or measurements that not meet any integrity restriction.

NOTICE

A vehicle that is not compliant with the OBD specifications may not support certain software functions or may not respond to polls and tests in a standard way.









From the **Vehicle information** screen you can access the **modes**.



The **modes** are ways of interrogating the control units that allow acquiring specific diagnostic data.

INFORMATION

The modes that can be selected depend on the services provided by the control unit of the vehicle being tested.

The modes available are:

Icon	Name - Description
	OBD diagnosis: Evaluation of the on-board system readiness tests It allows checking the vehicle's efficiency by evaluating the readiness tests .
	OBD diagnosis: Evaluation of diagnostic trouble codes and MIL status It allows checking the vehicle's efficiency by evaluating the status of the MIL and of the DTC (Diagnostic Trouble Codes) detected.
	Mode \$01: Request for current powertrain diagnostic data It allows viewing the current data available.
	Mode \$02: Request for powertrain freeze frame data It allows viewing the freeze frames available.
	Mode \$03: Request for powertrain emissions-related diagnostic trouble codes It allows viewing the DTCs detected.
	Service \$04: Clear/reset emissions-related diagnostic information It allows deleting all the diagnostic information available. The vehicle's control units respond to this service when the ignition key is turned to the ON position and the engine is off. For technical and / or safety reasons, in certain conditions, some control units may not respond to this service.
	Mode \$05: Request for oxygen sensor monitor test results It allows viewing the results of the monitoring tests related to the oxygen sensors .
	Mode \$06: Request for on-board monitoring tests carried out on specific monitored systems It allows viewing the results of the monitoring tests related to systems / components that are not continuously monitored, such as the EGR valve or the evaporation system. Furthermore, it can be used to view the results of the tests on the oxygen sensors instead of Mode \$05 .
	Mode \$07: Request for emissions-related diagnostic trouble codes detected during current driving cycle or driving cycle just completed It allows viewing any DTC detected during the last driving cycle . The term driving cycle refers to a period of engine operation in which the vehicle reaches, for example, given values for specific parameters defined by the manufacturer. The information provided is useful after repairing a vehicle, to observe how its systems operate after a single driving cycle.

	<p>Mode \$08: Request for control of an on-board system, test or component</p> <p>It allows checking the operation of a system, a test or a component on the vehicle.</p> <p>The possible uses of this mode are:</p> <ul style="list-style-type: none"> • <i>activate a system / test / component;</i> • <i>deactivate a system / test / component;</i> • <i>activate a system / test / component for n seconds; run a test for n seconds.</i> <p>The possible results of this mode are:</p> <ul style="list-style-type: none"> • <i>display of the system's status;</i> • <i>display of the test result.</i>
	<p>Mode \$09: Request for vehicle information</p> <p>It allows viewing information related to the vehicle such as the VIN (Vehicle Identification Number), CALID (Calibration ID), CVN (Calibration Verification Number) and other information related to the vehicle's performances.</p>

INFORMATION

The parameters may be organised in groups or subsets if they have similar characteristics.



31.1 OBD diagnosis: Evaluation of the on-board system readiness tests

This mode allows checking the vehicle's efficiency by evaluating the readiness tests. Proceed as follows:

1. Press: 

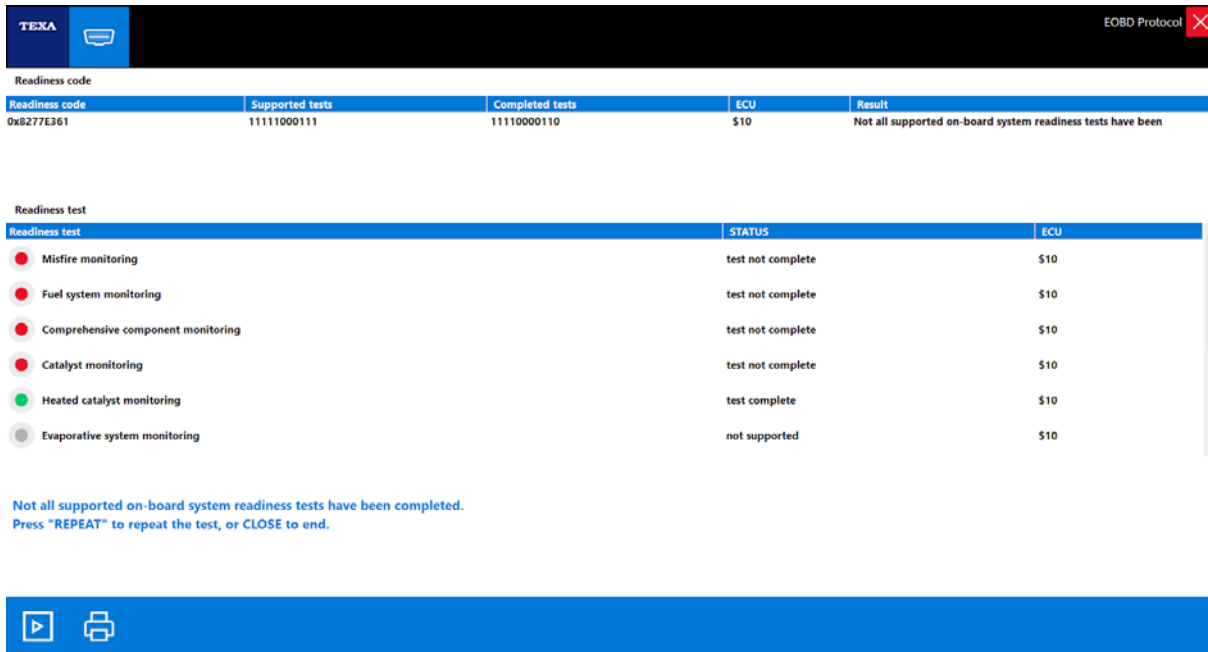
The evaluation screen is displayed.





Icon	Name	Description
	Repeat	Allows you to repeat the data acquisition.
	Print	It allows printing a report of the test that has been performed.

The screen provides the following information:

- **Response message data in hexadecimal format** (*readiness code*);
- **Bit-train representing the services supported** (*0 if the service is not supported and 1 if the service is supported*);
- **Bit-train representing the services completed** (*0 if the service is complete or not applicable and 1 if the service is not complete*);
- **Control unit address;**
- **Overall result deriving from the evaluation of the readiness tests;**
- **Full description of the readiness test;**
- **Readiness test status.**

Below there is a legend of the symbols used to describe the status of the readiness tests.

Icon	Name	Description
	Green LED	Symbol used to indicate that the related readiness test is complete.
	Red LED	Symbol used to indicate that the related readiness test is not complete.
	Grey LED	Symbol used to indicate that the related readiness test is not supported.

31.2 OBD diagnosis: Evaluation of diagnostic trouble codes and MIL status

This service carries out the acquisition of the status of the **MIL** and of the number of **DTCs** (Diagnostic Trouble Codes).

The service is carried out via the diagnostic device using the request **Mode\$01 PID\$01** (Data Byte A).

The acquisition of diagnostic trouble codes is carried out using the request **Mode \$03**.

Proceed as follows:

1. Press: 

The evaluation screen is displayed.

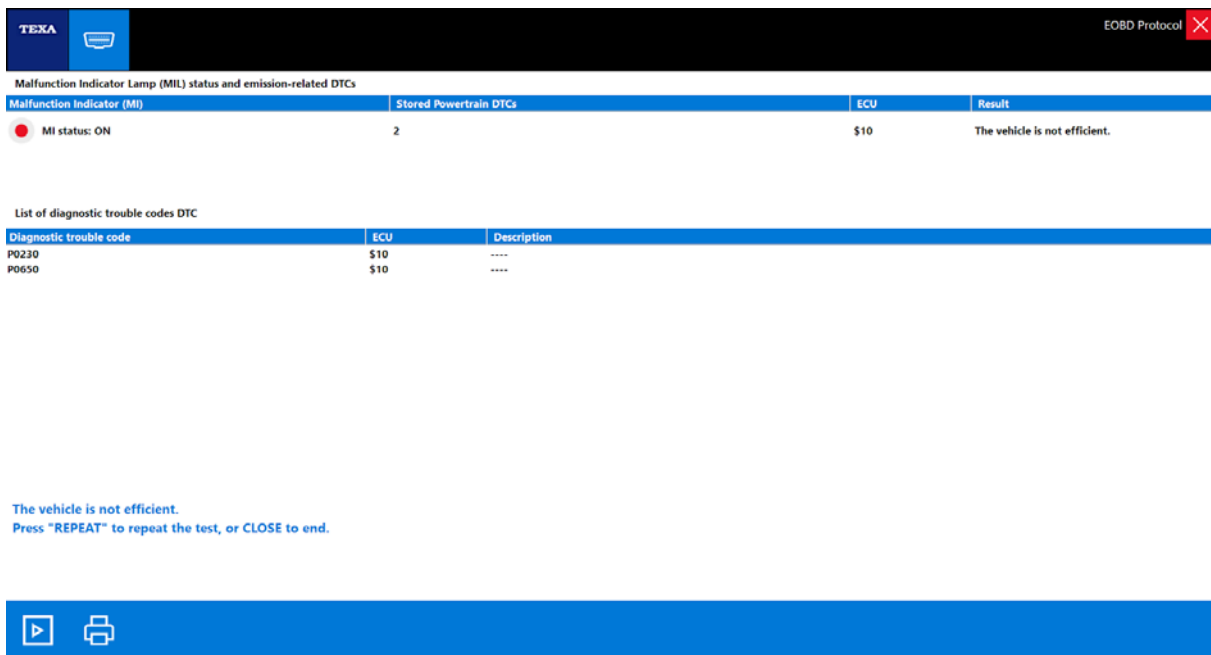

POSITIVE OUTCOME: the vehicle is only considered efficient if all the control units indicate that the MIL is off and that there are no errors.

NEGATIVE OUTCOME: the vehicle is not considered efficient if at least one of the control units indicates that the MIL is on or if a control unit detects there is an error stored.

The screen provides the following information:

- *Status of the **MIL** (Malfunction Indicator Light).*
- *Number of **DTCs** stored.*
- *Control unit address.*
- *Overall result deriving from the evaluation of the readiness tests.*
- *Diagnostic Trouble Code (**DTC**).*
- *Full description of the **DTC**.*

31.3 Mode \$01: Request for current powertrain diagnostic data

This service allows accessing the **current** parameters and statuses available in the control units. A parameter or a status is defined as **actual** when it is acquired during diagnosis.

The device polls the control units to know which parameters/statuses are available for the acquisition.

Proceed as follows:

1. Press: 

A list of the available parameters is displayed.

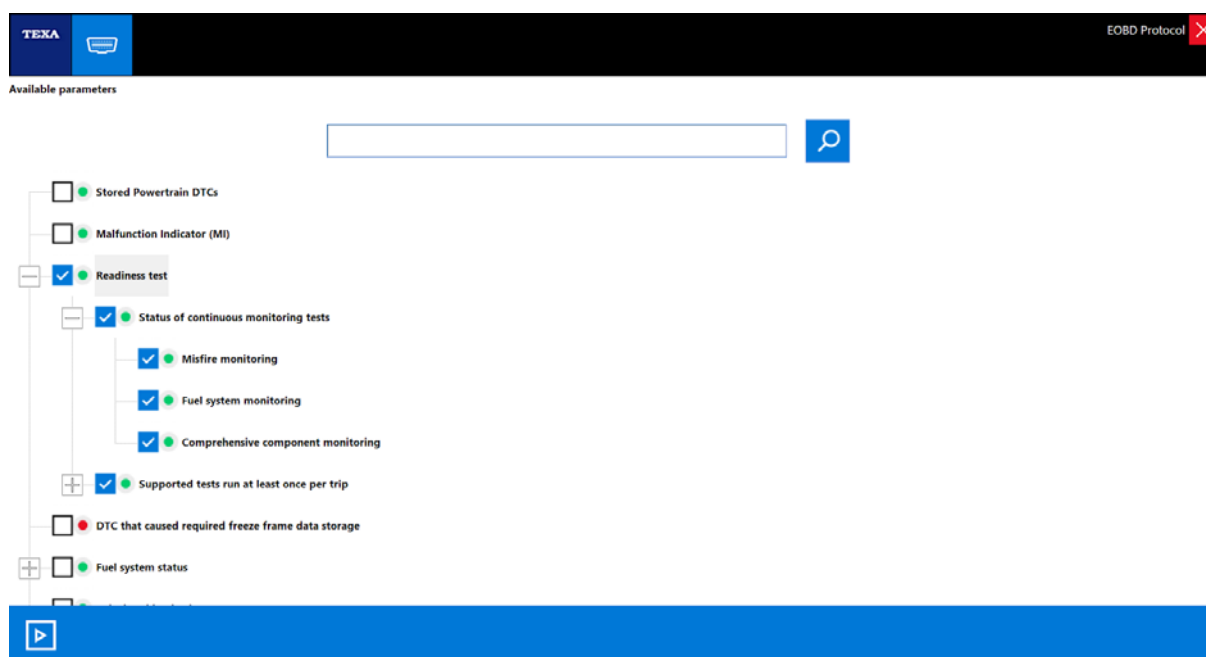

2. Select the desired information.



Icon	Name	Description
	Poll	Allows you to launch the data acquisition.

Below there is a legend of the symbols used to describe the status of data or of a node that represents a group of data.

Icon	Name	Description
	Green LED	<p>Symbol used for both a single data element and a node that gathers a set of data:</p> <ul style="list-style-type: none"> if it is a single data element this means that the current data is supported by at least one of the control units in the vehicle; if it is a node that gathers a set of data this means that all the data elements that it gathers are supported.

	Red LED	<p>Symbol used for both a single data element and a node that gathers a set of data:</p> <ul style="list-style-type: none"> • <i>if it is a single data element this means that the current data is not supported by any control unit in the vehicle;</i> • <i>if it is a node that gathers a set of data this means that none of the elements that it gathers is supported.</i>
	Yellow LED	<p>Symbol used only to represent the status of a node that gathers a set of data. It means that the node gathers both supported and non-supported data.</p>
	Question mark	<p>Symbol used for both a single data element and a node that gathers a set of data:</p> <ul style="list-style-type: none"> • <i>if it is a single data element this means that it is impossible to determine whether the current data is supported or not;</i> • <i>if it is a node that gathers a set of data this means that among the data elements that it gathers there is at least one element for which it is impossible to determine whether it is supported or not.</i>

INFORMATION

This table is applicable to all the modes described below (Mode \$02 ... Mode \$09).

3. Press: 

The data relating to the selected parameters is displayed.



The screenshot shows a diagnostic tool interface with a black header bar containing 'TEXA' on the left and 'EOBD Protocol' with a red close button on the right. Below the header, the text 'Evaluating parameters' is visible. The main content is a table with three columns: 'Description', 'ECU', and 'Value'.

Description	ECU	Value
Misfire monitoring	\$10	test not complete
Fuel system monitoring	\$10	test not complete
Comprehensive component monitoring	\$10	test not complete
Catalyst monitoring	\$10	test not complete
Heated catalyst monitoring	\$10	test complete
Evaporative system monitoring	\$10	not supported
Secondary air system monitoring	\$10	not supported
Oxygen sensor monitoring	\$10	test not complete
Oxygen sensor heater monitoring	\$10	test not complete
EGR and/or VVT system monitoring	\$10	test complete

The screen provides the following information:

- *data description;*
- *control unit address;*
- *data value.*

31.4 Mode \$02: Request for powertrain freeze frame data

This service allows accessing the **freeze frame** parameters and statuses available in the control units.

A parameter or status is defined as **freeze-frame** when it is acquired at the time the error occurs and remains over time.

The device polls the control units to know which parameters/statuses are available for the acquisition.

Proceed as follows:

1. Press: 

A list of the available parameters is displayed.
2. Select the desired information.

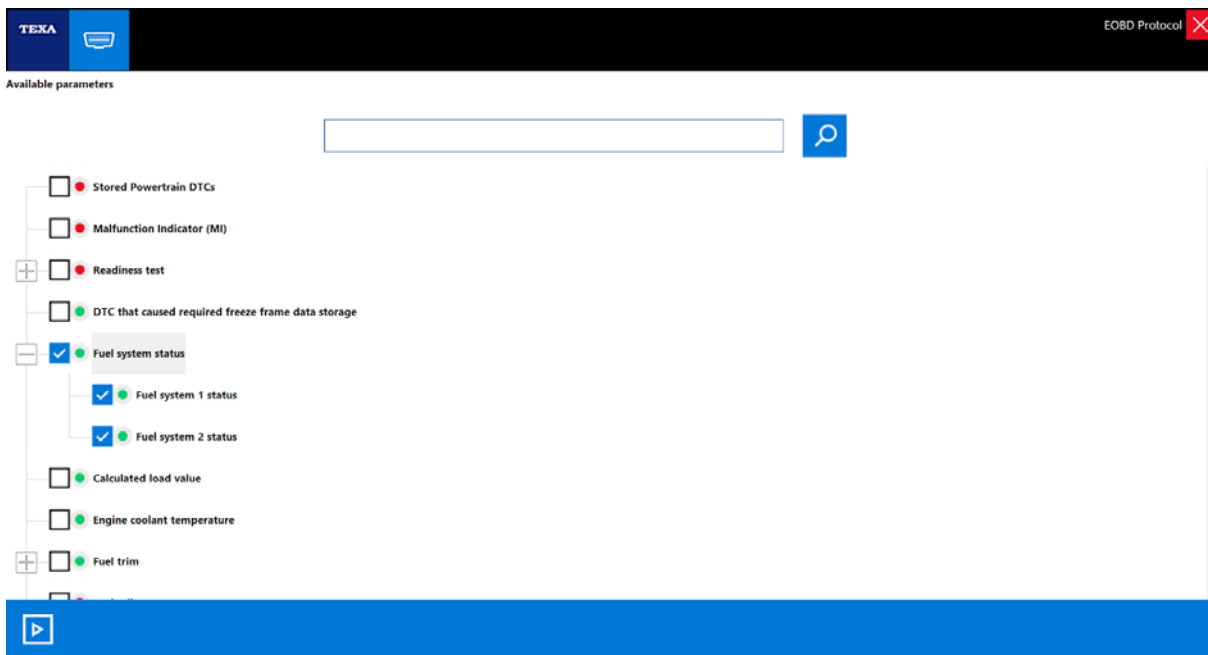

Icon	Name	Description
	Poll	Allows you to launch the data acquisition.

3. Press: 

The data relating to the selected parameters is displayed.



The screenshot shows a software interface with a black header bar. On the left, there is a blue logo with the text 'TEXA' and a white icon of a car. On the right, the text 'EOBD Protocol' is displayed next to a red close button. Below the header, the text 'Evaluating parameters' is visible. The main content is a table with a blue header row and two data rows. The table columns are 'Description', 'ECU', 'Frame', and 'Value'. The first data row shows 'Fuel system 1 status' with ECU '---', Frame '00', and Value '---'. The second data row shows 'Fuel system 2 status' with ECU '---', Frame '00', and Value '---'.

Description	ECU	Frame	Value
Fuel system 1 status	---	00	---
Fuel system 2 status	---	00	---

The screen provides the following information:

- *Description of the parameter.*
- *Control unit address.*
- *Number of the frame in which the data is contained.*
- *Value of the parameter.*

31.5 Mode \$03: Request for powertrain emissions-related diagnostic trouble codes

This service allows retrieving the **DTCs** (Diagnostic Trouble Codes) stored in the control units.



Proceed as follows:

1. Press:  (DTC)

A list of the available parameters is displayed.



Diagnostic trouble code	ECU	Description
P0230	\$10	---
P0650	\$10	---

Icon	Name	Description
	Poll	Allows you to launch the data acquisition.
	Stop	Allows you to stop the data acquisition.

INFORMATION

If the DTCs that appear are standard (not dependent on the manufacturer), the corresponding description is also displayed.

The screen provides the following information:

- *Diagnostic Trouble Code (DTC).*
- *Control unit address.*
- *Description of the DTC.*

INFORMATION

You can select the continuous data reading by pressing: Repeat the reading of values cyclically

31.6 Service \$04: Clear/reset emissions-related diagnostic information

This service allows clearing all the diagnosis information in the control units.

The control units of the vehicle respond to this service when the **ignition key is turned ON** and the engine is off.

It is possible to clear:

- *Status of the MIL and the number of the diagnostic trouble codes.*
- *I/M (inspection/maintenance) readiness bit.*
- **DTC's confirmed.**
- **DTC's pending.**
- *Diagnostic trouble code for the freeze-frame data.*
- *Freeze-frame data.*
- *Data relative to the oxygen sensor tests.*
- *Status of the system monitoring tests.*
- *Results of the on-board monitoring tests.*
- *Distance run by the vehicle with the MIL on.*
- *Number of warm-ups after the **DTCs** have been cleared.*
- *Distance run by the vehicle after the **DTCs** have been cleared.*
- *Time elapsed with the engine running with the MIL on.*
- *Time elapsed since the **DTCs** have last been cleared.*

NOTICE

Using this service, other information specified by the manufacturer may be cleared.

INFORMATION



In some cases, for technical or safety reasons, certain control units may not respond to this service.

Proceed as follows:

1. Press: 

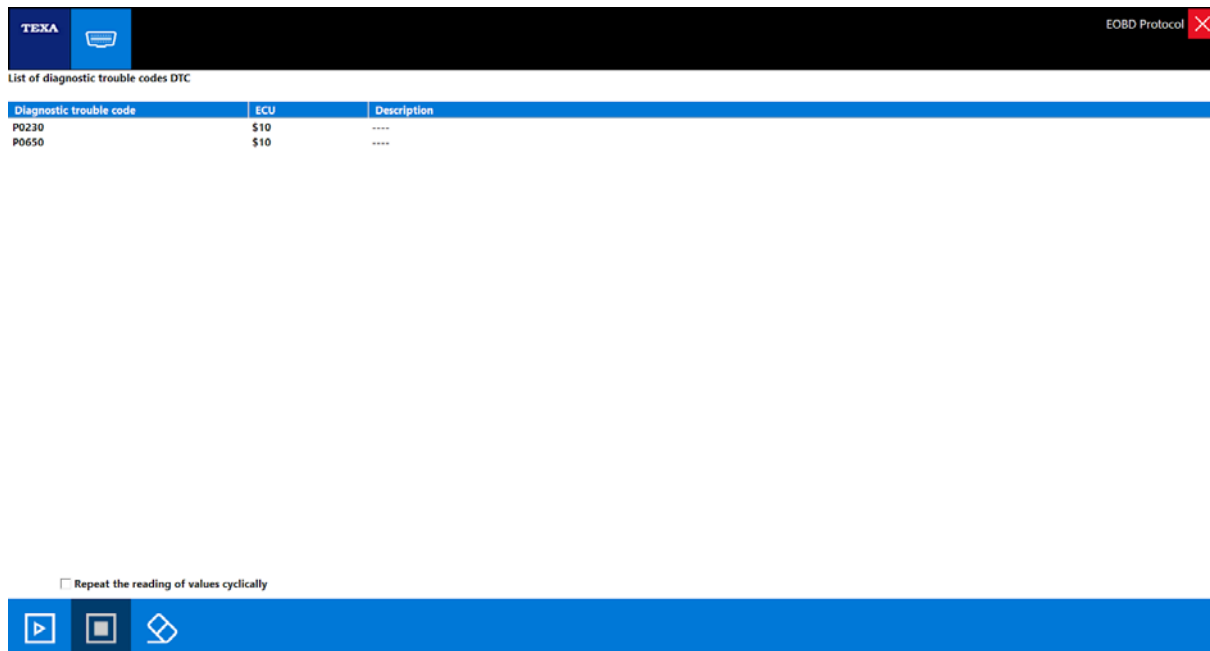
The screen with the list of **DTCs** is displayed.



Icon	Name	Description
	Poll	Allows you to launch the data acquisition.
	Stop	Allows you to stop the data acquisition.
	Reset	It allows clearing all the diagnostic information within the control units.

The screen provides the following information:

- *Diagnostic Trouble Code (DTC).*
- *Control unit address.*
- *Description of the DTC.*

INFORMATION You can select the continuous data reading by pressing: Repeat the reading of values cyclically

31.7 Mode \$05: Request for oxygen sensor monitor test results

This service allows viewing the results of the oxygen sensor monitor tests.

INFORMATION

*This service is not supported by the protocol ISO 15765-4 (CAN).
When operating on control units that implement the protocol ISO 15765-4 (CAN), these results can be viewed using Mode \$06.*

Proceed as follows:

1. Press:  (oxygen sensors)
The list of tests is displayed.
2. Select the desired parameters.

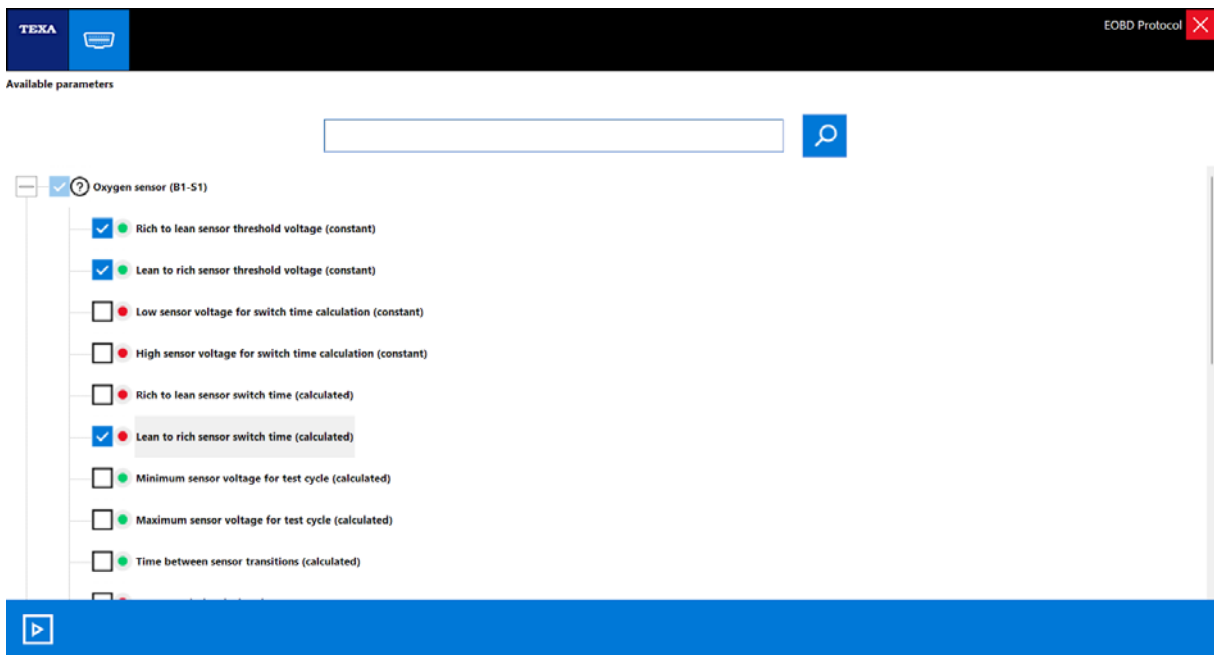

Icon	Name	Description
	Poll	Allows you to launch the data acquisition.

3. Press: 

The data relating to the selected parameters is displayed.

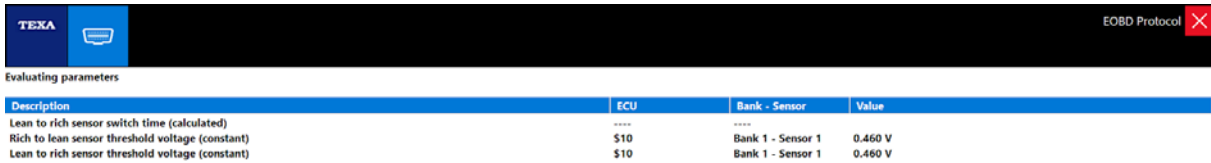

The screenshot shows a software interface with a black header bar containing the 'TEXA' logo and 'EOBD Protocol' with a close button. Below the header, the text 'Evaluating parameters' is visible. A table with a blue header and white body displays the following data:

Description	ECU	Bank - Sensor	Value
Lean to rich sensor switch time (calculated)	----	----	
Rich to lean sensor threshold voltage (constant)	\$10	Bank 1 - Sensor 1	0.460 V
Lean to rich sensor threshold voltage (constant)	\$10	Bank 1 - Sensor 1	0.460 V

The screen provides the following information:

- *Description of the result*
- *Control unit address*
- *Sensor position*
- *Detected value*
- *Minimum limit detected*
- *Maximum limit detected*

31.8 Mode \$06: Request for on-board monitoring tests carried out on specific monitored systems

This service allows viewing the on-board monitoring test results relating to specific components/ systems that are not continuously monitored, for example the catalyst or the EVAP system.

Proceed as follows:

1. Press: 

The list of tests is displayed.
2. Select the desired parameters.

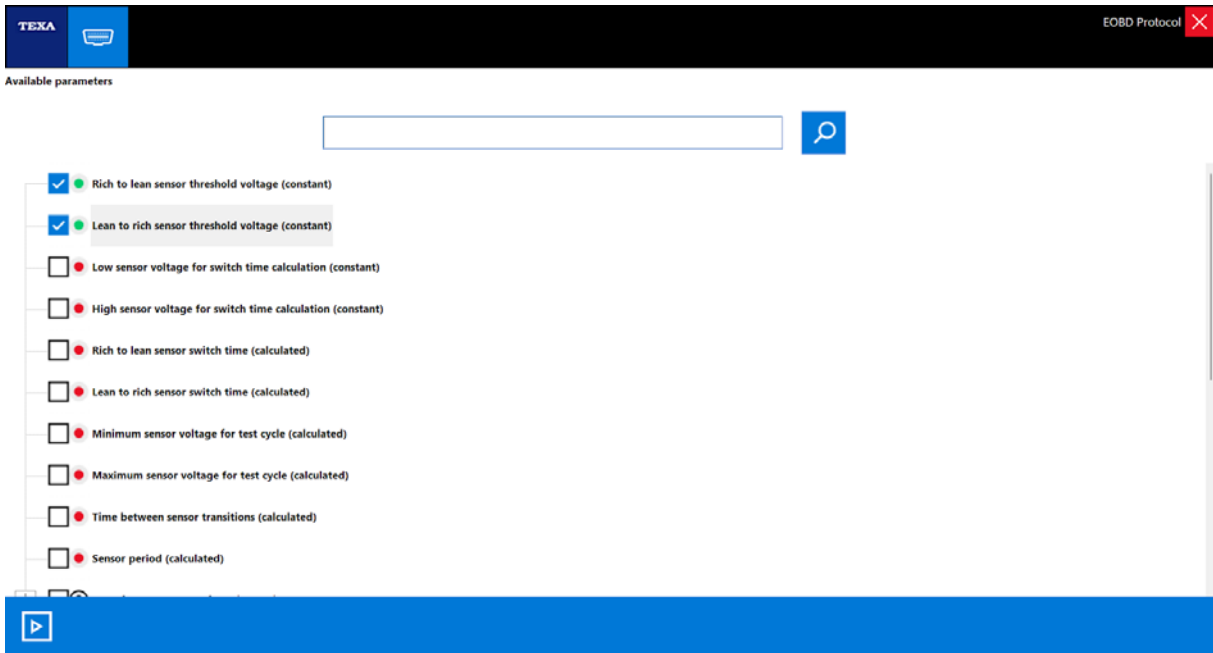

Icon	Name	Description
	Poll	Allows you to launch the data acquisition.

3. Press: 

The data relating to the selected parameters is displayed.



The screenshot shows a software interface with a black header bar. On the left, there is a blue logo with the text 'TEXA' and a white icon of a car. On the right, the text 'EOBD Protocol' is displayed next to a red 'X' icon. Below the header, the text 'Evaluating parameters' is visible. A table with a blue header and white body is shown. The table has four columns: 'Description', 'ECU', 'Component ID', and 'Minimum value'. The first two rows of the table contain data, while the third row is empty.

Description	ECU	Component ID	Minimum value
Rich to lean sensor threshold voltage (constant)	---	---	---
Lean to rich sensor threshold voltage (constant)	---	---	---

The screen provides the following information:

- *Description of the result.*
- *Control unit address.*
- *Component ID.*
- *Detected value.*
- *Minimum limit detected.*
- *Maximum limit detected.*

31.9 Mode \$07: Request for emissions-related diagnostic trouble codes detected during current driving cycle or driving cycle just completed

This service allows viewing the on-board monitoring test results for specific continuously monitored systems.

This information is particularly useful after a vehicle repair, to monitor the operation of the vehicle systems after a single driving cycle.

The term “**driving cycle**” refers to a period of engine operation in which the vehicle reaches, for instance, specific values for specific parameters defined by the manufacturer.

If the test fails during the driving cycle the **DTC** associated to that test will be indicated.

The results of the tests indicated by this service do not necessarily indicate a faulty component or system.

If the results of the tests indicate a fault after a second driving cycle, the **MIL** will come on and the **DTC** is stored and provided by the **Mode \$03** service.

If after the second driving cycle the results of the tests indicate a fault, the **MIL** will come on and the **DTC** is set in the **Mode \$03**.



Mode \$03 indicates the faulty component or system.

Proceed as follows:

1. Press: 

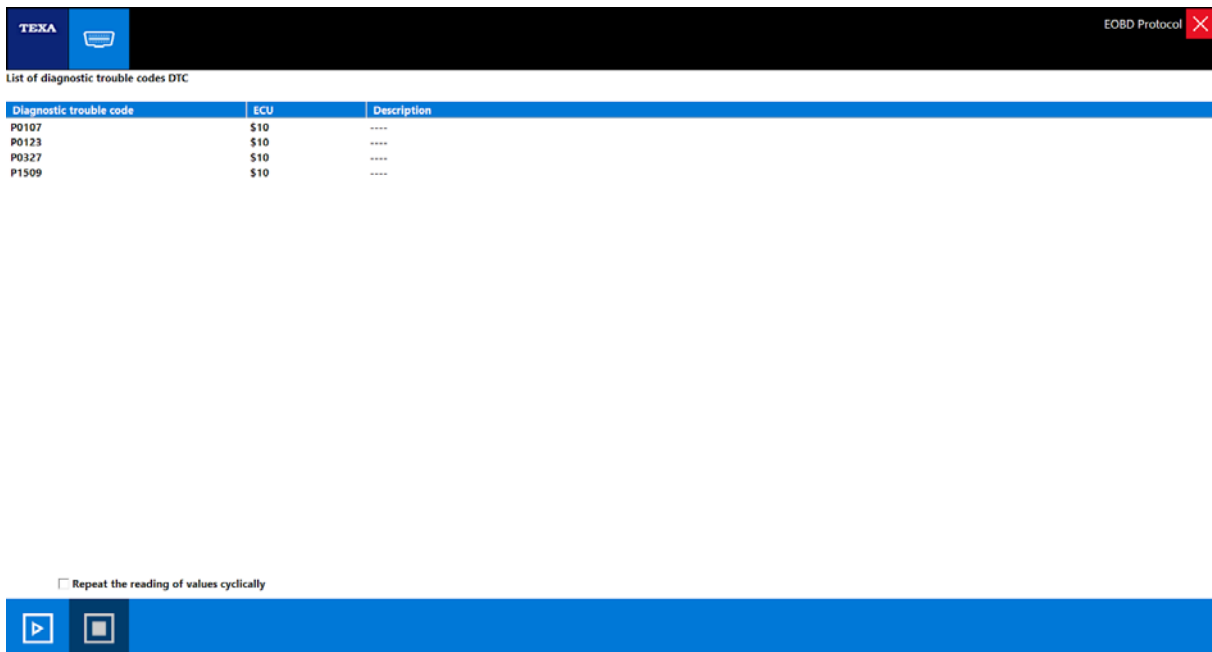
The screen with the list of **DTCs** is displayed.



Icon	Name	Description
	Poll	Allows you to launch the data acquisition.
	Stop	Allows you to stop the data acquisition.

The screen provides the following information:

- *Diagnostic Trouble Code (DTC).*

- *Control unit address.*
- *Description of the **DTC**.*

INFORMATION

You can select the continuous data reading by pressing: Repeat the reading of values cyclically

31.10 Mode \$08: Request for control of an on-board system, test or component

This function allows you to control the operation of an on-board system, test or component.

Proceed as follows:

1. Press: 
A list of the available parameters is displayed.
2. Select the desired parameters.



Icon	Name	Description
	Poll	Allows you to launch the data acquisition.

3. Press: 

The data relating to the selected parameters is displayed.



The screenshot shows a software interface with a black header bar. On the left, there is a blue logo with the text 'TEXA' and a white icon of a car. On the right, the text 'EOBD Protocol' is displayed next to a red 'X' icon. Below the header, the text 'Evaluating parameters' is visible. A table with three columns is shown: 'Description', 'ECU', and 'Value'. The first row of data contains 'Evaporative system leak test', '----', and '----'.

Description	ECU	Value
Evaporative system leak test	----	----

The screen provides the following information:

- *Description of the parameter.*
- *Control unit address.*
- *Value of the parameter.*

31.11 Mode \$09: Request for vehicle information

This service allows you to view specific vehicle information, for instance the vehicle identification number (VIN) or the calibration ID.

Proceed as follows:

1. Press: 
A list of the available parameters is displayed.
2. Select the desired parameters.

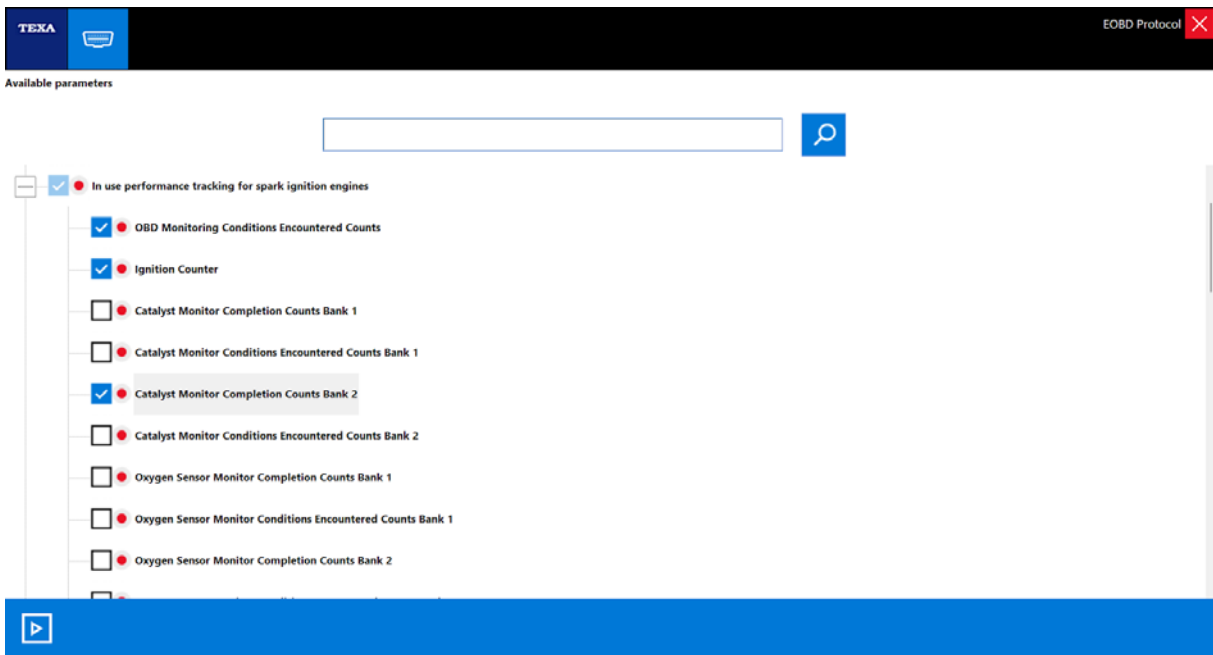

Icon	Name	Description
	Poll	Allows you to launch the data acquisition.

3. Press: 

The data relating to the selected parameters is displayed.



The screenshot shows a software interface with a dark header bar. On the left, there is a blue logo with the text 'TEXA' and a white icon of a car. On the right, it says 'EOBD Protocol' with a red 'X' icon. Below the header, the text 'Evaluating parameters' is visible. A table with three columns is displayed: 'Description', 'ECU', and 'Value'. The table contains one row of data.

Description	ECU	Value
OBD Monitoring Conditions Encountered Counts Calibration Identifications	510	0601M78



The screen provides the following information:

- *Description of the parameter.*
- *Control unit address.*
- *Value of the parameter.*

32 HD STANDARD PROTOCOL / OHW STANDARD PROTOCOL



The **HD Standard Protocol** and **OHW Standard Protocol** functions allow carrying out a diagnosis using specific protocols (each function for the environments it is available in):

Environment	Function	Protocols
	HD Standar Protocol	J1708 J1939
	OHW Standar Protocol	J1939

The methods of use by the operator for the software remain the same.
Proceed as follows:

1. Press: 
2. Select the diagnostic cable.(Only for *OHW Standard Protocol*)

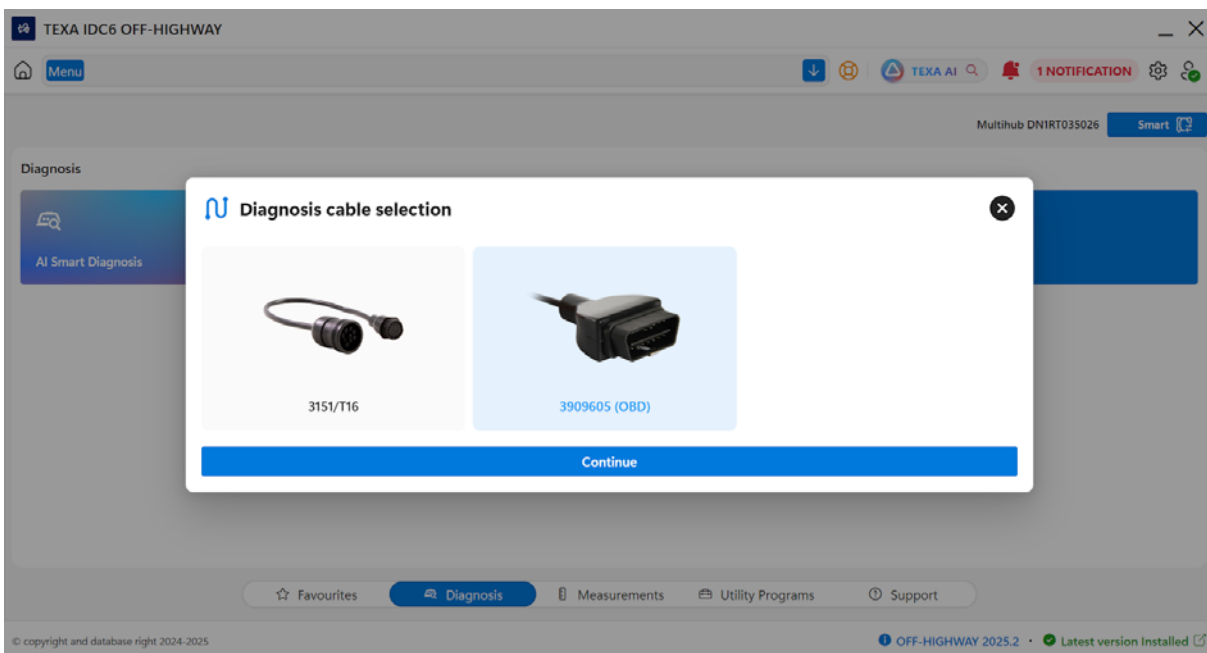

3. Press:**Continue**(Only for *OHW Standard Protocol*)

4. Press:Next

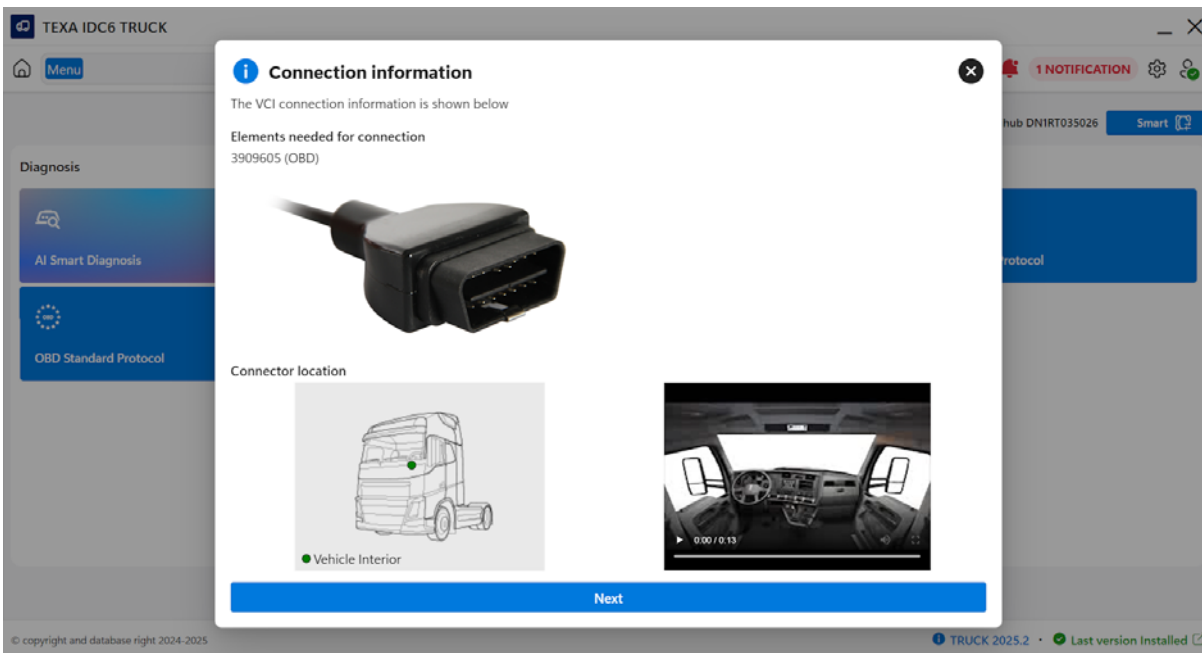

5. Follow the instructions that appear on screen.

6. Press:CONFIRM



Turn on the ignition
Press CONFIRM

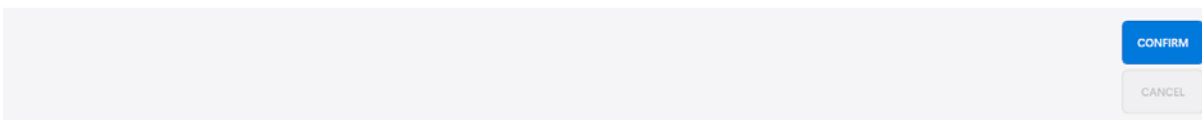

Wait for the scan to be complete.



Wait...
J1708 protocol scan in progress...

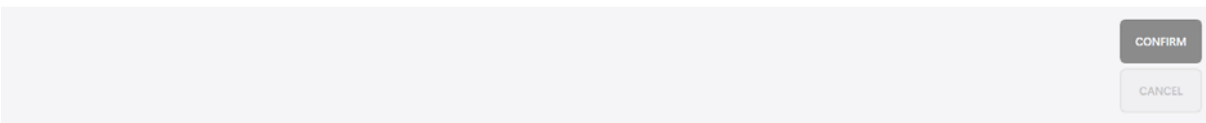



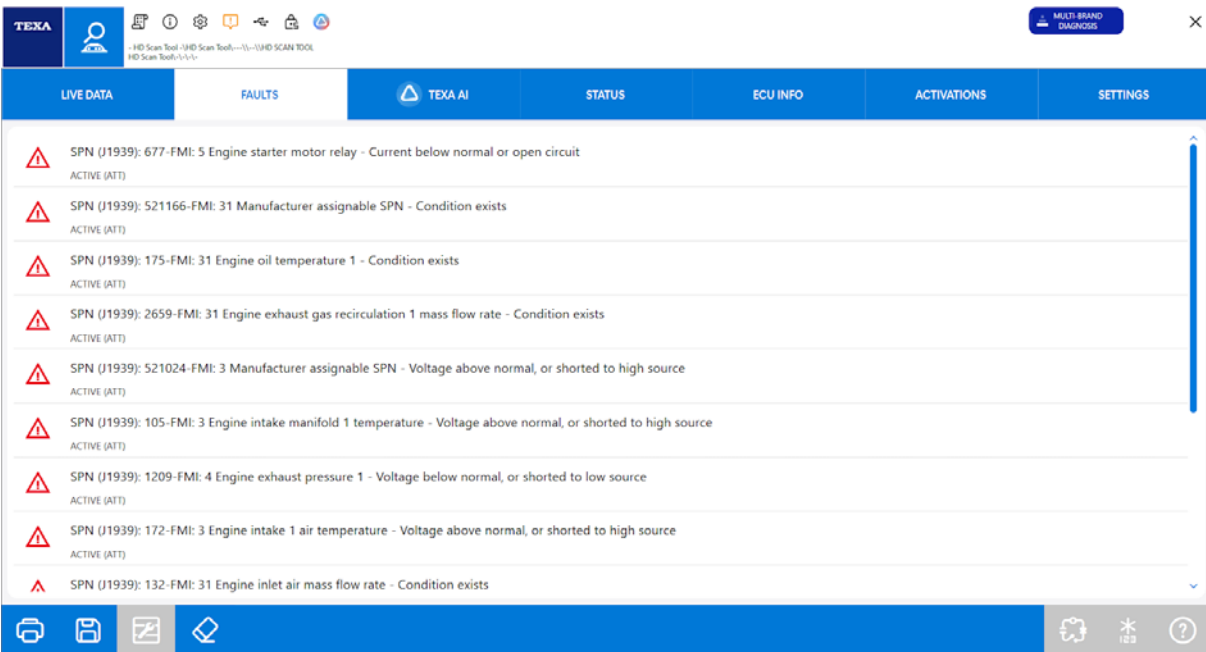

The screen displaying the results of the scan appears.



In the upper part of the screen, the following is available:

Icon	Name	Description
	ToolTips	It allows viewing the legend of the icons used in the current page.
	Information	It allows viewing information regarding the VCI in use.
	Settings	It allows selecting the system of measurement to be used.
	VCI connection	It allows displaying the mode the VCI is connected with. The icon will change based on the connection mode used.

	iSupport	It allows sending support and/or specific diagnostic content development requests.
	Fault notification	It allows sending data and information on operations carried out during the diagnosis but not successful.
	Off-line special code	It allows viewing the number of remaining off-line special settings.
	TEXA AI	It allows launching the search function powered by AI.

In the central part of the screen, the following is available:

Name	Description
Parameters	It allows managing the monitoring of the parameters provided by the control unit.
Errors	It allows displaying and deleting the errors detected by the control unit.
TEXA AI	It allows using the AI SMART DIAGNOSIS functions.
Status	It allows viewing the statuses that the specific data provided by the software acquires.
ECU info	It allows viewing information related to the control unit you are connected to and identifying it correctly.
Activations	It allows testing the operation of specific actuators (components piloted by the control unit) by activating them temporarily.
Adjustments	It allows performing permanent adjustments on specific electronic components.

INFORMATION

Based on the vehicle, some Diagnostic Functions may not be available.

For some vehicles, it is possible to view the parameters and statuses within a single screen.

This type of display makes the diagnosis less dispersive and it also makes it easier to gather information.

In the lower part of the screen, the specific functions for the current page are available.

For further information, see the chapter:DIAGNOSIS BY SYSTEM

33 ISOBUS



This function allows carrying out a diagnosis based on the ISO 11783 protocol dedicated to the accessories/equipment in the OFF-HIGHWAY environment.

Proceed as follows:

1. Press: 
2. Follow the instructions that appear on screen.



Systems Scan X

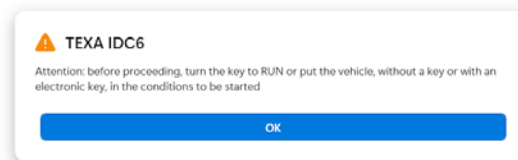

3. Press: **OK**

Wait for the scan to be complete.









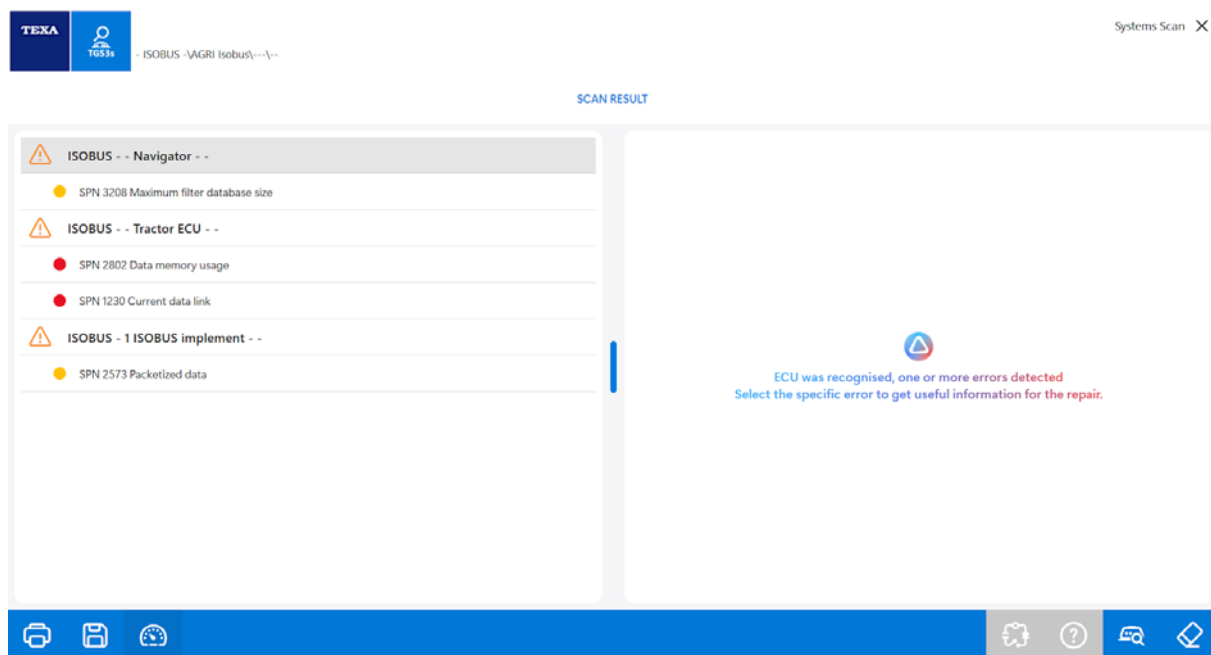

Systems Scan X

Scanning ...



The screen displaying the results of the scan appears.



Icon	Name	Description
	Print	It allows you to print a report related to the detected errors.
	Save	It allows recording the detected errors and saving them in the Customer Management archive.
	Dashboard	It allows viewing a graphical representation of the vehicle that is useful for the diagnostic operations.
	Component location	It allows finding the component affected by the error through the Wiring Diagrams function.
	Help	It allows displaying a help screen related to the selected error.
	Diagnosis	It allows starting the diagnosis on the system related to the selected error.
	Delete Errors	It allows deleting the detected errors.

4. Select an error.

The tabs relating to the AI functions available for the selection performed will be displayed.

For further information, see the chapters:

- *AI SMART DIAGNOSIS*
- *DIAGNOSIS BY SYSTEM*

34 SPECIAL CODE



This function allows viewing the status of the off-line mode for the Special Code service to carry out the Special Settings.

Using this function, you can request the activation of the service for the environments in which it is available.

INFORMATION

Near the function icon you can find the number of remaining adjustment operations available in off-line mode.

Proceed as follows:

1. Press:



The service status is displayed.

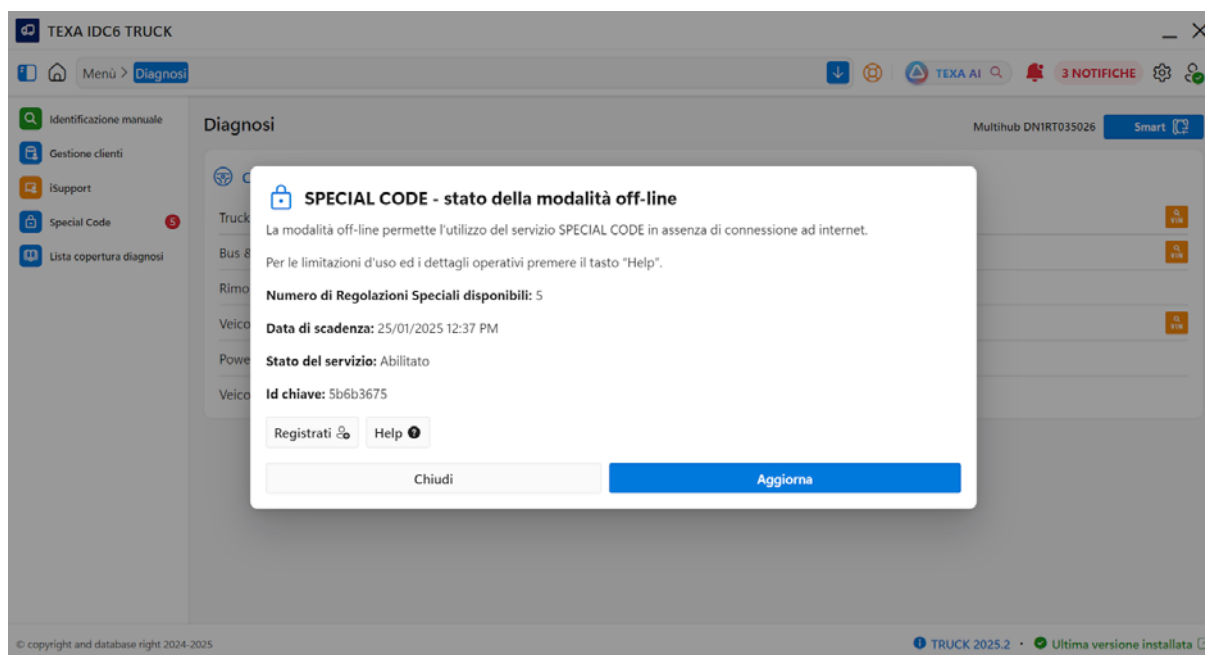

Icon	Name	Description
	Sign up	It allows viewing the form to request the service activation.
	Help	It allows viewing a document with the limitations of use and operating details of the service.

The screen provides the following information:

- *number of special adjustments available;*
- *expiration date;*
- *service status;*
- *key ID.*

INFORMATION

To reset the number of off-line adjustments once they are used up, connect to the Internet and press: **Update**

35 MAINTENANCE SERVICE



This application allows quickly accessing all the functions relating to the vehicle maintenance.

Proceed as follows:

1. Press:

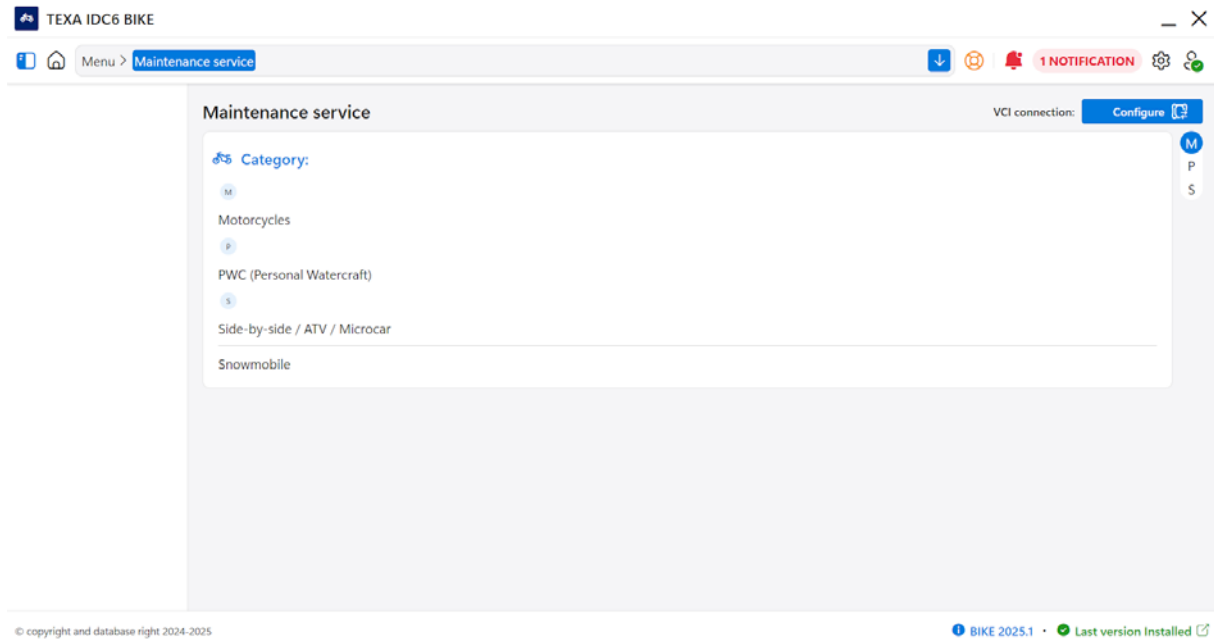

2. Carry out a complete selection.
3. Select the type of system.

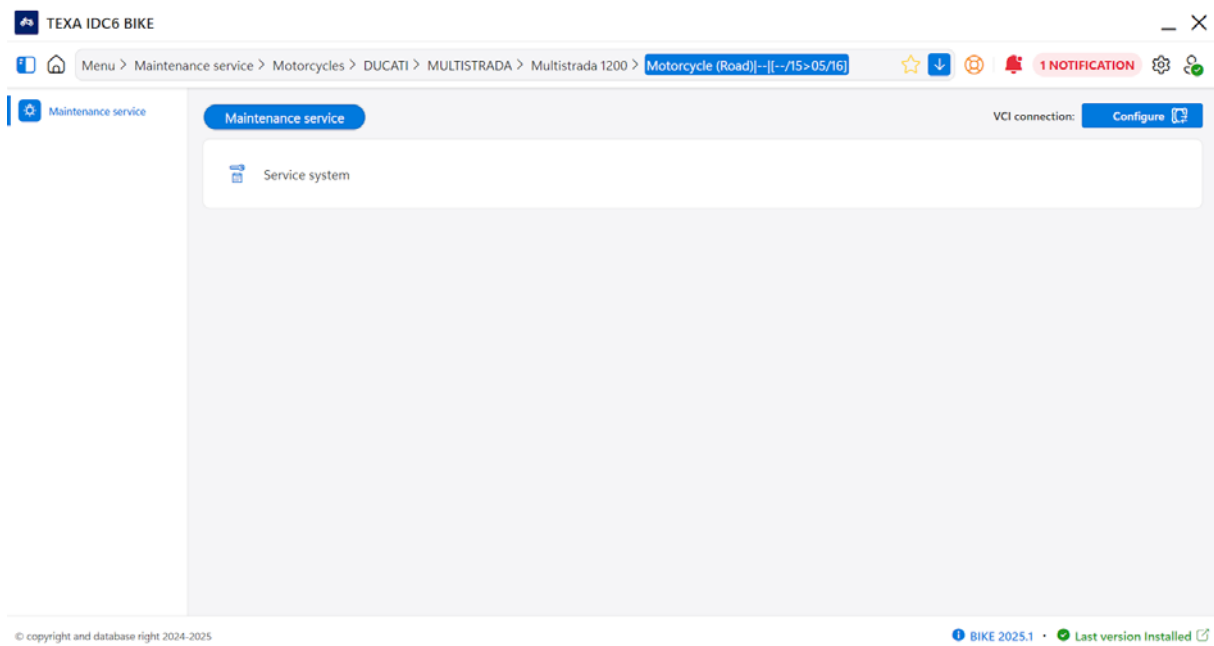

4. Select the desired function.

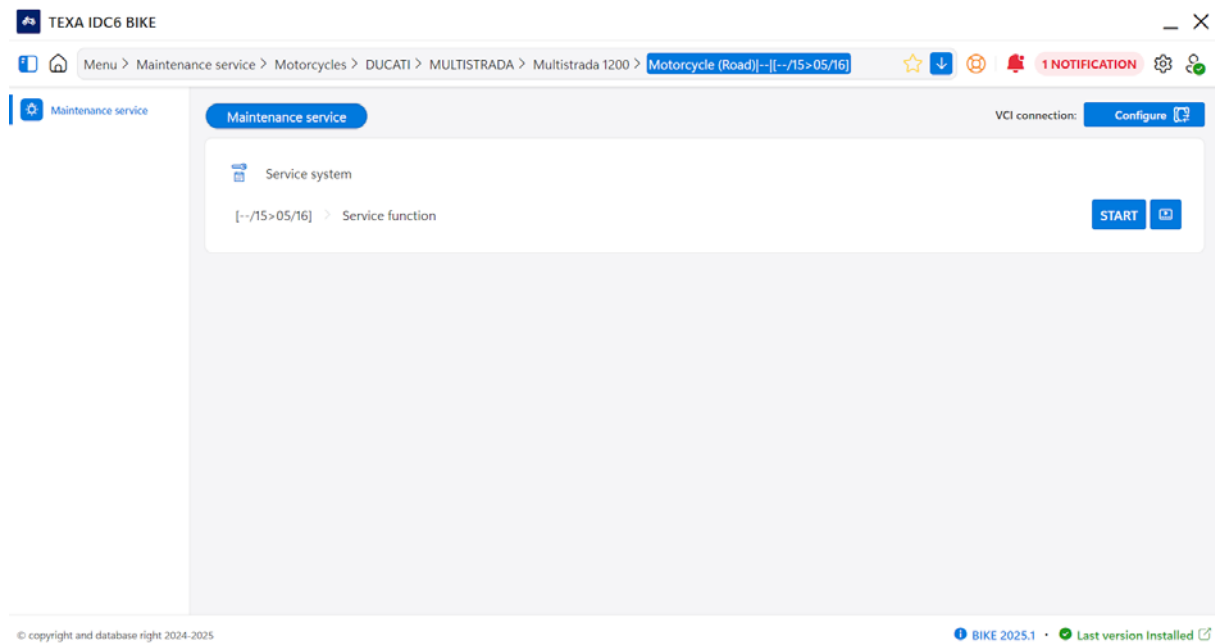

5. Press: **START**

A guided procedure is started.

6. Follow the instructions that appear on screen.

36 TECHNICAL DATA / MAINTENANCE



This function allows obtaining information related to:

- *vehicle maintenance*;
- *technical data*.

NOTICE

The information was obtained from the documentation supplied by the vehicle manufacturer.

We however recommend always referring to the original documentation supplied by the manufacturer.

Proceed as follows:



1. Carry out a complete selection.

2. Press: 

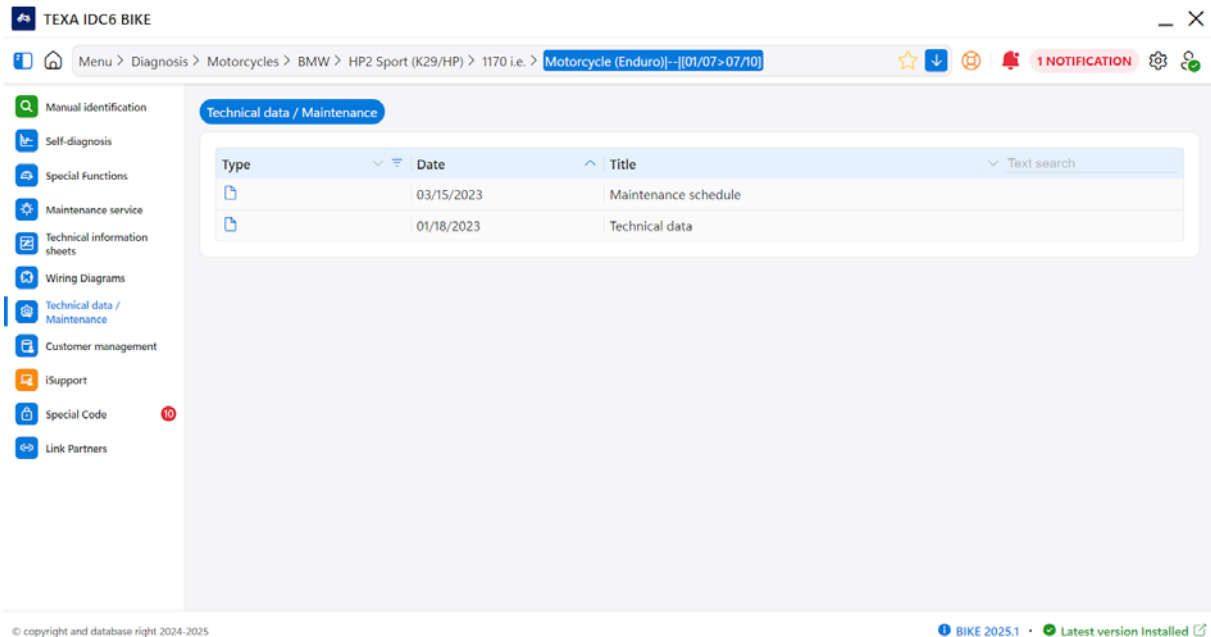
The list of available documents is displayed.



The screenshot shows the TEXA IDC6 BIKE software interface. The breadcrumb navigation path is: Menu > Diagnosis > Motorcycles > BMW > HP2 Sport (K29/HP) > 1170 i.e. > Motorcycle (Enduro)]-[01/07>07/10]. The left sidebar contains various menu items, with 'Technical data / Maintenance' selected. The main content area displays a table with the following data:

Type	Date	Title
	03/15/2023	Maintenance schedule
	01/18/2023	Technical data

3. Press on the desired document to view the content.

36.1 Maintenance Schedule

This document contains the vehicle's maintenance schedule as indicated by the manufacturer of the vehicle/engine.

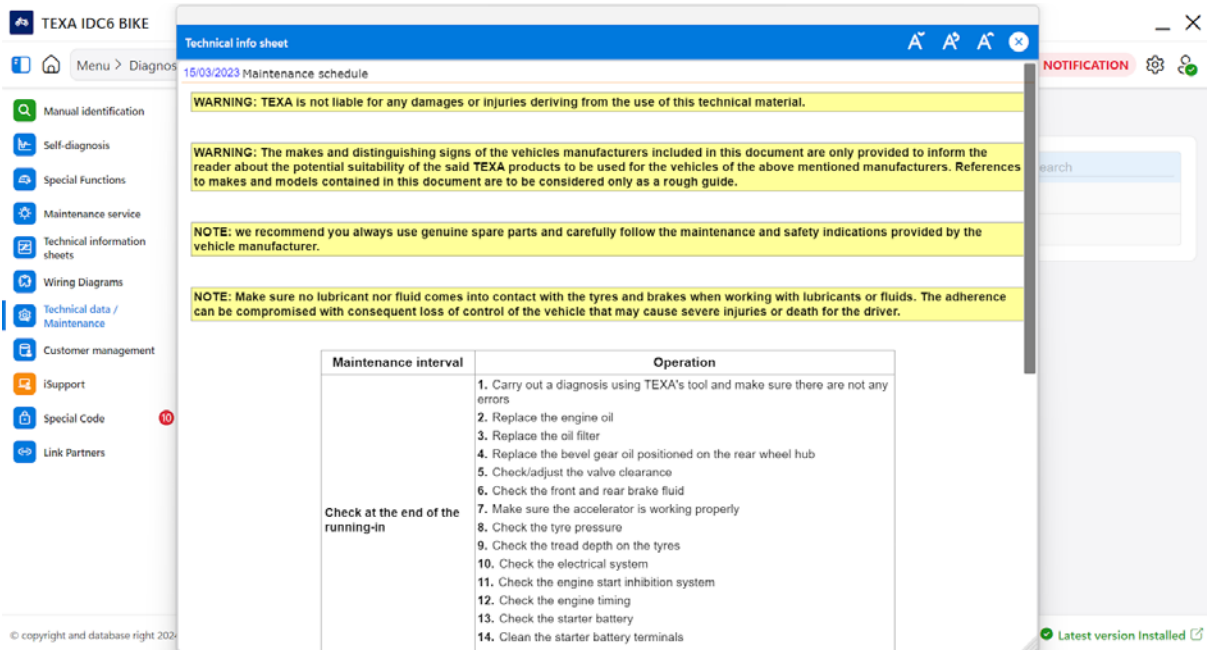

TEXA IDC6 BIKE

Technical info sheet

15/03/2023 Maintenance schedule

WARNING: TEXA is not liable for any damages or injuries deriving from the use of this technical material.

WARNING: The makes and distinguishing signs of the vehicles manufacturers included in this document are only provided to inform the reader about the potential suitability of the said TEXA products to be used for the vehicles of the above mentioned manufacturers. References to makes and models contained in this document are to be considered only as a rough guide.

NOTE: we recommend you always use genuine spare parts and carefully follow the maintenance and safety indications provided by the vehicle manufacturer.

NOTE: Make sure no lubricant nor fluid comes into contact with the tyres and brakes when working with lubricants or fluids. The adherence can be compromised with consequent loss of control of the vehicle that may cause severe injuries or death for the driver.

Maintenance interval	Operation
Check at the end of the running-in	<ol style="list-style-type: none"> 1. Carry out a diagnosis using TEXA's tool and make sure there are not any errors 2. Replace the engine oil 3. Replace the oil filter 4. Replace the bevel gear oil positioned on the rear wheel hub 5. Check/adjust the valve clearance 6. Check the front and rear brake fluid 7. Make sure the accelerator is working properly 8. Check the tyre pressure 9. Check the tread depth on the tyres 10. Check the electrical system 11. Check the engine start inhibition system 12. Check the engine timing 13. Check the starter battery 14. Clean the starter battery terminals

© copyright and database right 2023

Latest version Installed

36.2 Technical Data

This document contains the vehicle's technical data as indicated by the manufacturer of the vehicle/engine.

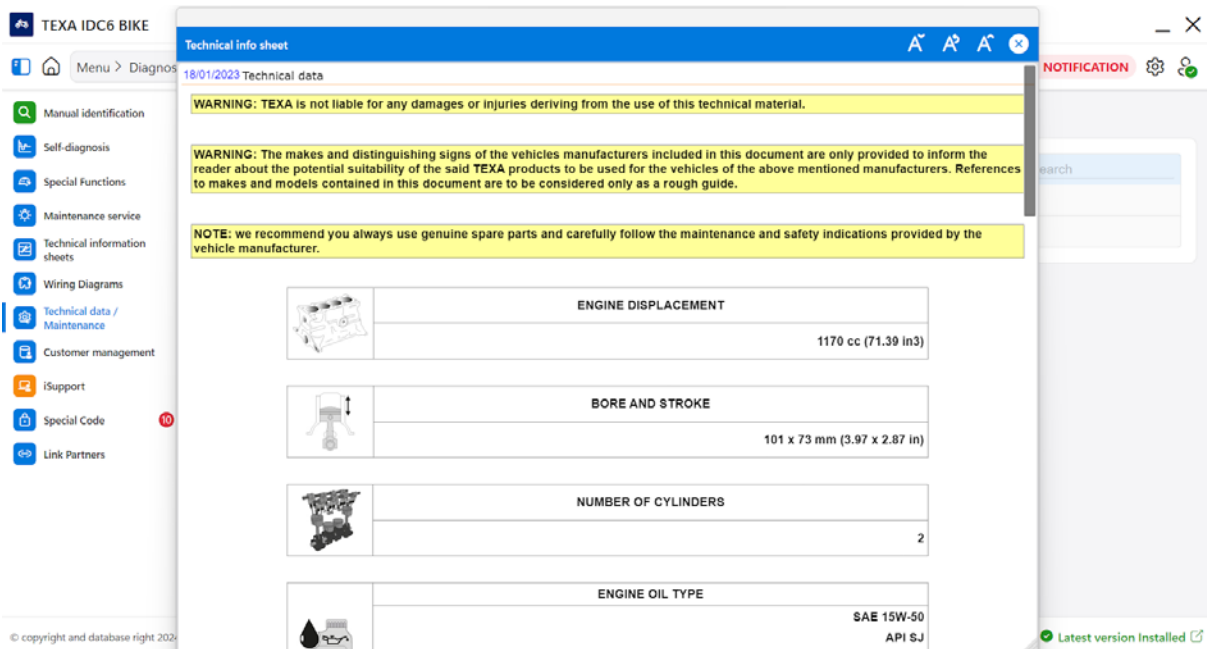

TEXA IDC6 BIKE





Technical info sheet

18/01/2023 Technical data

WARNING: TEXA is not liable for any damages or injuries deriving from the use of this technical material.

WARNING: The makes and distinguishing signs of the vehicles manufacturers included in this document are only provided to inform the reader about the potential suitability of the said TEXA products to be used for the vehicles of the above mentioned manufacturers. References to makes and models contained in this document are to be considered only as a rough guide.

NOTE: we recommend you always use genuine spare parts and carefully follow the maintenance and safety indications provided by the vehicle manufacturer.

	ENGINE DISPLACEMENT	1170 cc (71.39 in3)
	BORE AND STROKE	101 x 73 mm (3.97 x 2.87 in)
	NUMBER OF CYLINDERS	2
	ENGINE OIL TYPE	SAE 15W-50 API SJ

© copyright and database right 2023

Latest version Installed

37 TEXA TENSION CONTROL



This function allows displaying the documentation on how to use the **TEXA TTC** device and on the tensioning values of the timing belts.

Proceed as follows:

1. Carry out a complete selection.

2. Press:

The list of available documents is displayed.

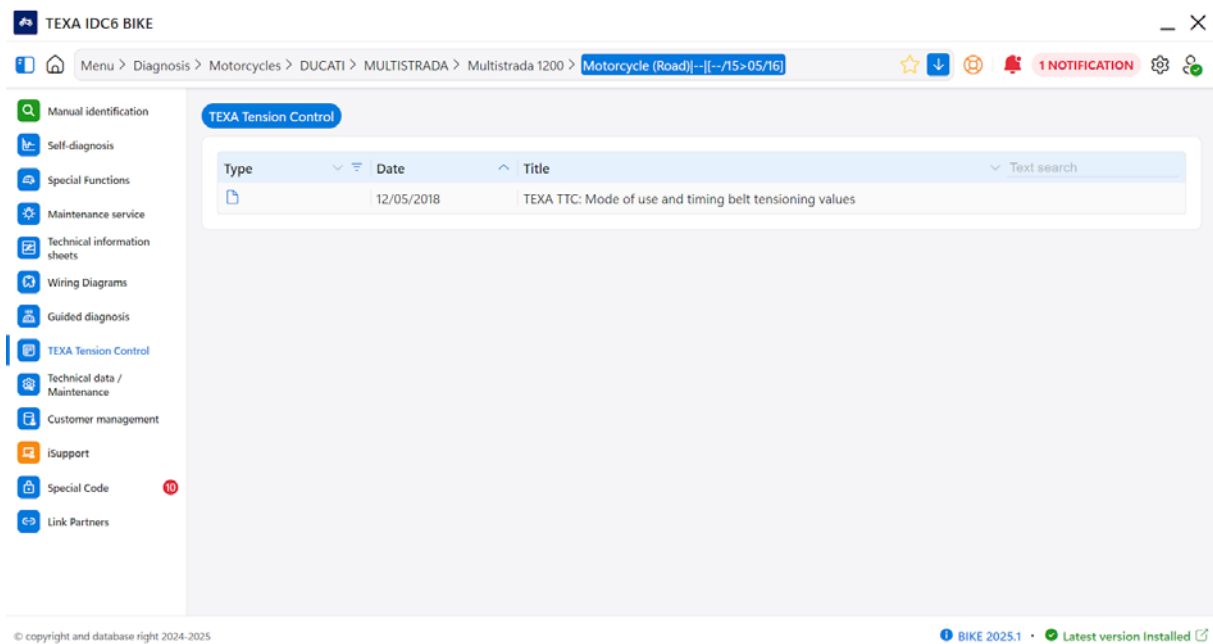

3. Press on the desired document to view the content.

The document is displayed.

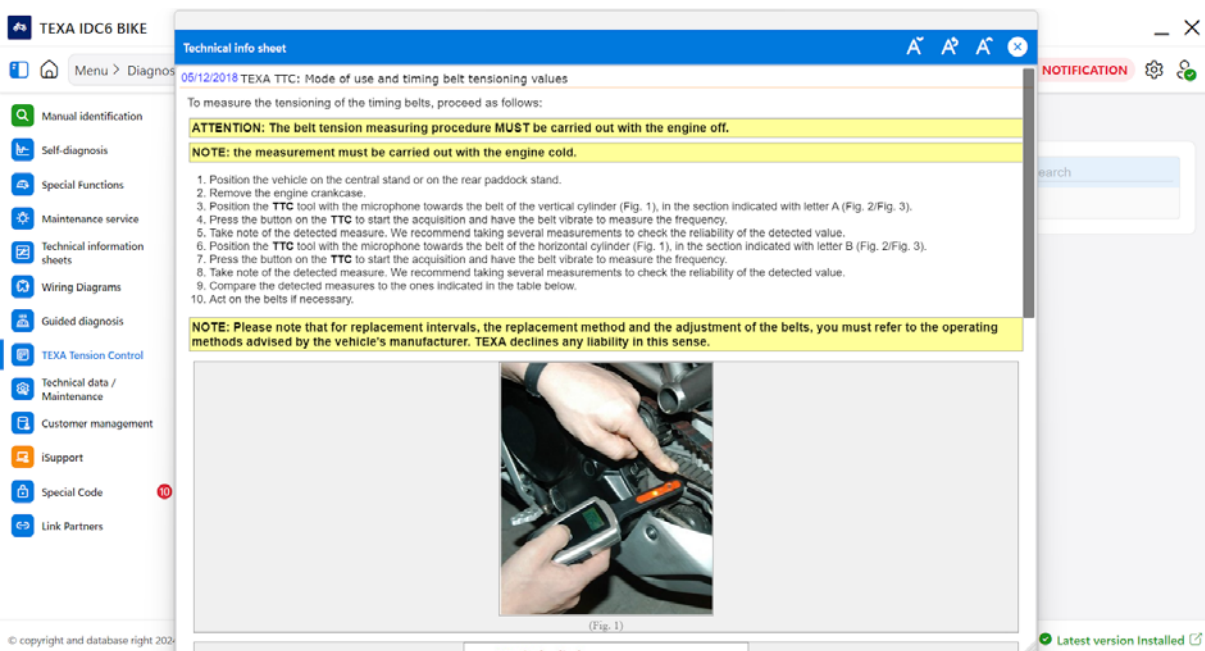

38 SPECIAL FUNCTIONS (BIKE DIAGNOSIS)



This function allows accessing a subset of functions that are particularly relevant and used frequently.

Proceed as follows:

1. Carry out a complete selection.

2. Press: 

The list of the available special functions is displayed.

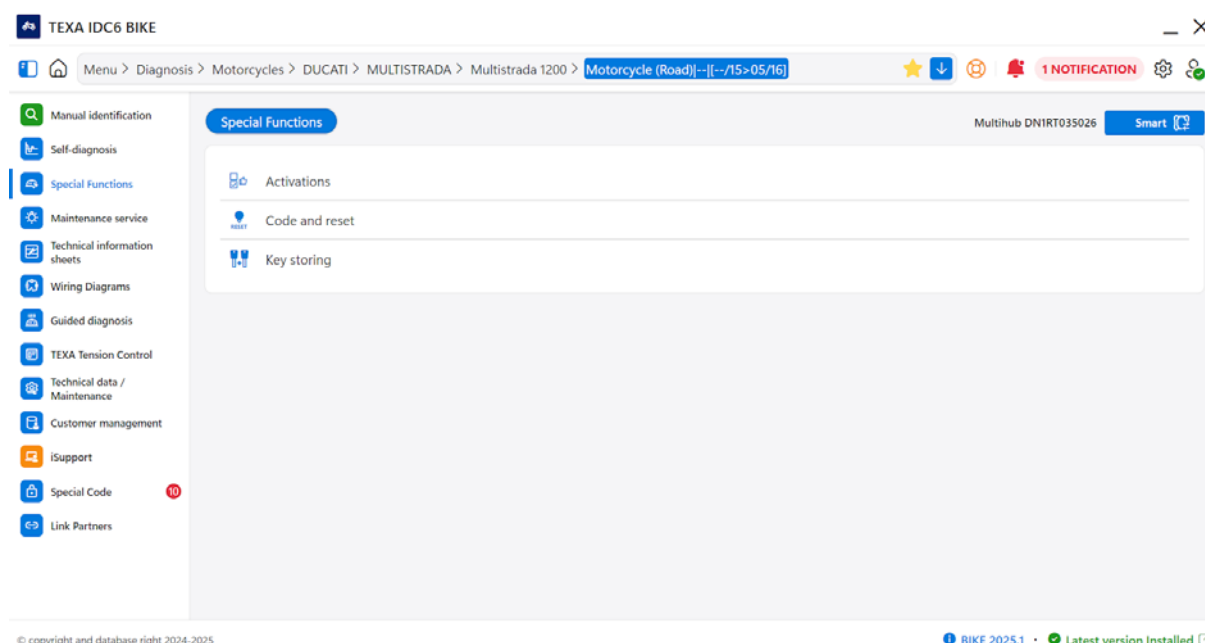

INFORMATION

The number and the type of functions depend on the selection made.

3. Press on the desired function.

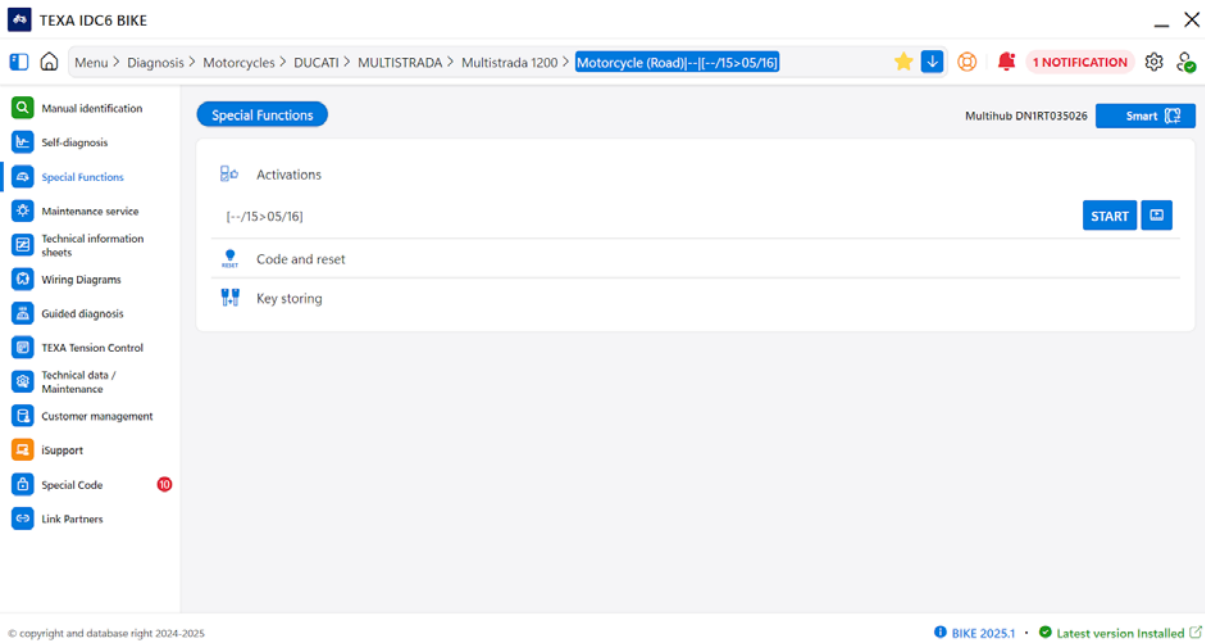

4. Press on the desired variant.

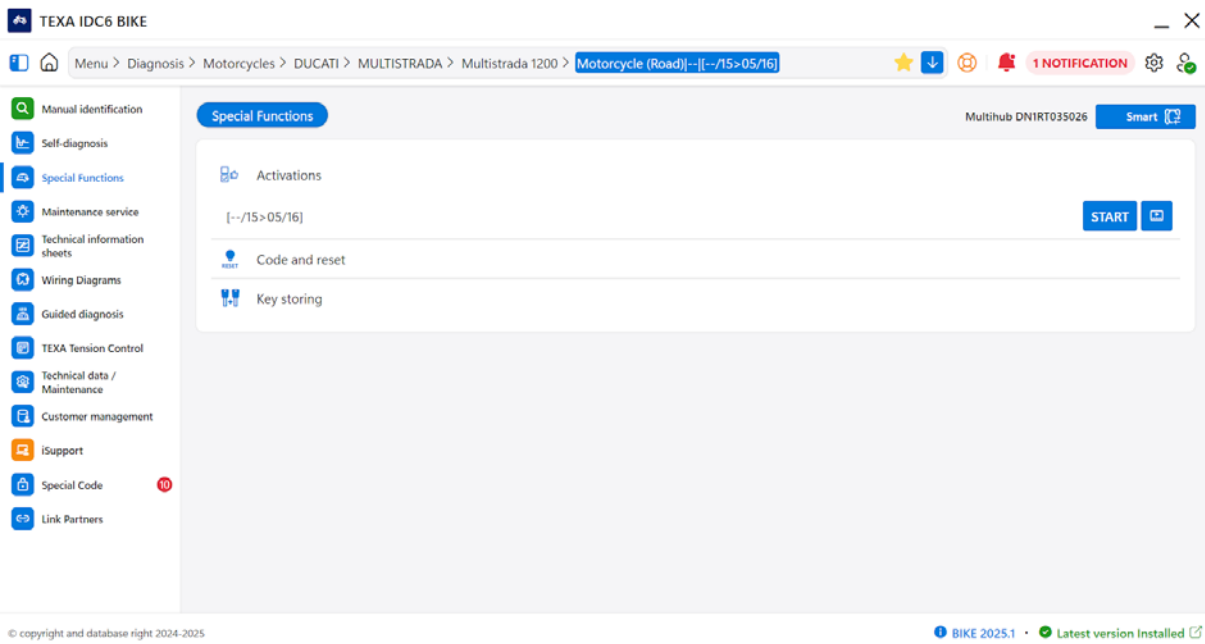

5. Follow the instructions that appear on screen.

6. Press:CONFIRM



Self-diagnosis X

Turn on the instrument panel
Press CONFIRM

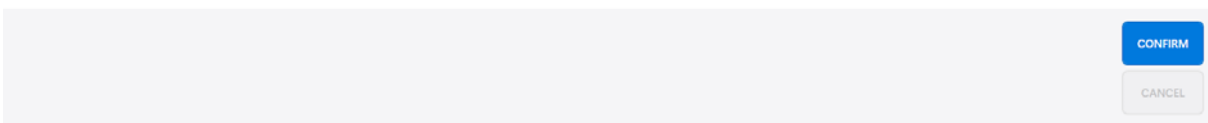

The diagnosis screen appears.

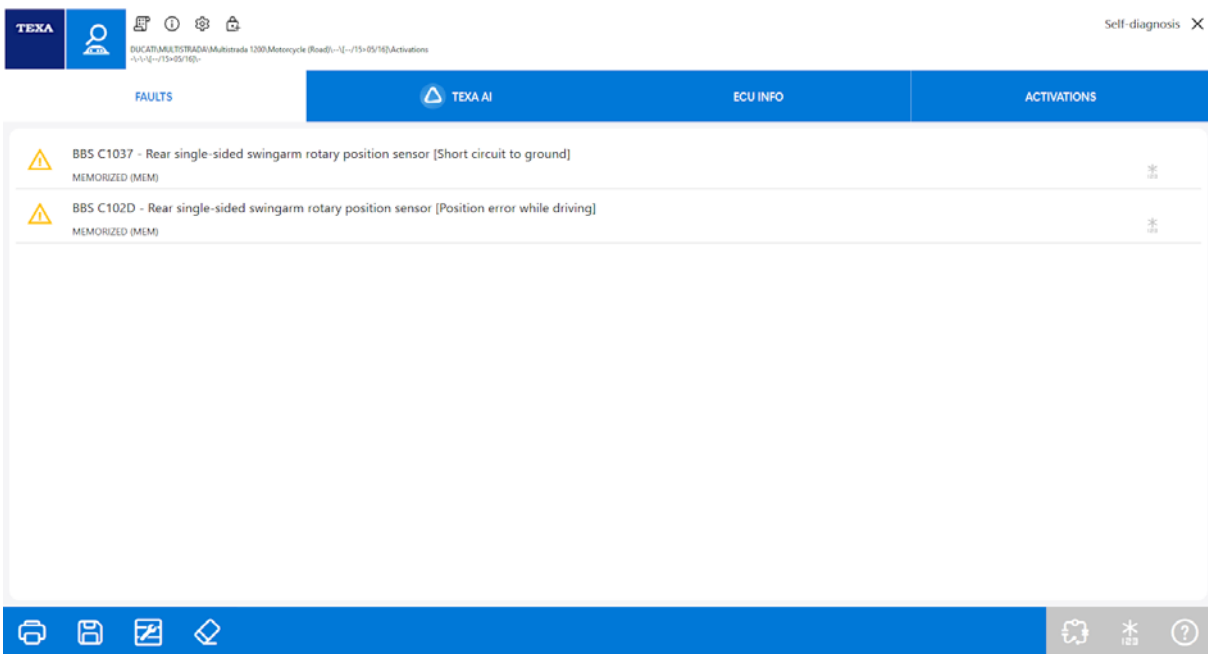

INFORMATION

The number and the type of functions depend on the selection made.

For further information, see the chapter:DIAGNOSIS BY SYSTEM

39 GLOBAL SCAN



This function allows you to access information related to the systems in the vehicle.

To launch the function, you must select at least the **Category**, **Make**, **Model** and **Engine type**.

The scan procedure is able to:

- *Verify the presence of the selected systems.*
- *Check if the system unit has been identified univocally or not *.*
- *Check if the system that responded has any errors.*

(*) The **incorrect detection** indicates that the specific system responded unexpectedly to the selection carried out on the systems list.

In these cases, the communication between the diagnostic device and the system is possible, but the quality of the diagnosis is not guaranteed and all the coding and / or programming functions are disabled.

Proceed as follows:

1. Carry out a complete selection.

2. Press:

3. Follow the instructions that appear on screen.

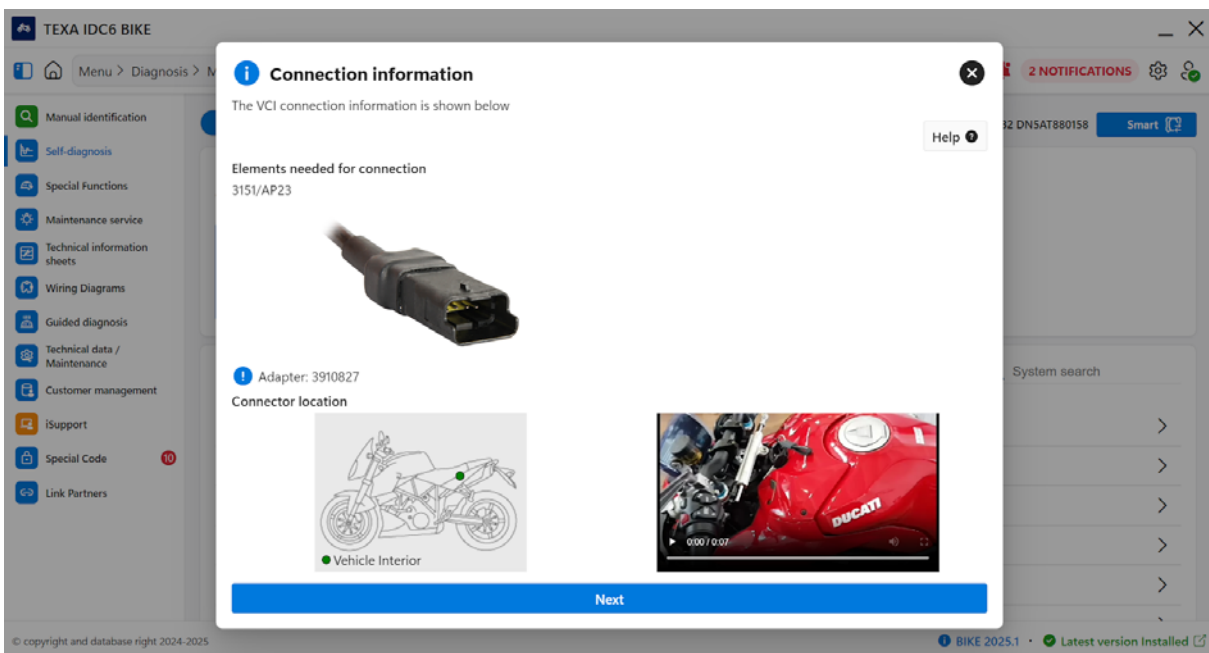

4. Press: **Next**

Wait for the scan to be complete.



Global Scan X

Scanning . . .
Please wait...

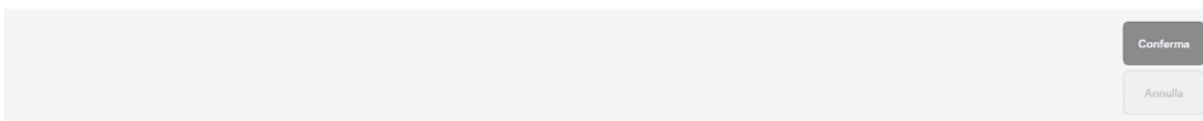

The screen displaying the results of the scan appears.



Global Scan X

SCANSIONE VELOCE DTC RILEVATI

A	System	B	C	D	VIN	Odometer	E	F	G	H
⚠	Injection control unit CONTINENTAL [--/18>]	A	A	D2630311ABAAN1	ZDMDA02AAJB999920					
⚠	BBS control unit EGICON [--/18>]			28	ZDMDA02AAJB999920	26589 [km]	S			
⚠	Instrumentation control unit MAE [--/18>]	A	A	Boot: 02 - SW: 51 - Flash: 50 - PTA: 53	ZDMDA02AAJB999920	26589 [km]				13/02/24
⚠	ABS control unit Bosch [--/18>]	N	N	96726_20	ZDMDA02AAJB999920		S	IMU sensor test to be carried out		
⚠	Suspension ECU Ohlins [--/18>]	B	B	16	ZDMDA02AAJB999920					
✕	Bluetooth control unit CoBo [--/18>]	-	-	0						

LEGEND:

A = System present/absent, with/without errors	B = Software compatibility
C = Software compatibility expected	D = Software version
E = BBS configuration	F = ABS configuration
G = ABS EOL mode	H = Last service date Annual Service

The following pages are available:

QUICK SCAN	It shows the result of the quick scan on the systems detected in the vehicle.
DTC DETECTED	It shows the list of the errors detected.

39.1 Quick Scan

The result of the quick scan on the systems detected in the vehicle is available on this page. You can select an error and start the diagnosis on the system it refers to.

Proceed as follows:

1. Press: **QUICK SCAN**

The list of detected systems is displayed.

The screenshot shows a diagnostic software interface with a header 'SCANSIONE VELOCE' and 'DTC RILEVATI'. Below the header is a table listing detected systems with columns for System, B, C, D, VIN, Odometer, E, F, G, and H. The table contains several rows of data, including 'Injection control unit CONTINENTAL', 'BBS control unit EGICON', 'Instrumentation control unit MAE', 'ABS control unit Bosch', 'Suspension ECU Ohlins', and 'Bluetooth control unit CoBo'. A legend at the bottom explains the icons and codes used in the table.

A	System	B	C	D	VIN	Odometer	E	F	G	H
	Injection control unit CONTINENTAL [--/18>]	A	A	D263031IABAAN1	ZDMDA02AAJ8999920					
	BBS control unit EGICON [--/18>]			28	ZDMDA02AAJ8999920	26589 (km)	S			
	Instrumentation control unit MAE [--/18>]	A	A	Boot: 02 - SW: 51 - Flash: 50 - PTA: 53	ZDMDA02AAJ8999920	26589 (km)				13/02/24
	ABS control unit Bosch [--/18>]	N	N	96726_20	ZDMDA02AAJ8999920		S		IMU sensor test to be carried out	
	Suspension ECU Ohlins [--/18>]	B	B	16	ZDMDA02AAJ8999920					
	Bluetooth control unit CoBo [--/18>]	-	-	0						

LEGEND:
A = System present/absent, with/without errors
B = Software compatibility
C = Software compatibility expected
D = Software version
E = BBS configuration
F = ABS configuration
G = ABS EOL mode
H = Last service date Annual Service

The icon next to each system indicates:

Icon	Description
	The system was detected and there are not any errors.
	The system was not detected. It is possible that the model you are working on does not have the system at issue or that the system is not responding correctly to the request.
	The system was detected and there is at least one error.
	The system was not detected univocally.

Icon	Name	Description
	Print	It allows you to print a report related to the detected errors.
	Diagnosis	It allows starting the diagnosis on the system related to the selected error.

2. Select the desired system.

3. Press: 

4. Press: **OK**



Self-diagnosis X

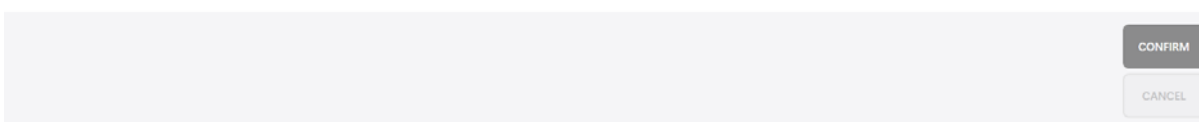
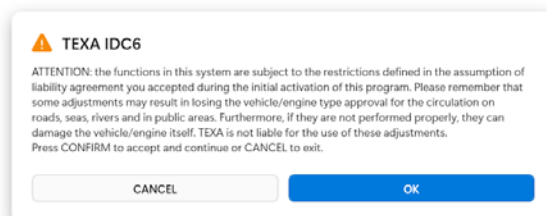

The diagnosis on the selected system is started.

TEXA logo and user profile icon

Self-diagnosis X

PARAMETERS FAULTS **TEXA AI** STATUS ECU INFO ACTIVATIONS SETTINGS

	BBS U0245 - CAN communication error with the Bluetooth control unit [Bluetooth_Data_03 message timeout]	ACTIVE (ATT)	
	BBS U0155 - CAN communication error with the dashboard control unit [DSB_Data_01 message timeout]	MEMORIZED (MEM)	
	BBS U1157 - CAN communication error with the dashboard control unit [DSB_Data_03 message timeout]	MEMORIZED (MEM)	
	BBS U1156 - CAN communication error with the dashboard control unit [DSB_Data_02 message timeout]	MEMORIZED (MEM)	
	BBS U1160 - CAN communication error with the dashboard control unit [DSB_Data_06 message timeout]	MEMORIZED (MEM)	
	BBS U1158 - CAN communication error with the dashboard control unit [DSB_Data_04 message timeout]	MEMORIZED (MEM)	
	BBS P0079 - Exhaust valve potentiometer [Short circuit to ground or Open circuit]	ACTIVE (ATT)	
	BBS P0460 - Fuel level sensor [Short circuit to positive or Open circuit]	ACTIVE (ATT)	
	BBS U100C - DAVC strategies [IMU sensor error]		

Navigation icons: Home, Back, Forward, Refresh, Search, Help

For further information, see the chapter: **DIAGNOSIS BY SYSTEM**

39.2 DTC Detected

This page shows the list of the errors detected.

All the errors detected can be cleared.



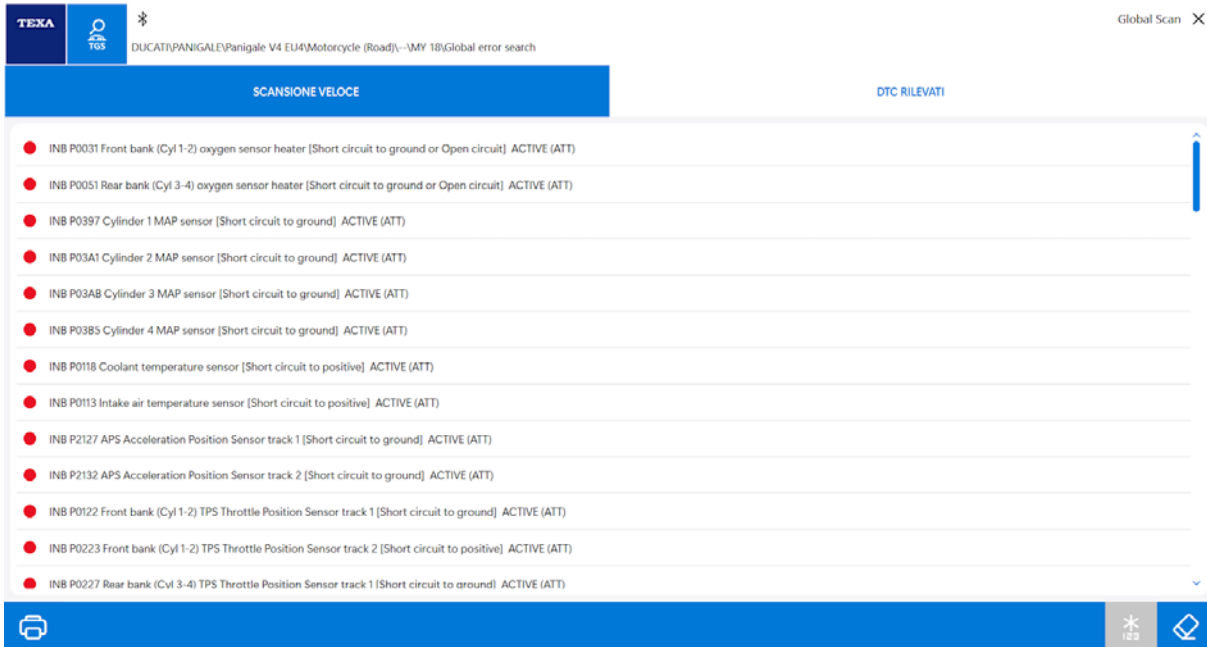

Proceed as follows:

1. Press: **DTC DETECTED**

Wait for the scan to be complete.





The screen uses color LEDs to provide some information:

Colour	Description
	Green The system was detected and there are not any errors.
	Red The system has been detected and there is at least one active error.
	Yellow The system has been detected and there is at least one stored error and no active error.
	Grey The system was not detected. It is possible that the model you are working on does not have the system at issue or that the system is not responding correctly to the request.

INFORMATION

If the system concerned has both active errors and stored errors, the related LED will be red.

Icon	Name	Description
	Print	It allows you to print a report related to the detected errors.
	Delete Errors	It allows deleting the errors detected on all the systems available .



Freeze Frame	It allows viewing the freeze frames provided by the control unit.
--------------	---

For further information, see the chapter:DIAGNOSIS BY SYSTEM

40 ECU UPDATE



This function allows updating the firmware in the vehicle control units.

INFORMATION

Use of this function may be limited or inhibited by the vehicle manufacturer and reserved for specific authorised personnel.

1. Carry out a complete selection.

2. Press:



The list of the reprogrammable control units is displayed.

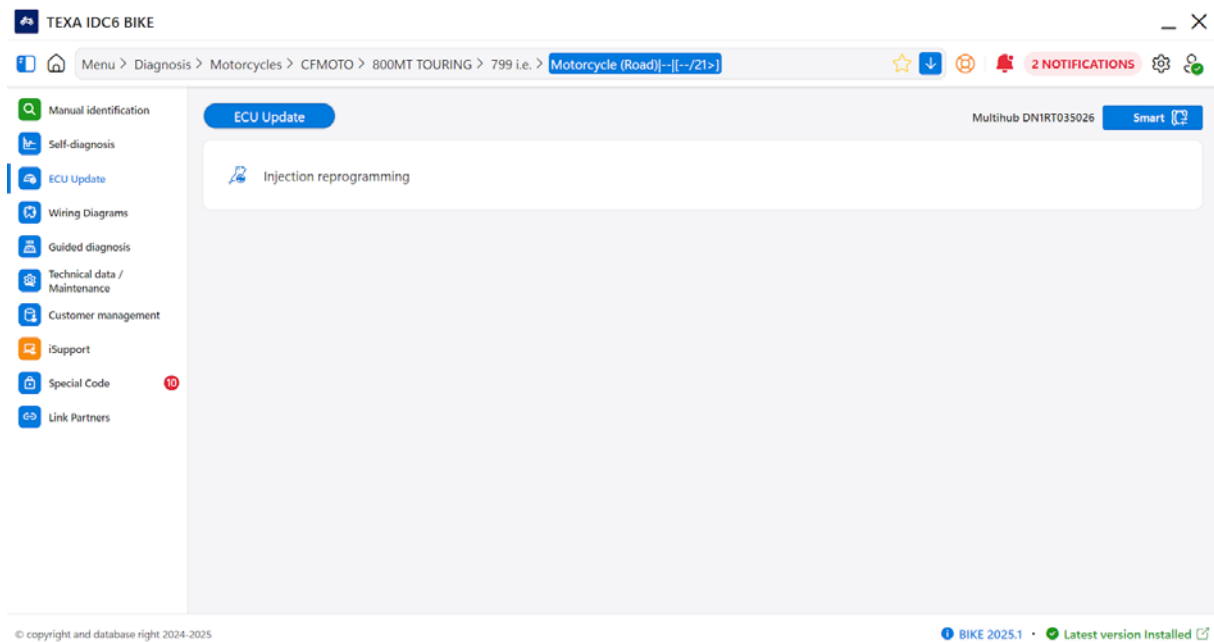

INFORMATION

The number and the type of control units depend on the selection made.

3. Press on the desired control unit.

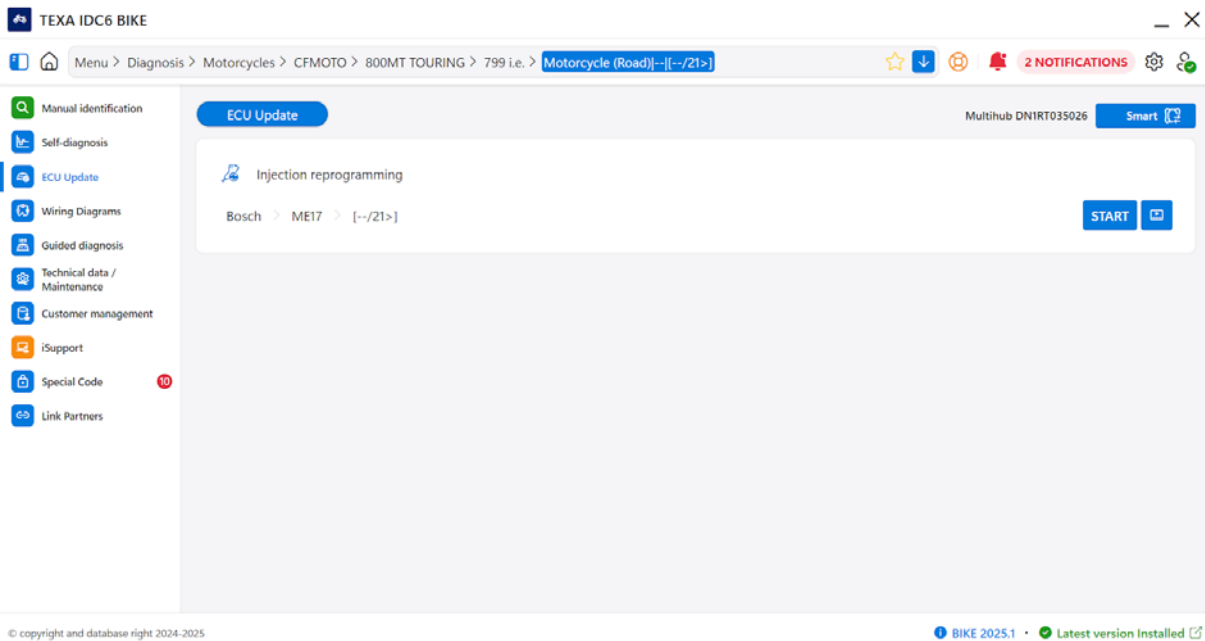

4. Press on the desired variant.

5. If required, select the type of diagnostic cable used.

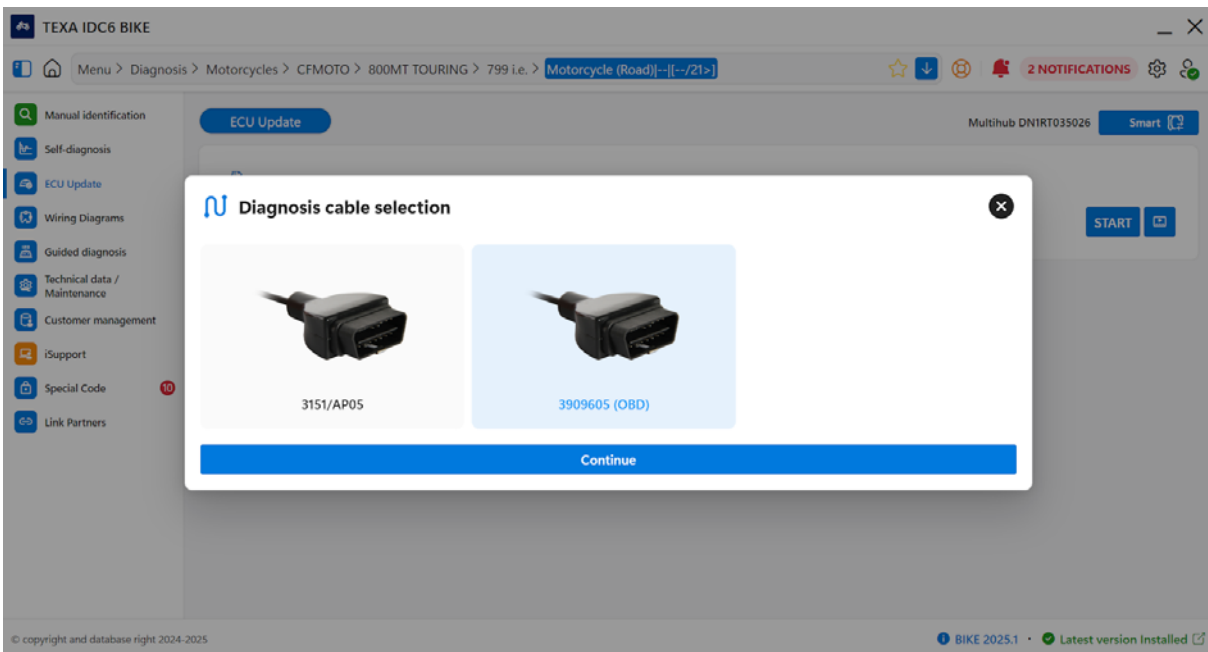

6. Press: **Continue**

7. Follow the instructions that appear on screen.

8. Press:CONFIRM



Self-diagnosis ✕

Turn on the ignition
Press CONFIRM

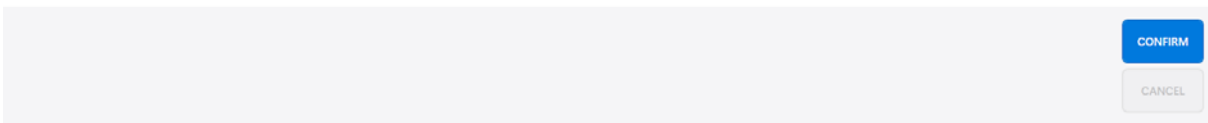

INFORMATION

The procedure may vary based on the control unit selected.

For further information, see the chapter:DIAGNOSIS BY SYSTEM



41 SPECIAL FUNCTIONS SECTION

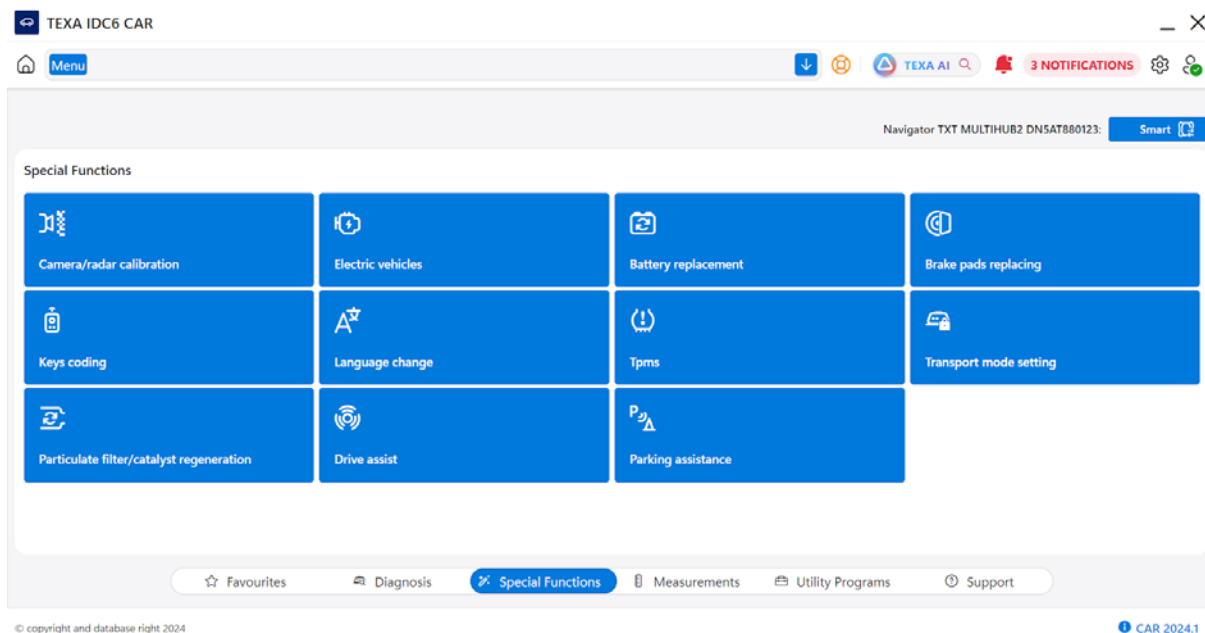

This section gathers the special functions.



Icon	Name	Description
	Camera / radar calibration	It allows accessing the camera and radar calibration functions.
	Electric vehicles	It allows starting the diagnosis on specific systems for electric vehicles.
	Battery replacement	It allows accessing the functions that let you reset the monitoring system after replacing the battery and have the control unit acknowledge the new battery.
	Brake pad replacement	It allows accessing the functions that are useful when replacing the brake pads (ex.: pad thickness recalibration).
	Key coding	It allows coding the keys, remote controls and immobiliser control units in case of malfunctions or need to replace them.
	Language change	It allows changing the setting of the language of the instrument panel, multifunction display or radio.
	TPMS	It allows launching the TPMS sensor maintenance function.
	Transportation mode programming	It allows quickly activating all the vehicle's functions by changing the status "Factory mode" to "Customer Mode".
	Particulate filter/catalyst regeneration	It allows accessing the particulate filter and catalyst regeneration functions.

	Driver assistance	It allows accessing the adaptation and programming functions related to the control units dedicated to the driver's comfort and safety.
	Park assist	It allows accessing the parking sensor programming functions.

INFORMATION

Some functions may not be available for all the environments or on all the platforms.

42 CAMERA / RADAR CALIBRATION

This function allows accessing the camera and radar calibration functions.

The calibration is performed using specific calibration units and devices.

INFORMATION

Before launching the procedure indicated below, any Bluetooth devices that equip the calibration unit must have been configured.

Proceed as follows:

1. Press:

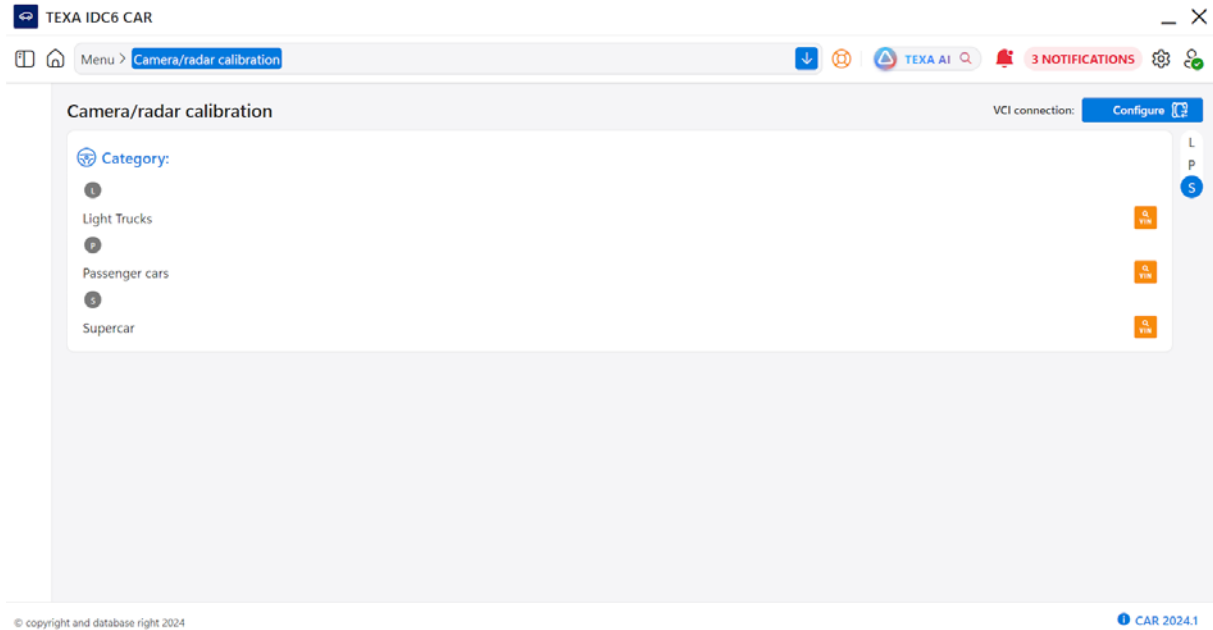

2. Carry out a complete selection.

3. Select the type of system.

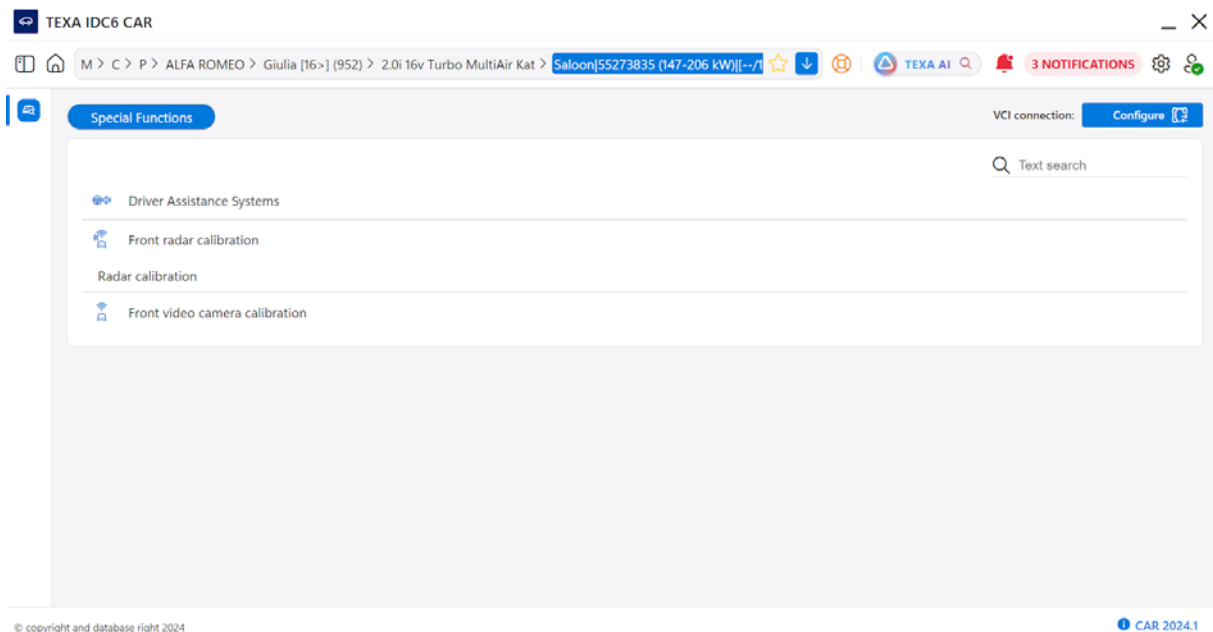

4. Select the calibration:

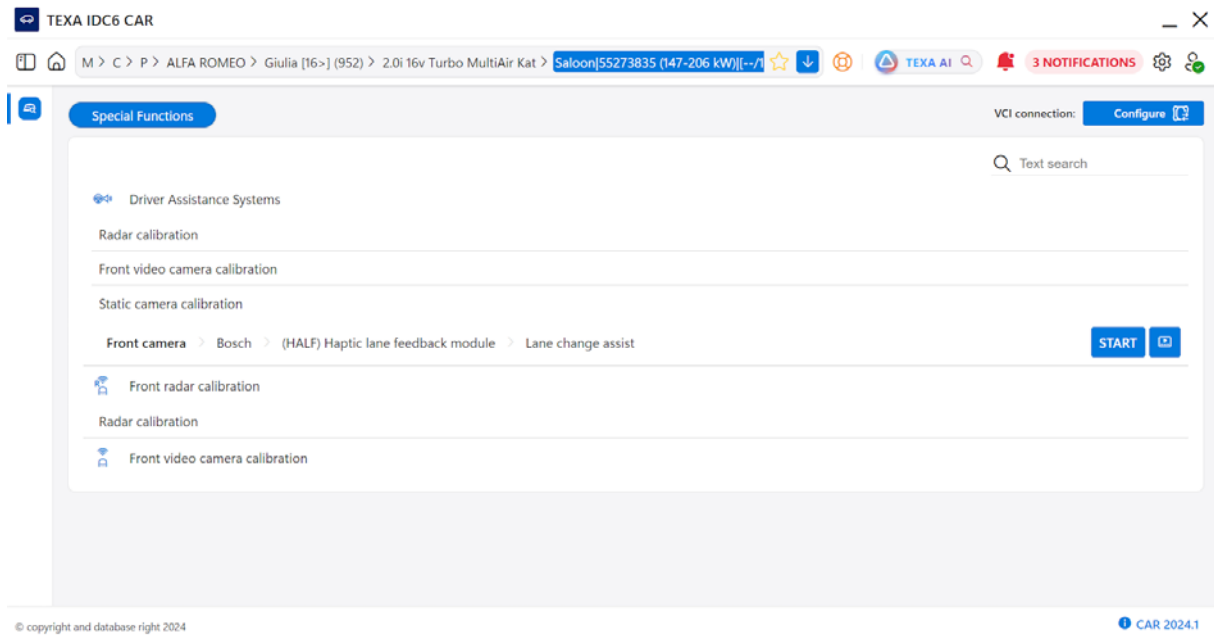

5. Press: **START**

6. Press: **CONFIRM**

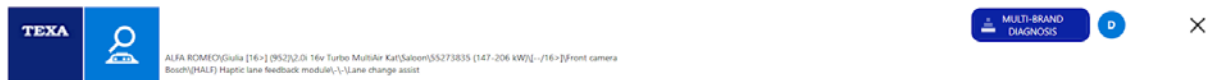

Turn on the instrument panel
Press CONFIRM

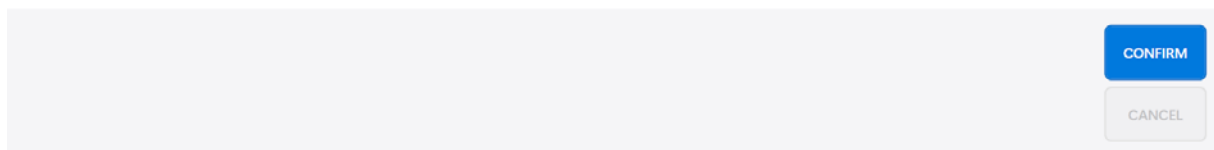

7. Select the calibration KIT that will be used to perform the adjustment.

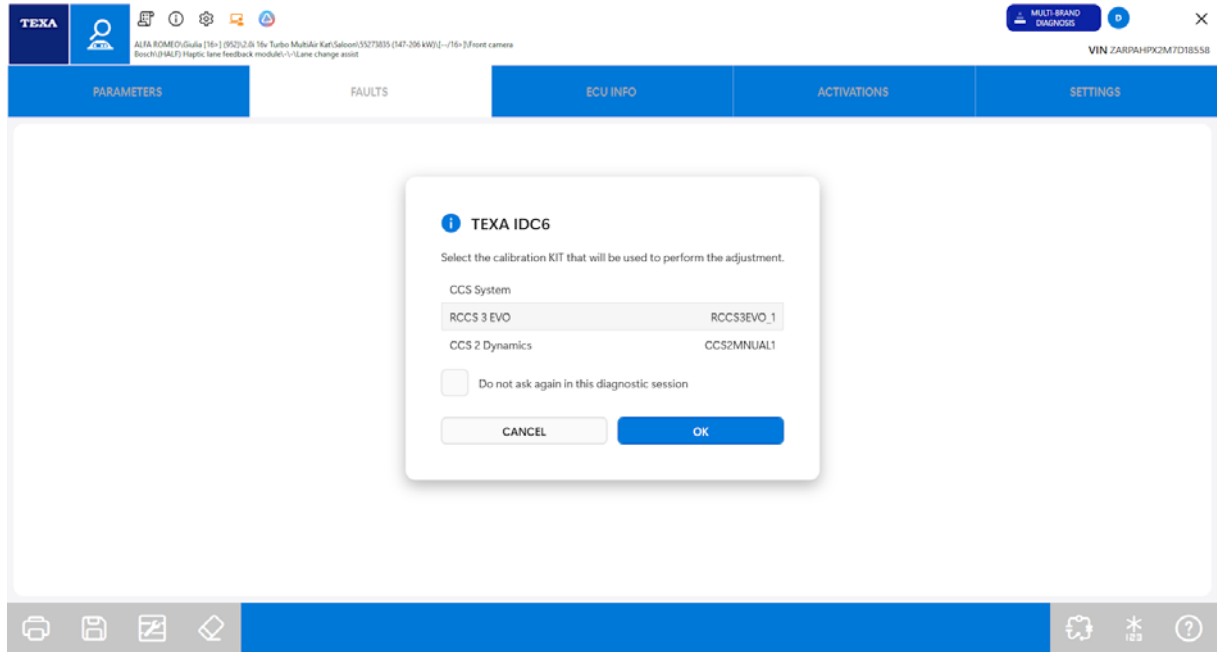

7. Press:OK

INFORMATION



The suggested procedure may vary based on the selected calibration unit.

In some cases, technical sheets that help positioning the calibration unit may be displayed.

Selecting certain calibration units will automatically start an additional function that allows positioning them correctly and connecting them to any Bluetooth peripheral devices.

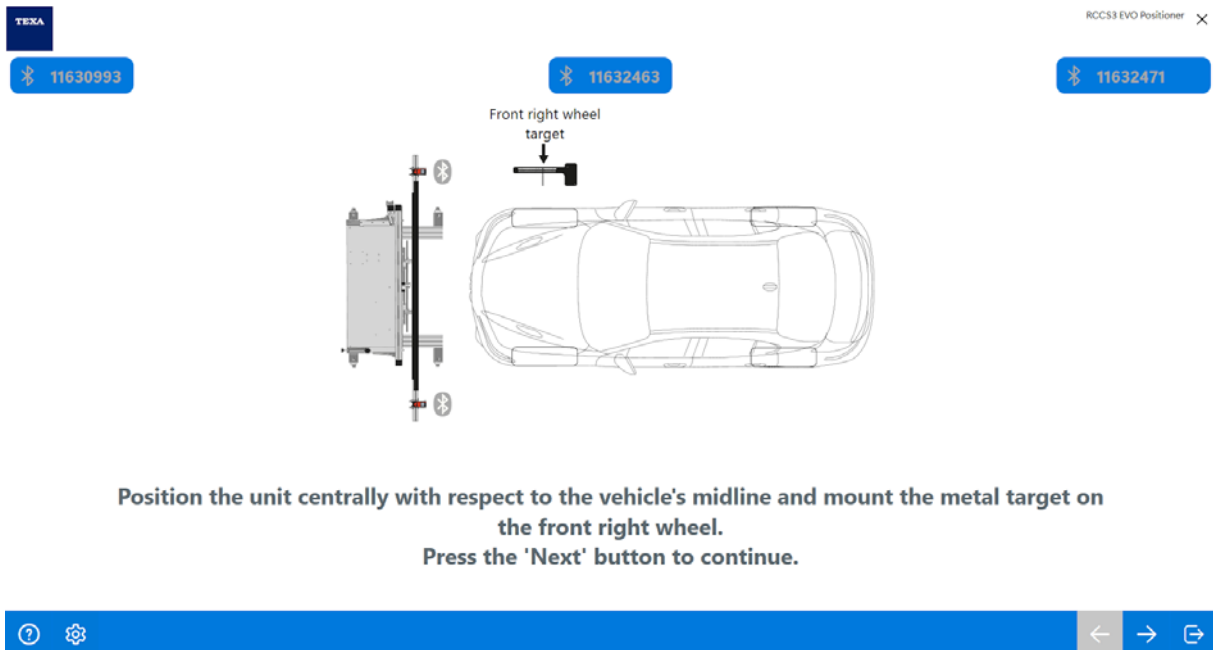
The adjustment procedure is started.



Icon	Name	Description
	Information	It allows displaying a help screen related to the selected setting.
	Device settings	It allows accessing the settings page for the Bluetooth devices that equip the calibration unit.

8. Follow the instructions that appear on screen.

42.1 Device Settings

This function allows accessing the settings page for the Bluetooth devices that equip the calibration unit.

Proceed as follows:

1. Press: 

The available devices are displayed.

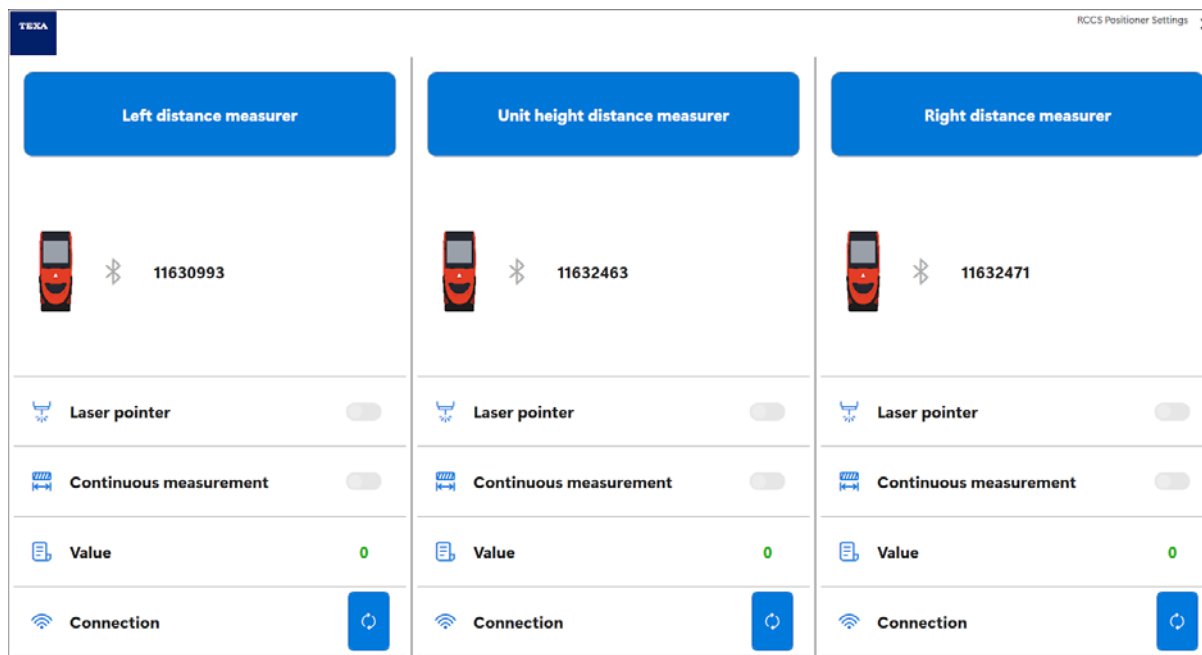

INFORMATION

The type and number of devices may vary based on the selected calibration unit.

Among the available settings there are, for example:

- *activation/deactivation of the laser pointer;*
- *activation/deactivation of the continuous measurement.*

The following is displayed:

- *connection status;*
- *measured value.*

The function allows forcing the connection with one of the devices.

Proceed as follows:

1. Press: 

43 ELECTRICAL VEHICLES



This application allows starting the diagnosis on specific systems for electric vehicles.

Proceed as follows:

1. Press:

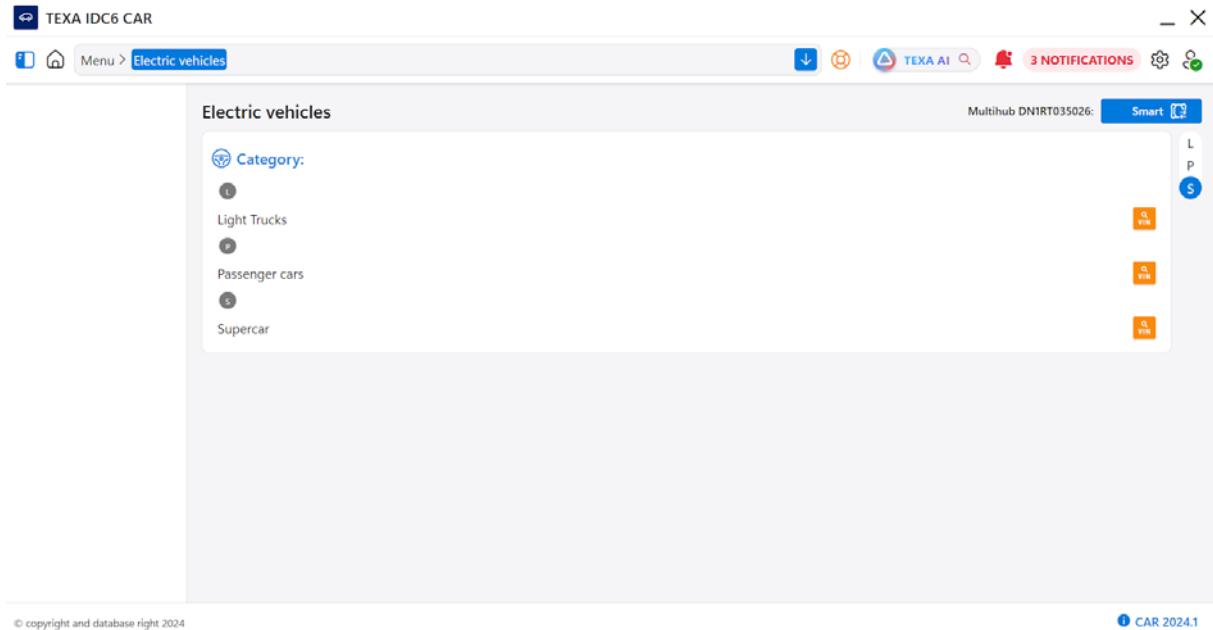

2. Carry out a complete selection.

3. Select the type of system.

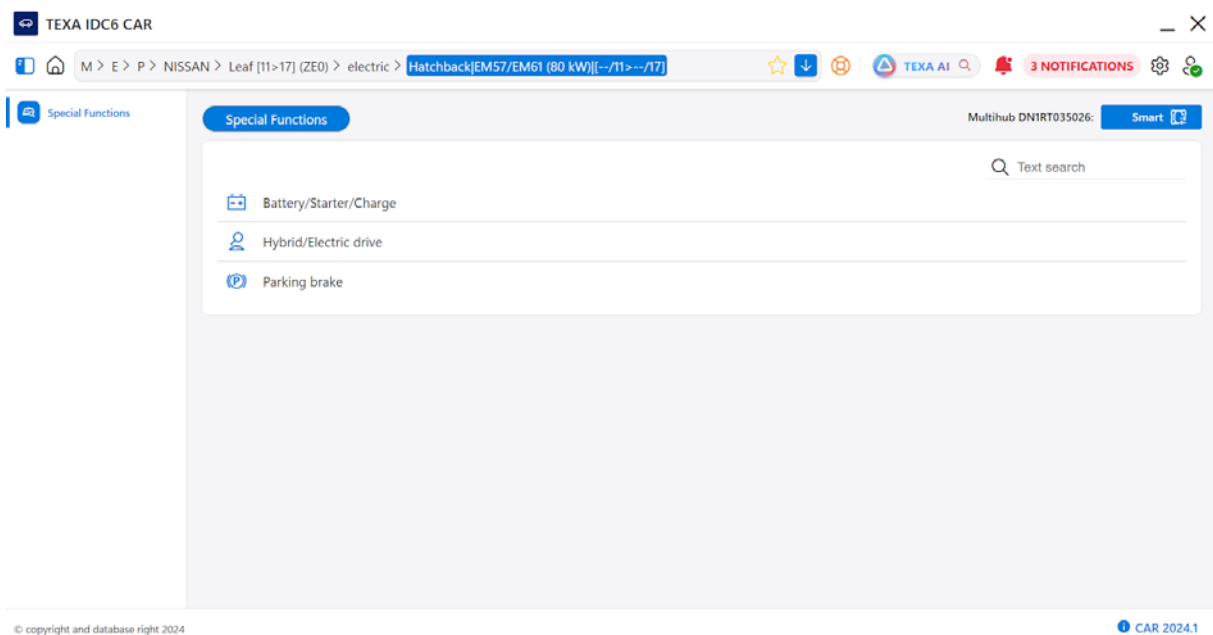

4. Select the desired operation.

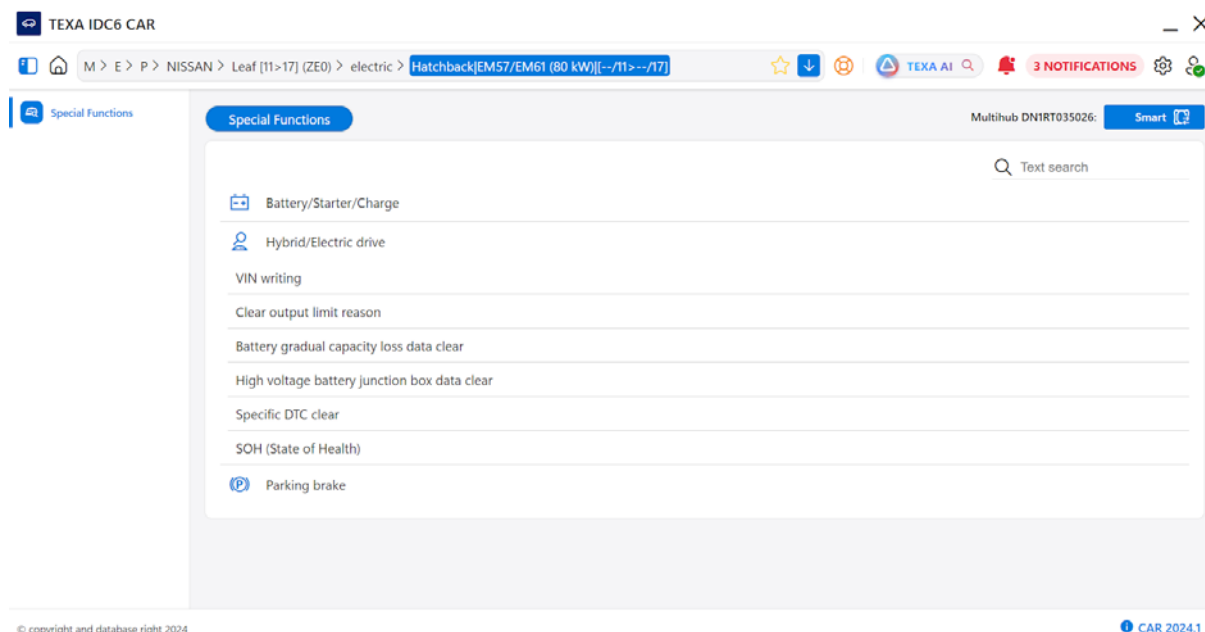

5. Select the desired variant.

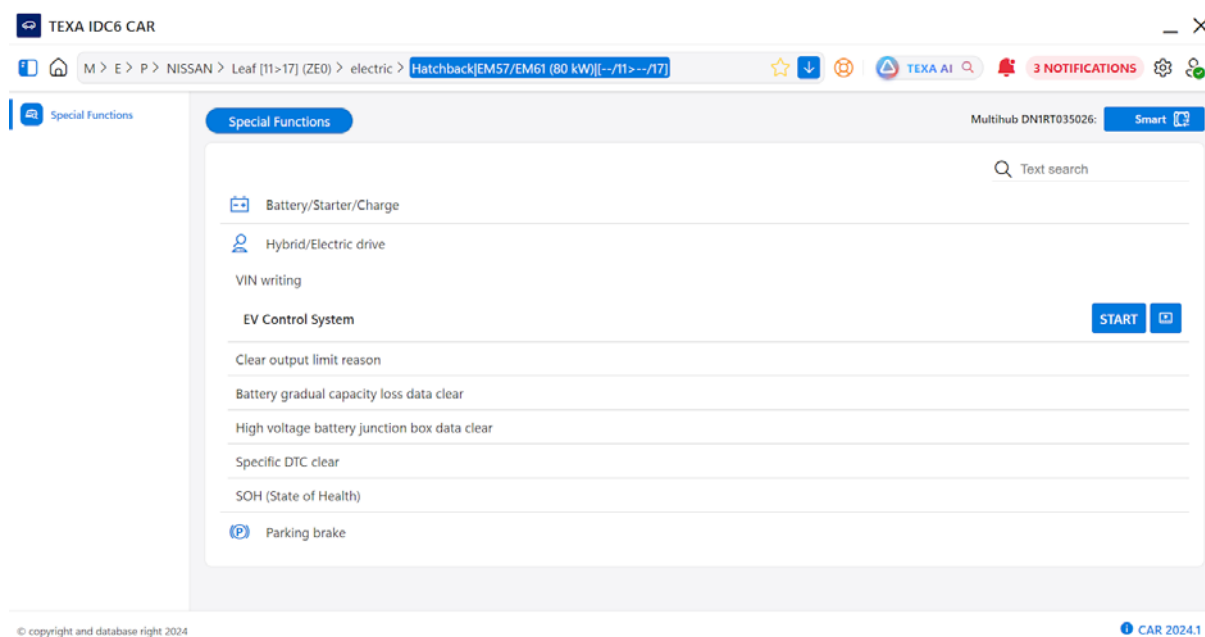

6. Press: **START**

A guided procedure is started.

7. Follow the instructions that appear on screen.

44 BATTERY REPLACEMENT



This application allows accessing the functions that let you reset the monitoring system after replacing the battery and have the control unit acknowledge the new battery.

Proceed as follows:

1. Press:

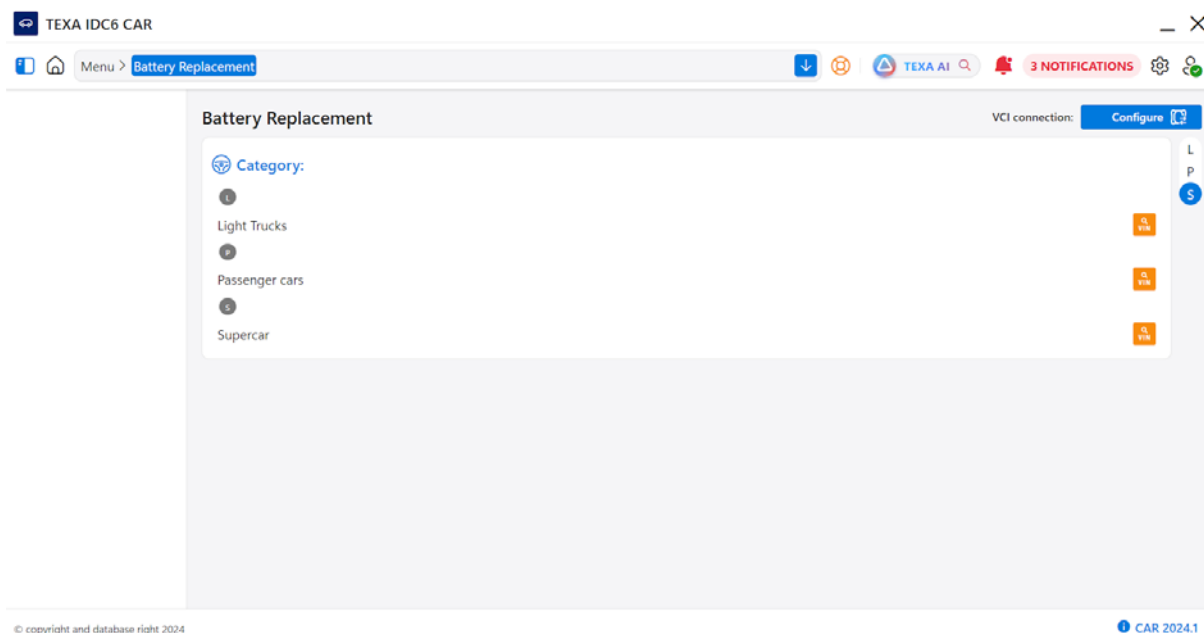

2. Carry out a complete selection.

3. Select the type of system.

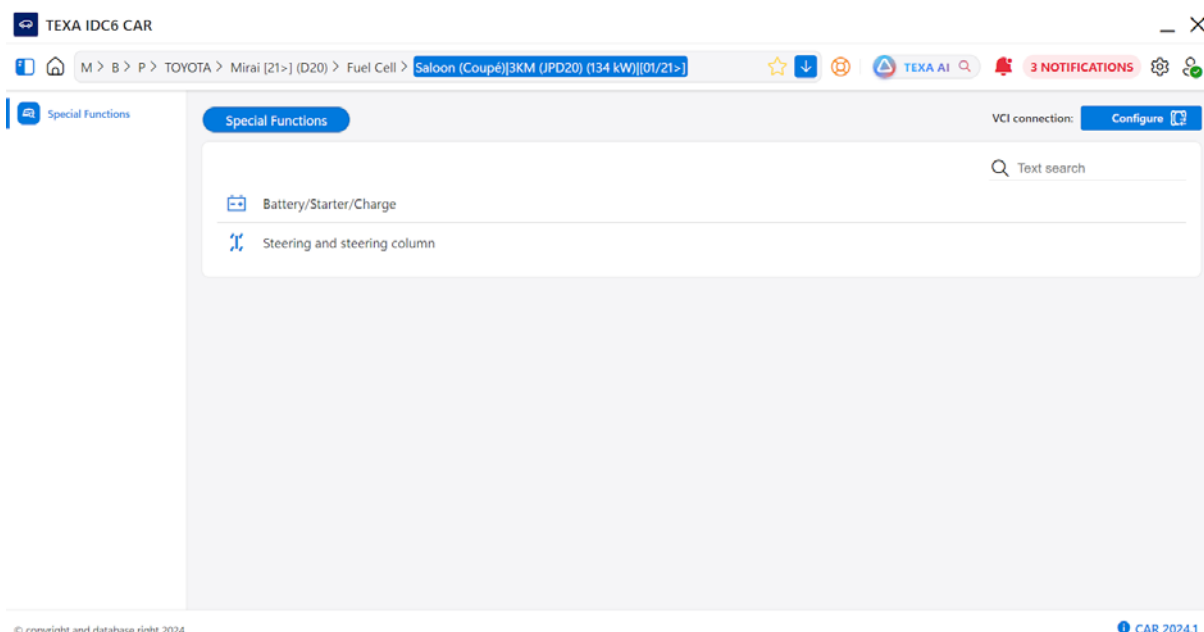

4. Select the desired operation.

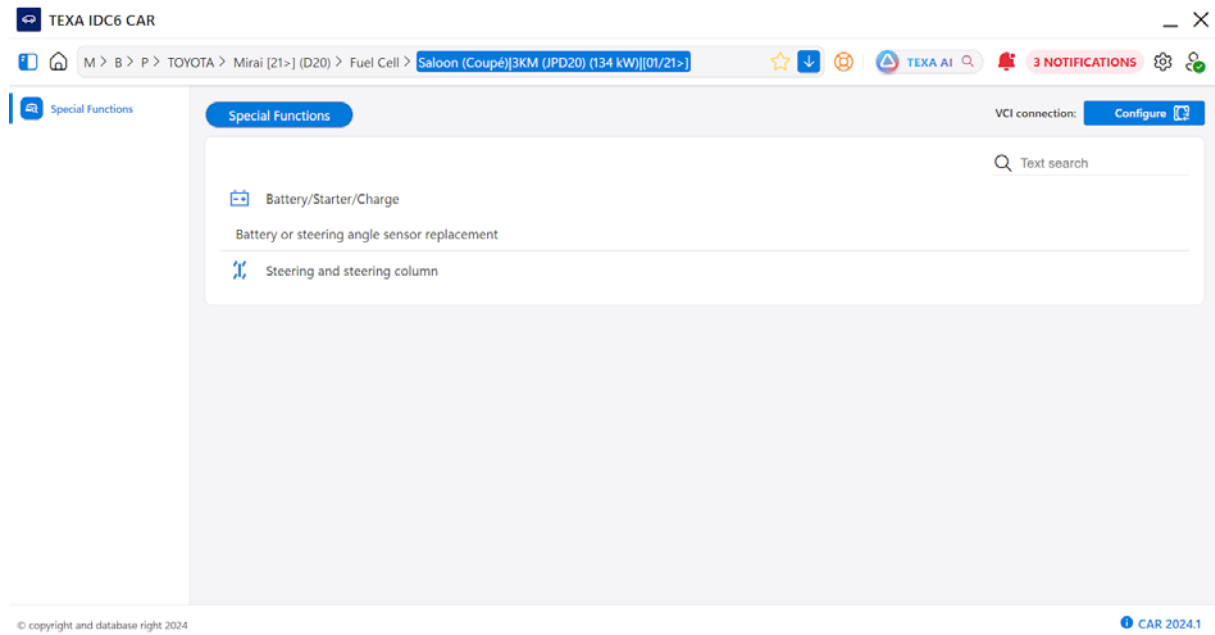

5. Select the device.

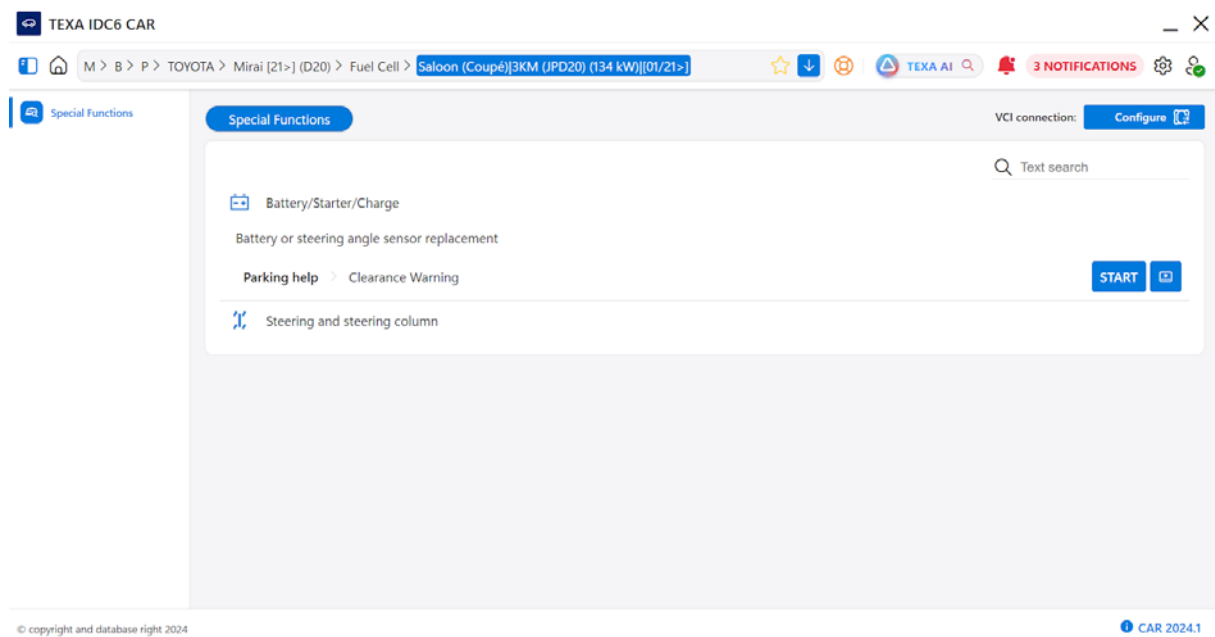

6. Press: **START**

A guided procedure is started.

7. Follow the instructions that appear on screen.

45 BRAKE PAD REPLACEMENT



This application allows accessing the functions that are useful when replacing the brake pads (e.g.: pad thickness recalibration).

Proceed as follows:

1. Press:

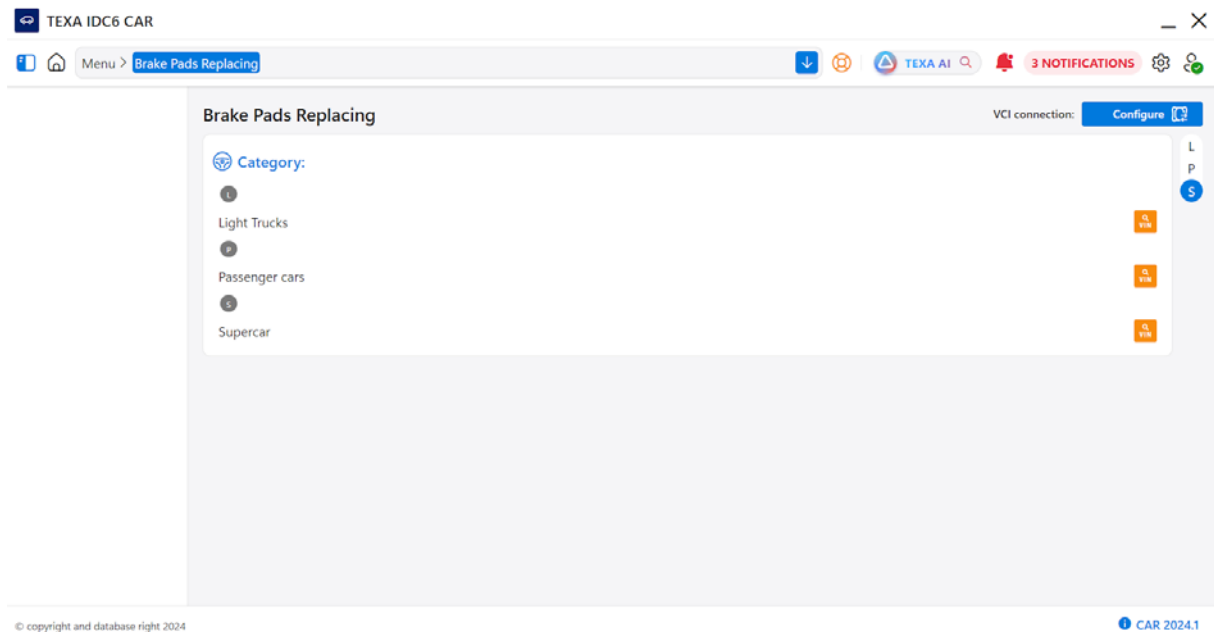

2. Carry out a complete selection.

3. Select the type of system.

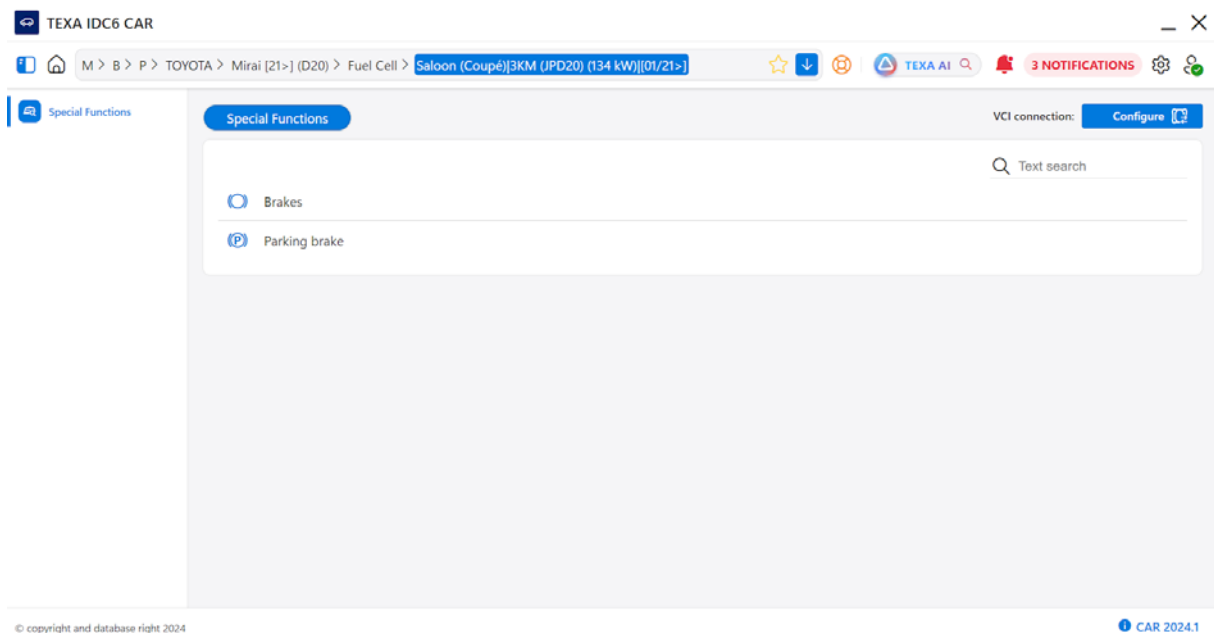

4. Select the option.

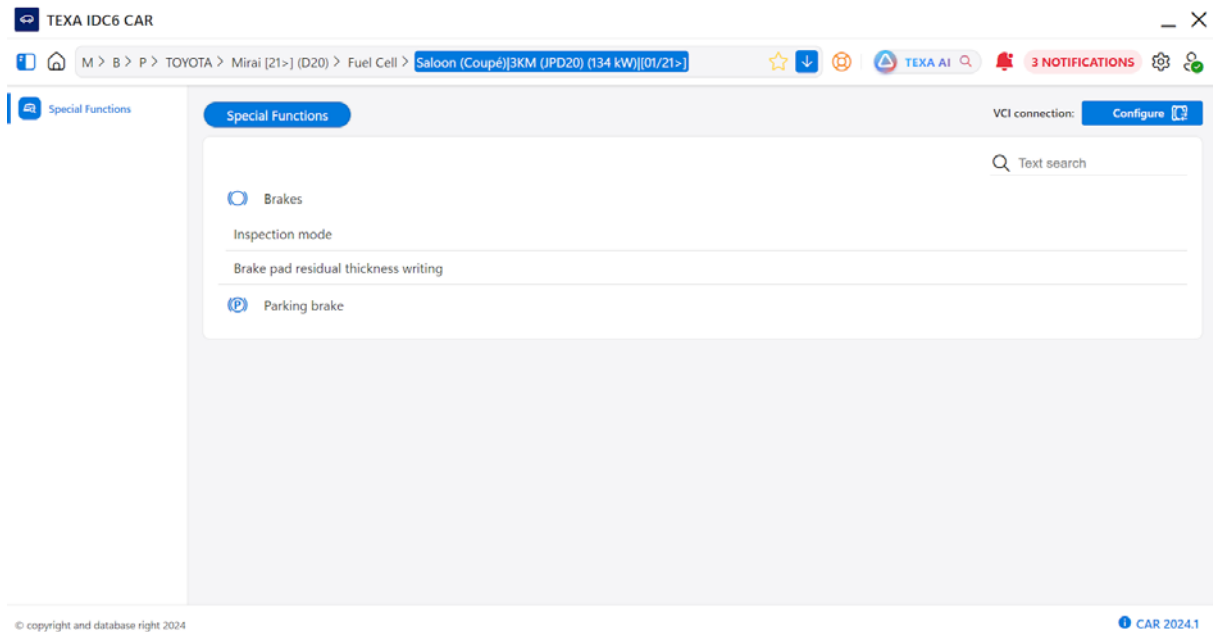

5. Select the desired variant.

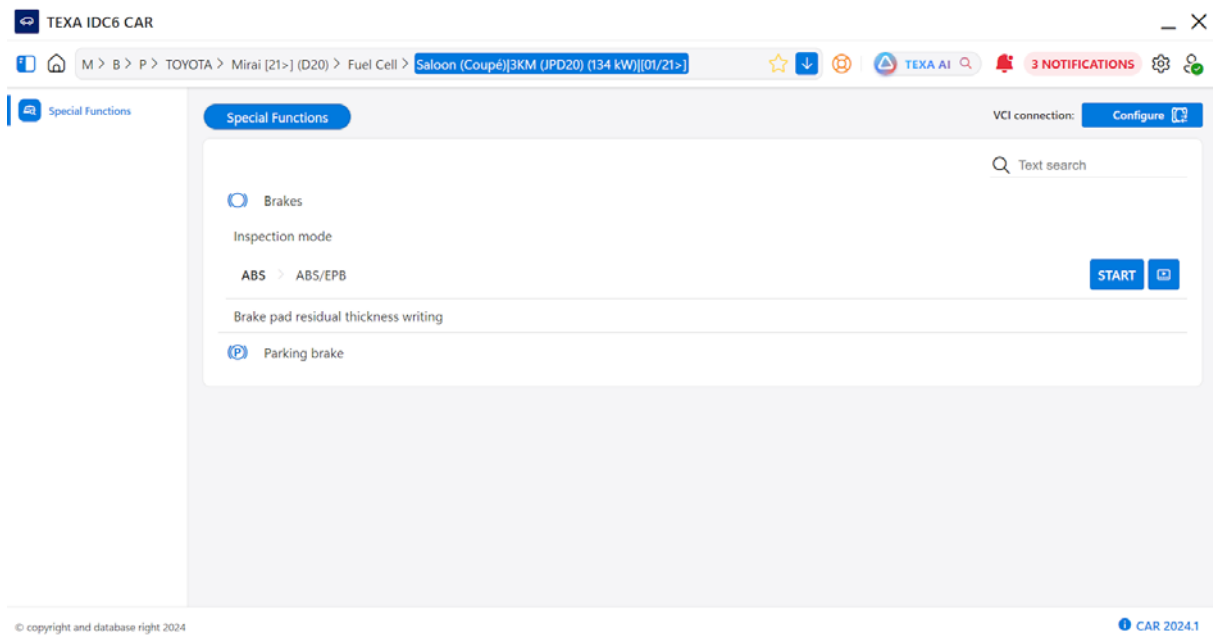

6. Press: **START**

A guided procedure is started.

7. Follow the instructions that appear on screen.

46 KEY/REMOTE CONTROL CODING



This application allows coding the keys, remote controls and immobiliser control units in case of malfunctions or need to replace them.

Proceed as follows:

1. Press:

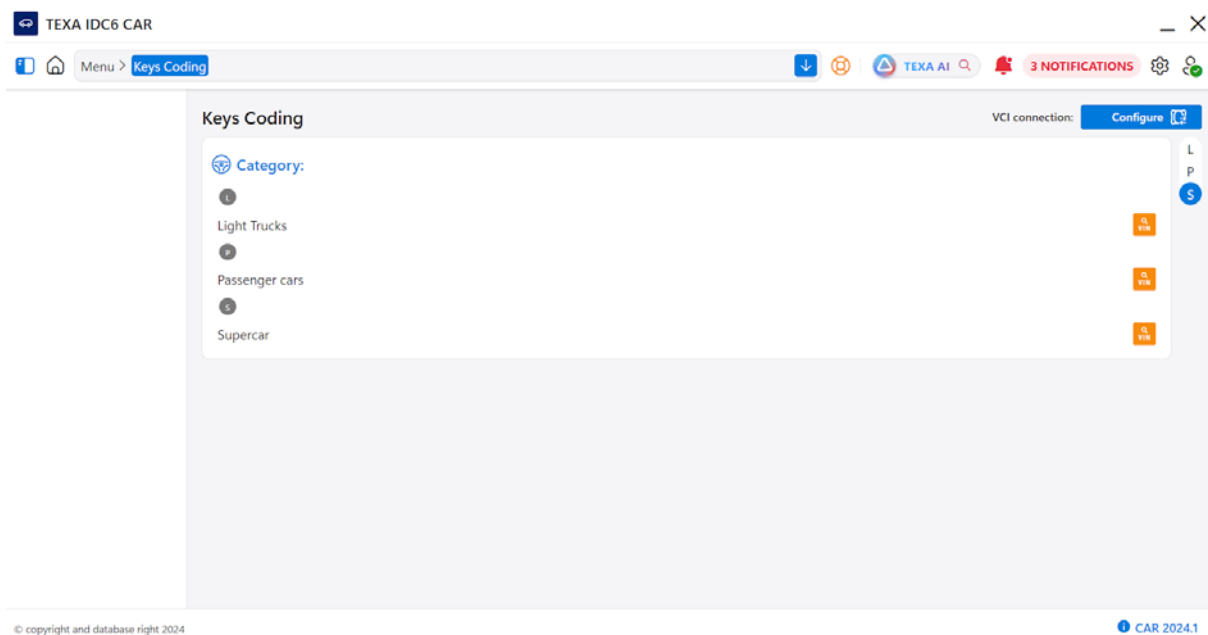

2. Carry out a complete selection.

3. Select the type of system.

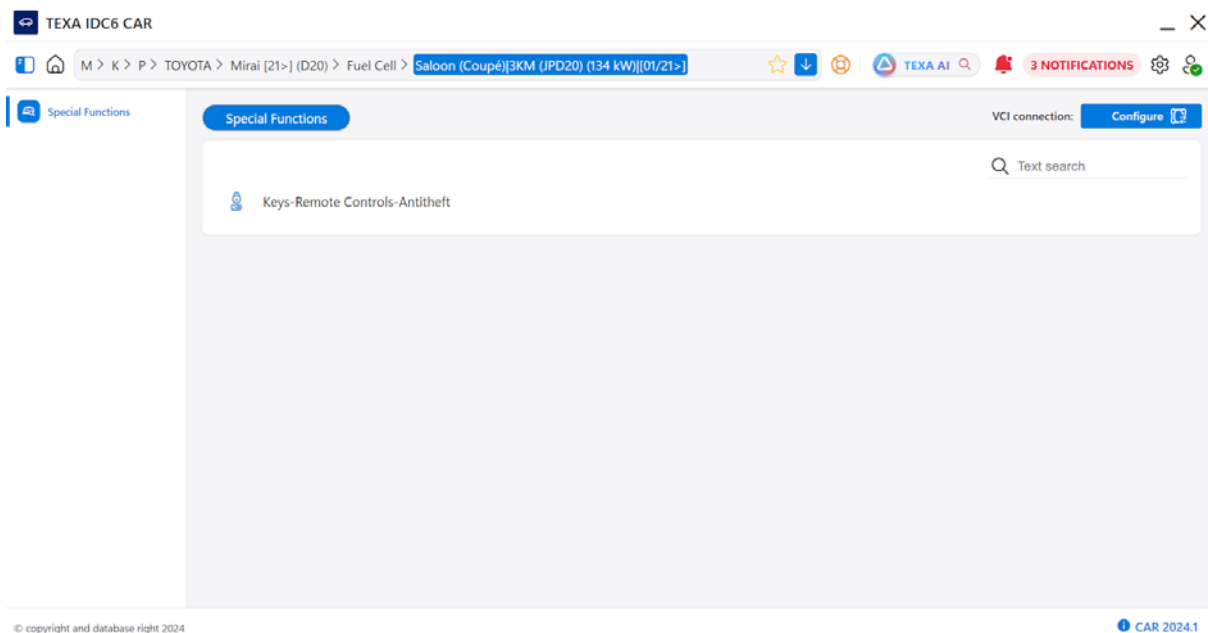

4. Select the desired operation.

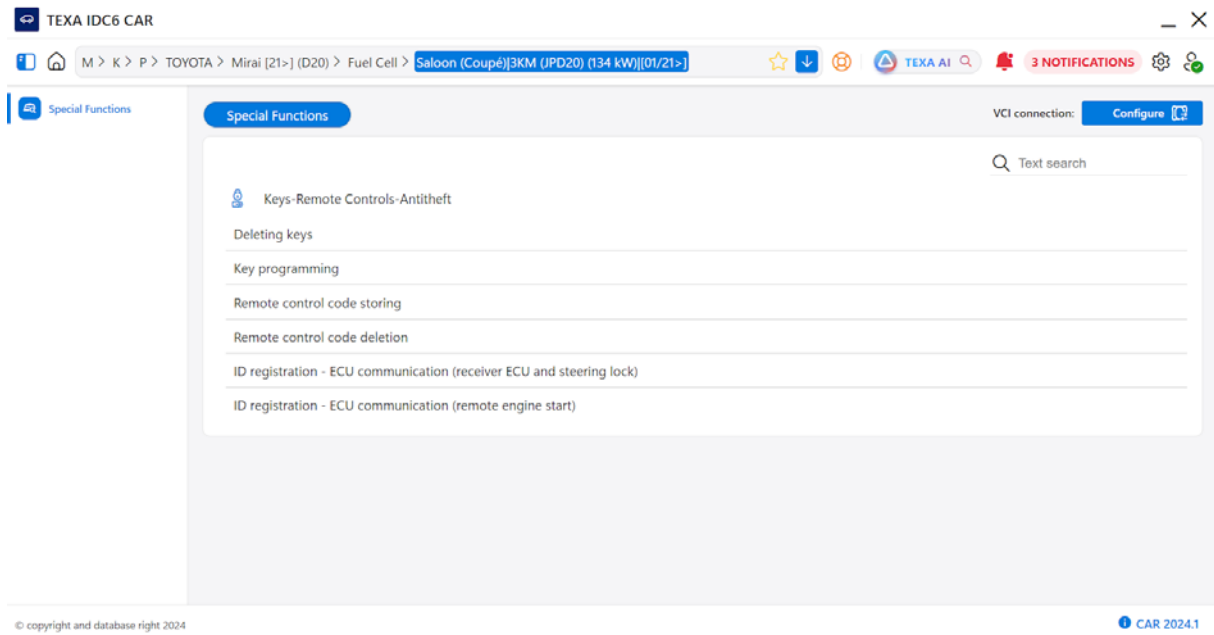

5. Select the desired variant.

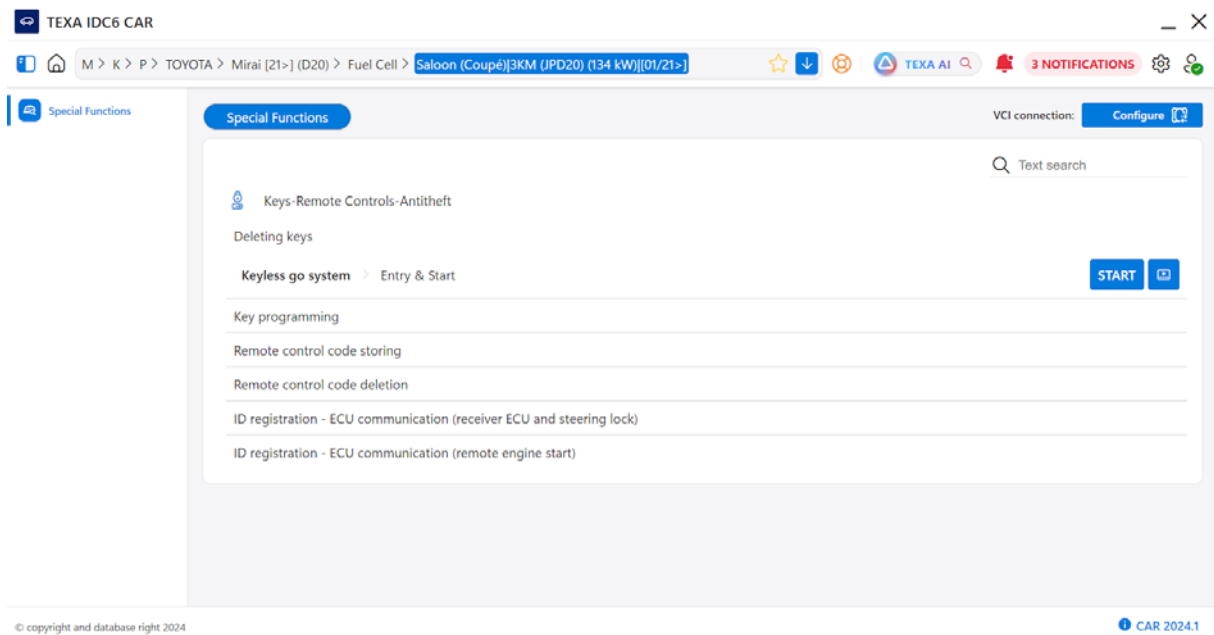

6. Press: **START**

A guided procedure is started.

7. Follow the instructions that appear on screen.

47 CHANGE LANGUAGE



This application allows changing the setting of the language of the instrument panel, multifunction display or radio.

Proceed as follows:

1. Press:

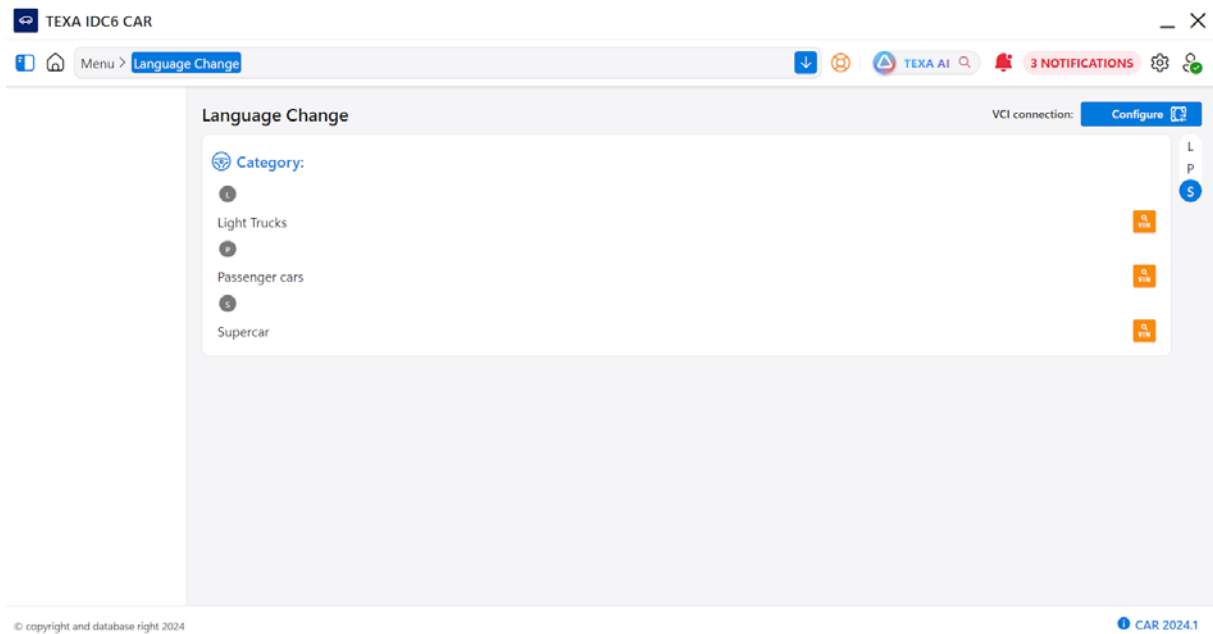

2. Carry out a complete selection.

3. Select the type of system.

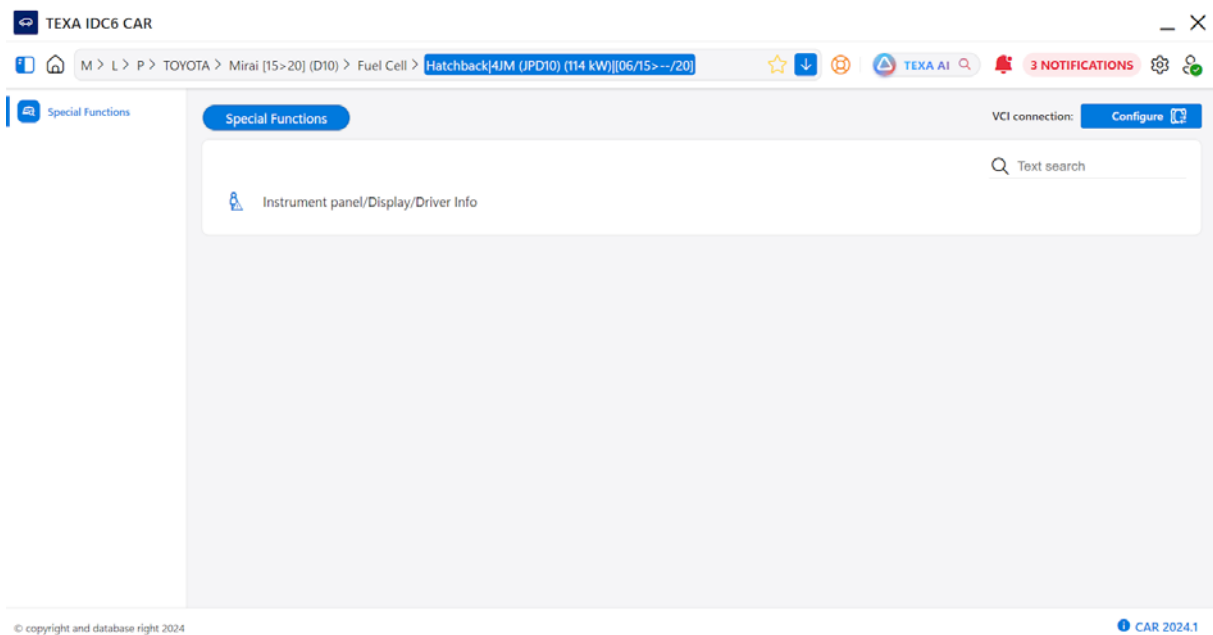

4. Select the desired operation.

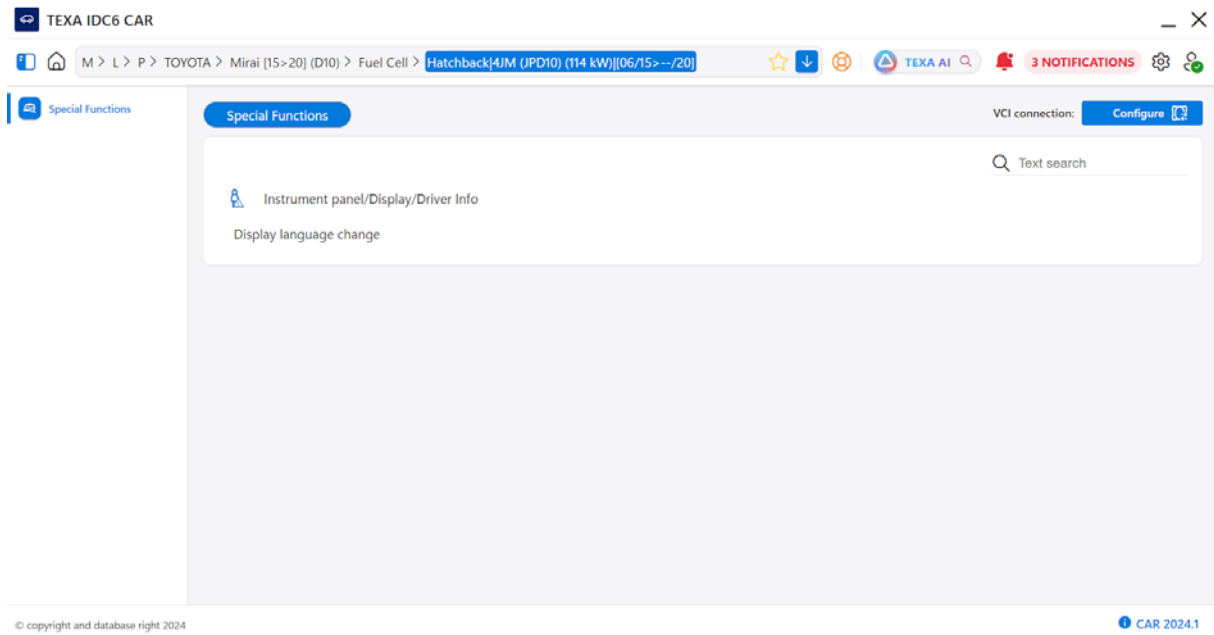

5. Select the desired device.

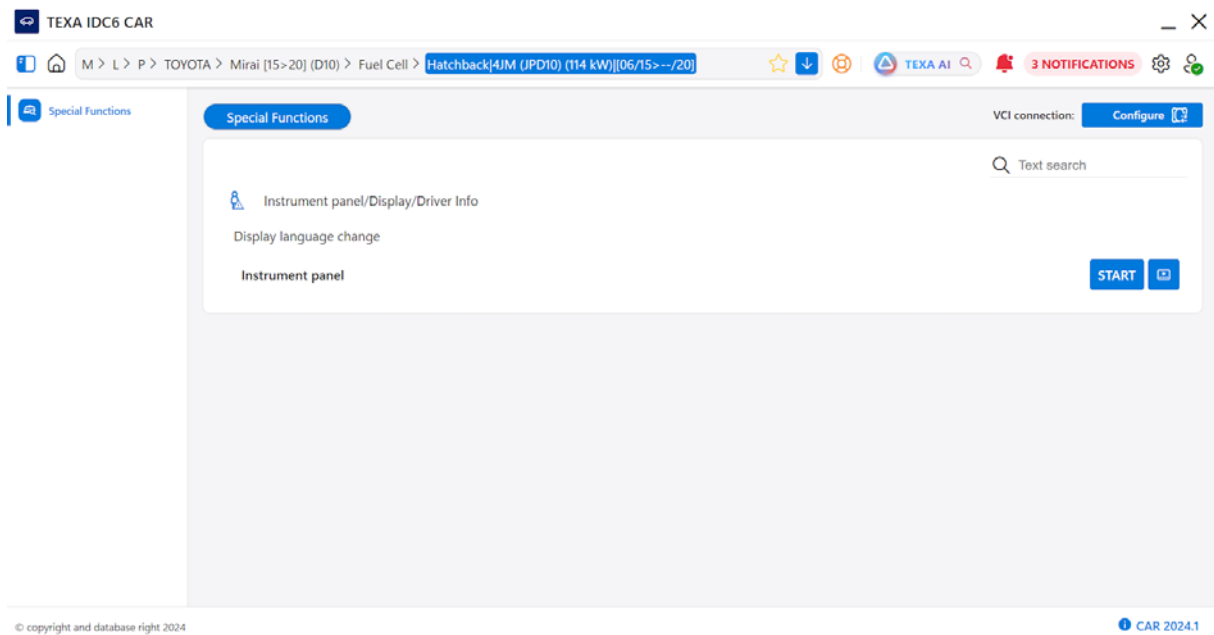

6. Press: **START**

A guided procedure is started.

7. Follow the instructions that appear on screen.

48 TPMS



This application allows launching the TPMS sensor maintenance function.

Proceed as follows:

1. Press:

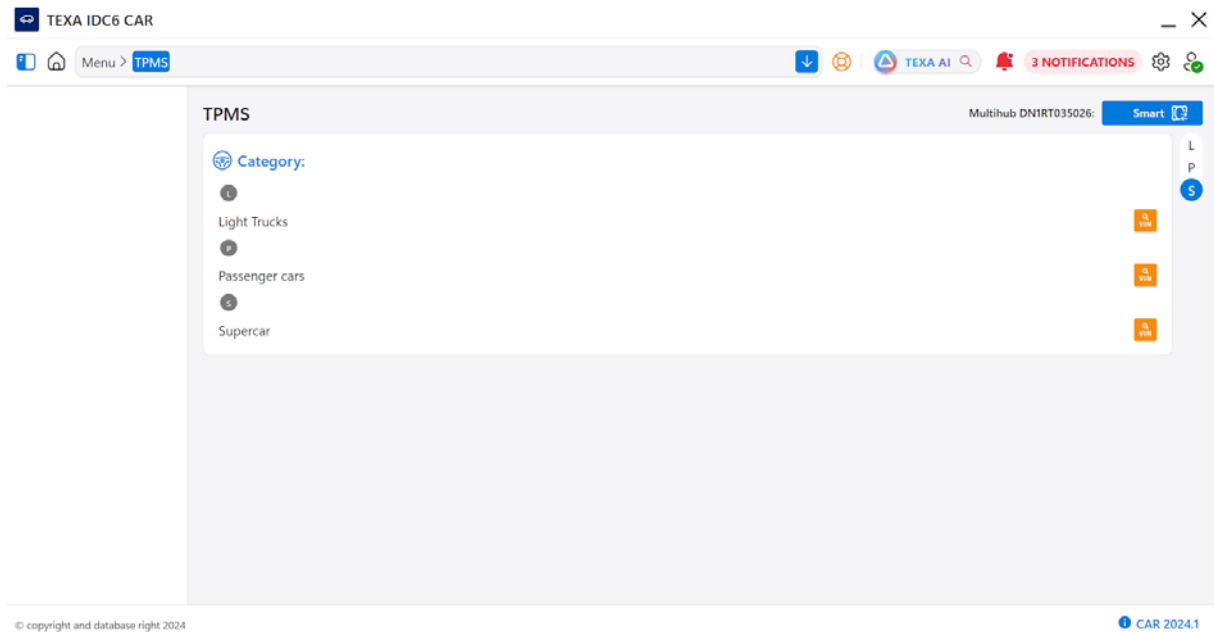

2. Carry out a complete selection.

3. Select the type of system.

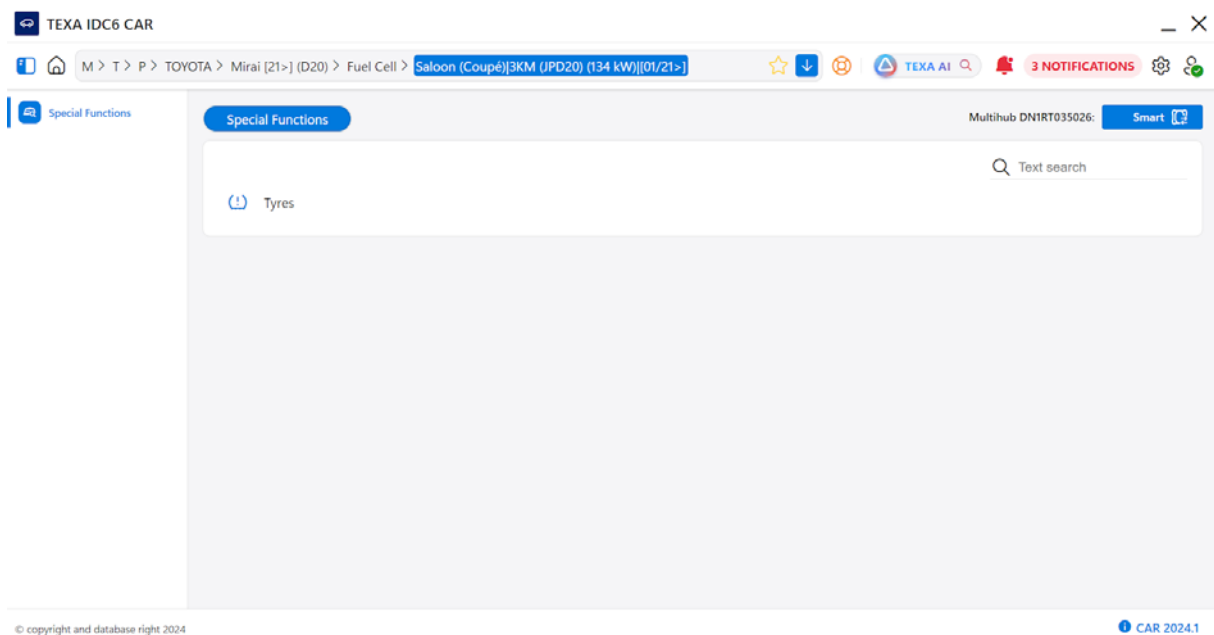

4. Select the desired operation.

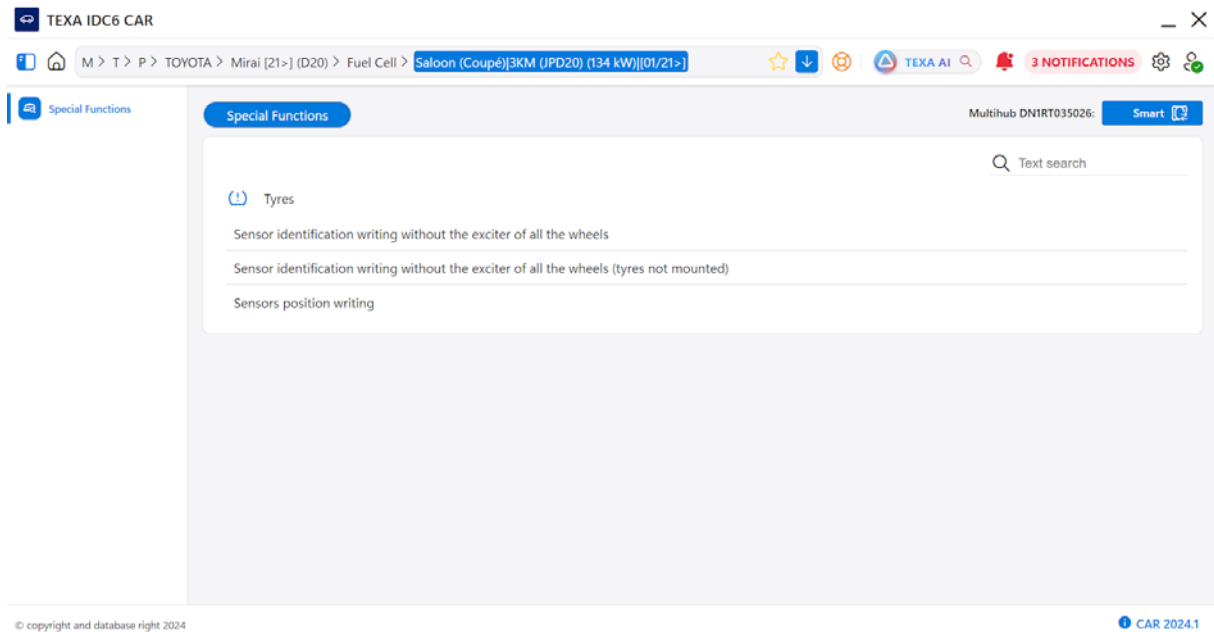

5. Select the desired variant.

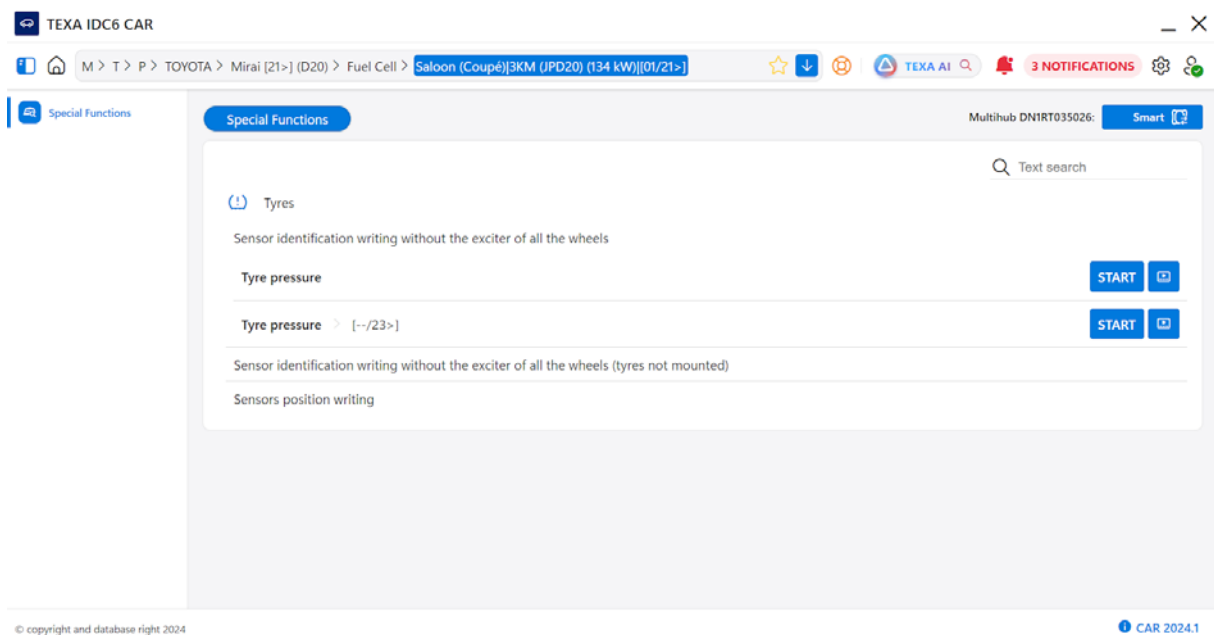

6. Press: **START**

A guided procedure is started.

7. Follow the instructions that appear on screen.

49 TRANSPORTATIONMODE PROGRAMMING



This application allows quickly activating all the vehicle's functions by changing the status “Factory mode” to “Customer Mode”.

Proceed as follows:

1. Press:

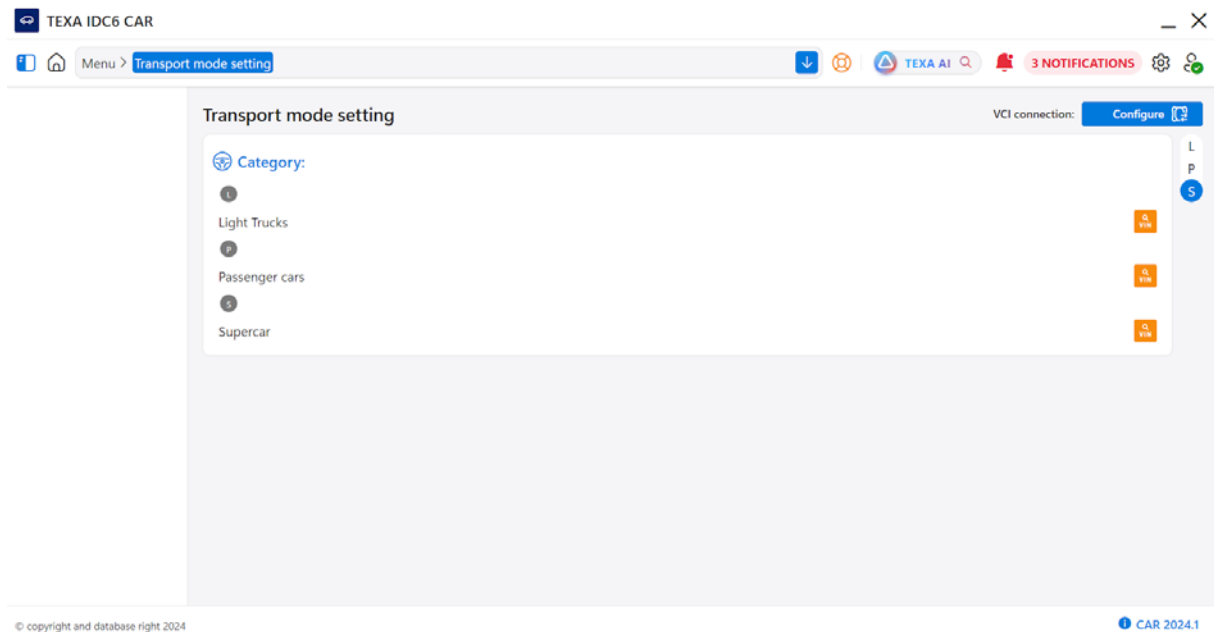

2. Carry out a complete selection.

3. Select the type of system.

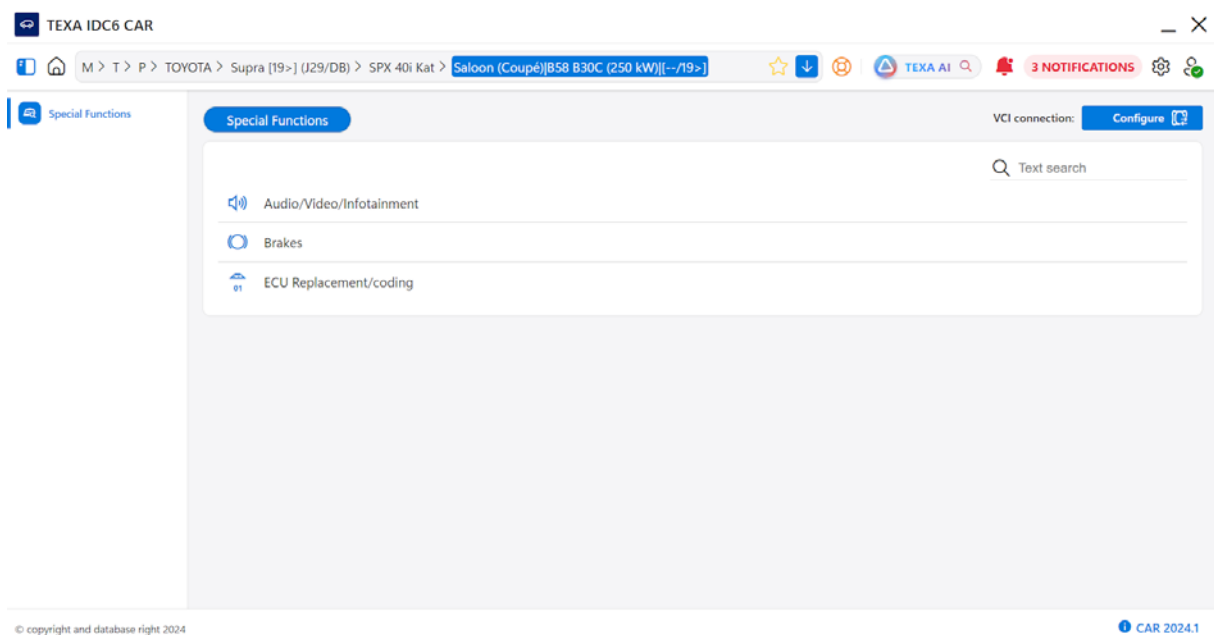

4. Select the desired operation.

The screenshot shows the TEXA IDC6 CAR software interface. The breadcrumb navigation at the top reads: M > T > P > TOYOTA > Supra [19>] (J29/DB) > SPX 40i Kat > Saloon (Coupé)[B58 B30C (250 kW)][[-/19>]. The main content area is titled "Special Functions" and contains a list of operations: Audio/Video/Infotainment, Brakes, ECU Replacement/coding, Transport mode, and Transport mode delete. A search bar labeled "Text search" is located in the top right of the menu. In the top right corner of the interface, there is a "VCI connection: Configure" button. The footer contains the text "© copyright and database right 2024" on the left and "CAR 2024.1" on the right.

5. Select the desired variant.

This screenshot is similar to the previous one but shows the "Service system" variant selected under the "Transport mode" category. The breadcrumb navigation is the same. The "Service system" entry is expanded to show "(CBS) Reset and Data Correction". A blue "START" button and a small icon are visible to the right of this entry. The rest of the interface, including the search bar and footer, remains the same.

6. Press: **START**

A guided procedure is started.

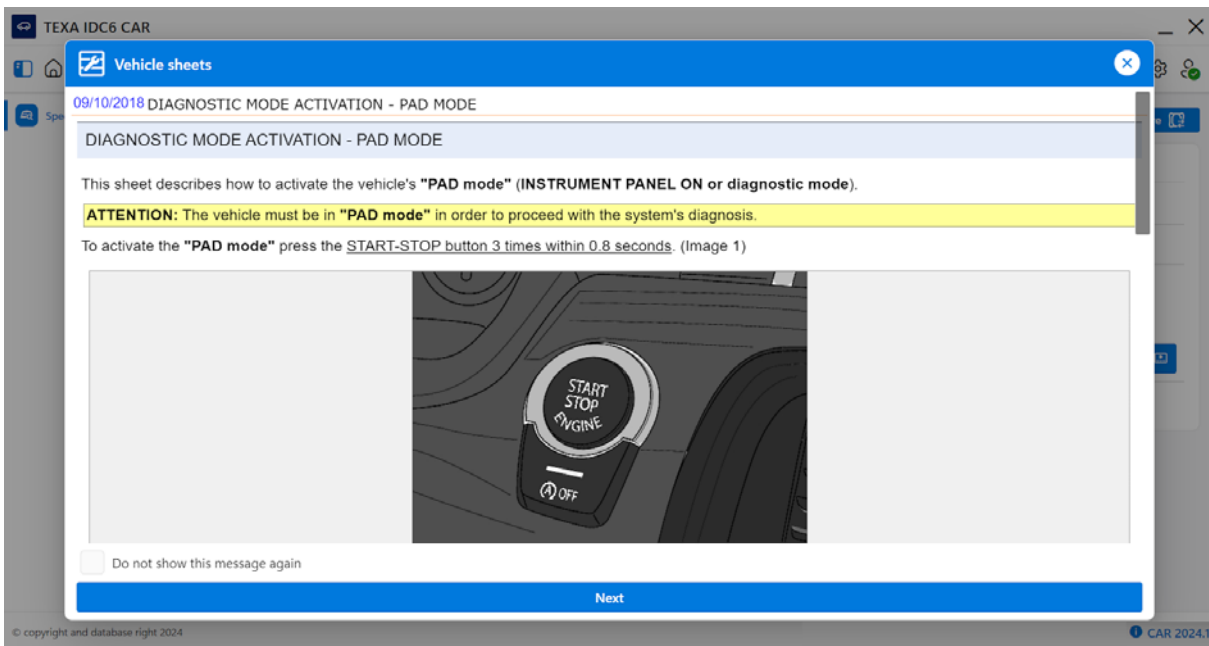

8. Press:**Next**

7. Follow the instructions that appear on screen.

50 PARTICULATE FILTER/CATALYST REGENERATION



This application allows accessing the particulate filter and catalyst regeneration functions. Proceed as follows:

1. Press: 

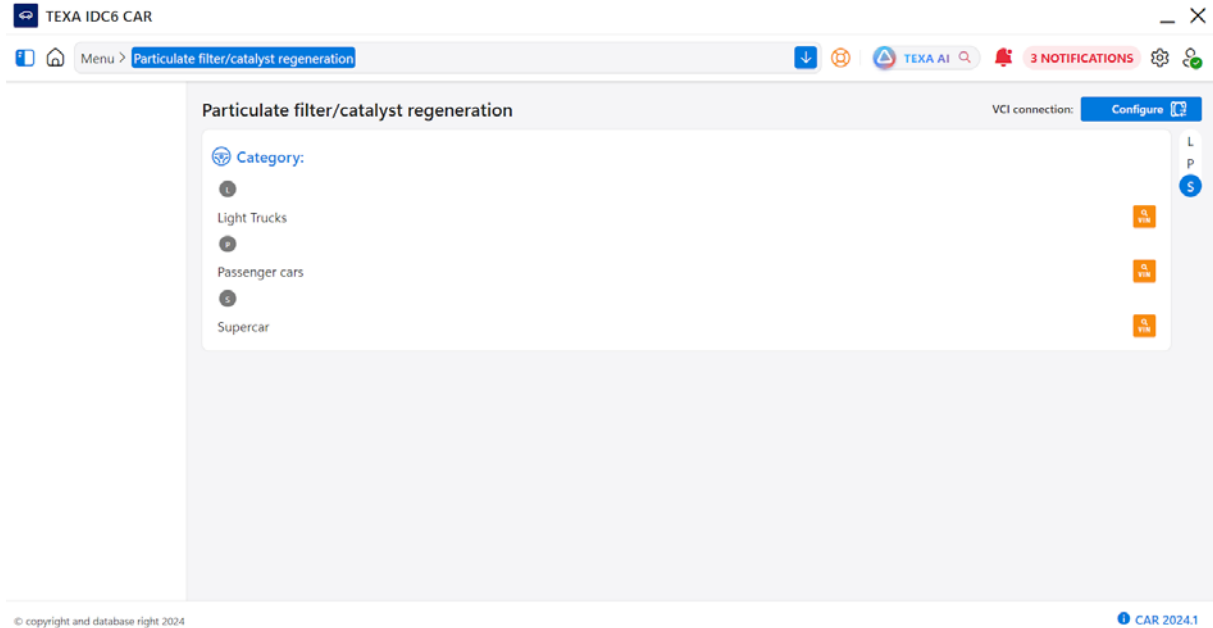

2. Carry out a complete selection.
3. Select the type of system.

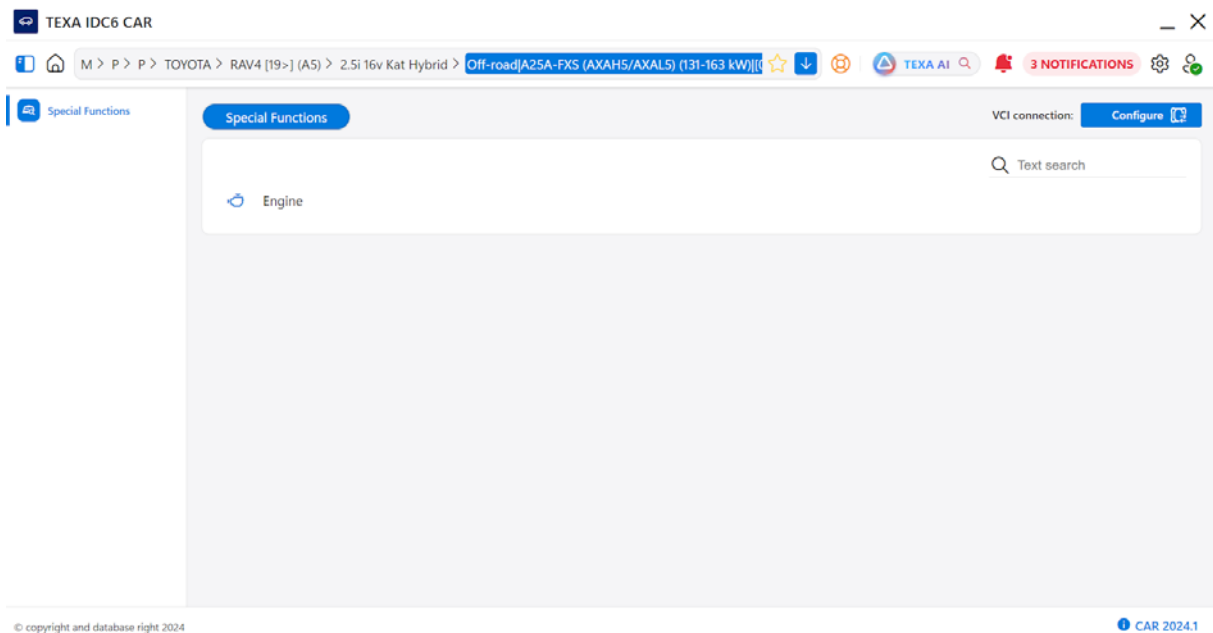

4. Select the desired operation.

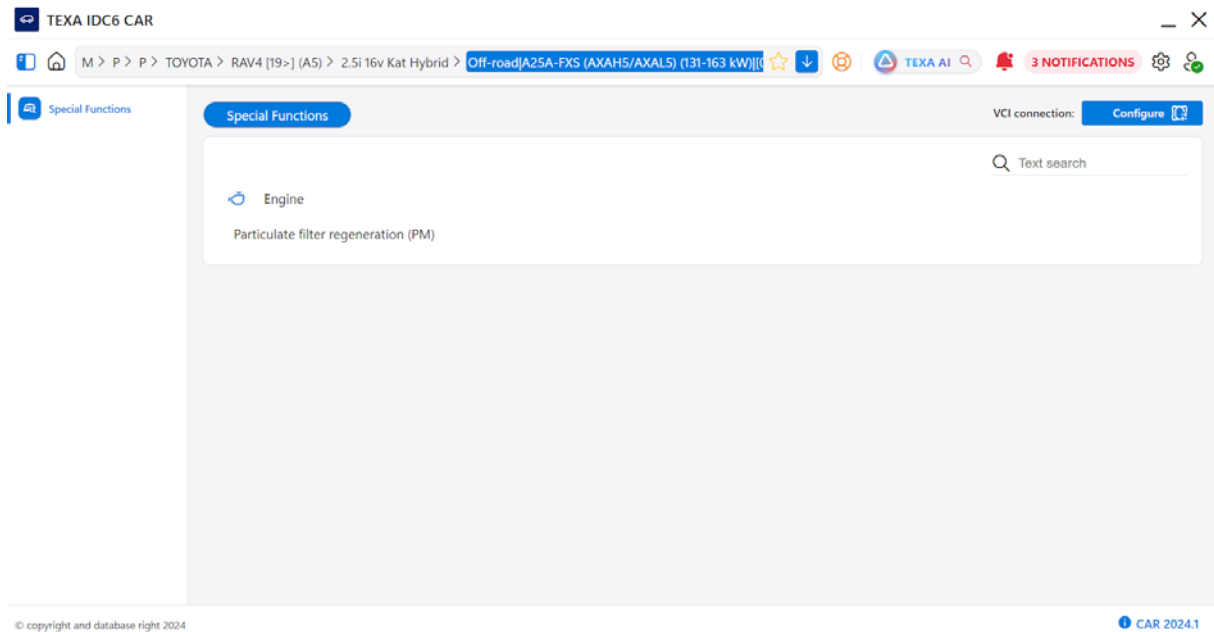

5. Select the desired variant.

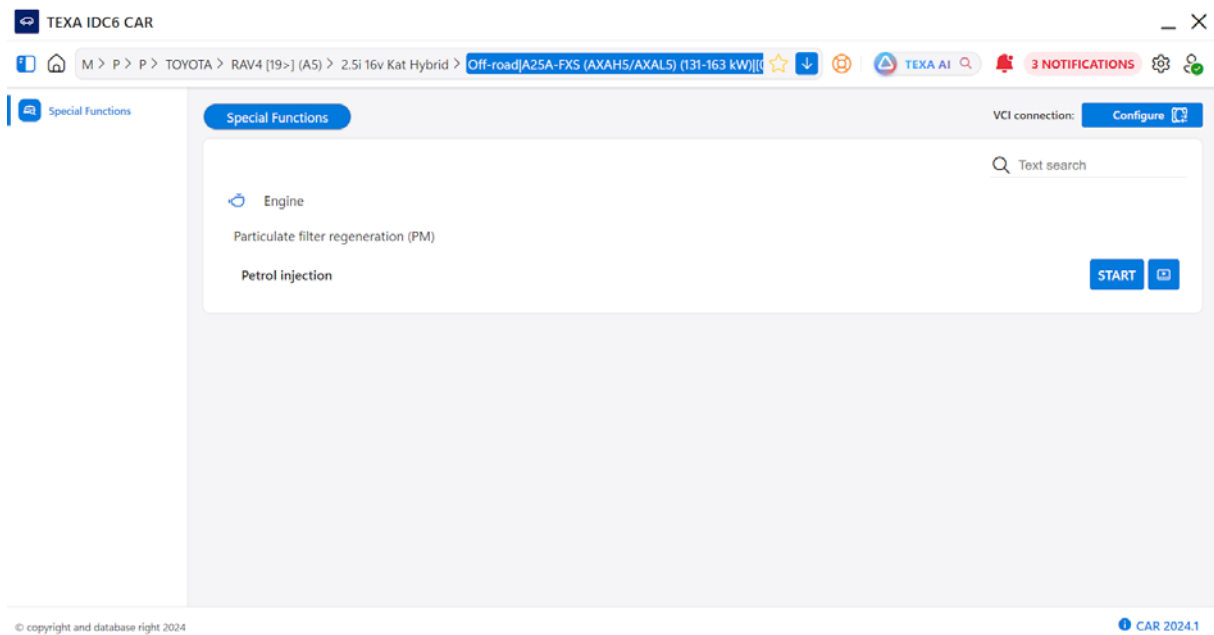

6. Press: **START**

A guided procedure is started.

7. Follow the instructions that appear on screen.

51 DRIVER ASSISTANCE



This application allows accessing the adaptation and programming functions related to the control units dedicated to the driver's comfort and safety.

Proceed as follows:

1. Press:

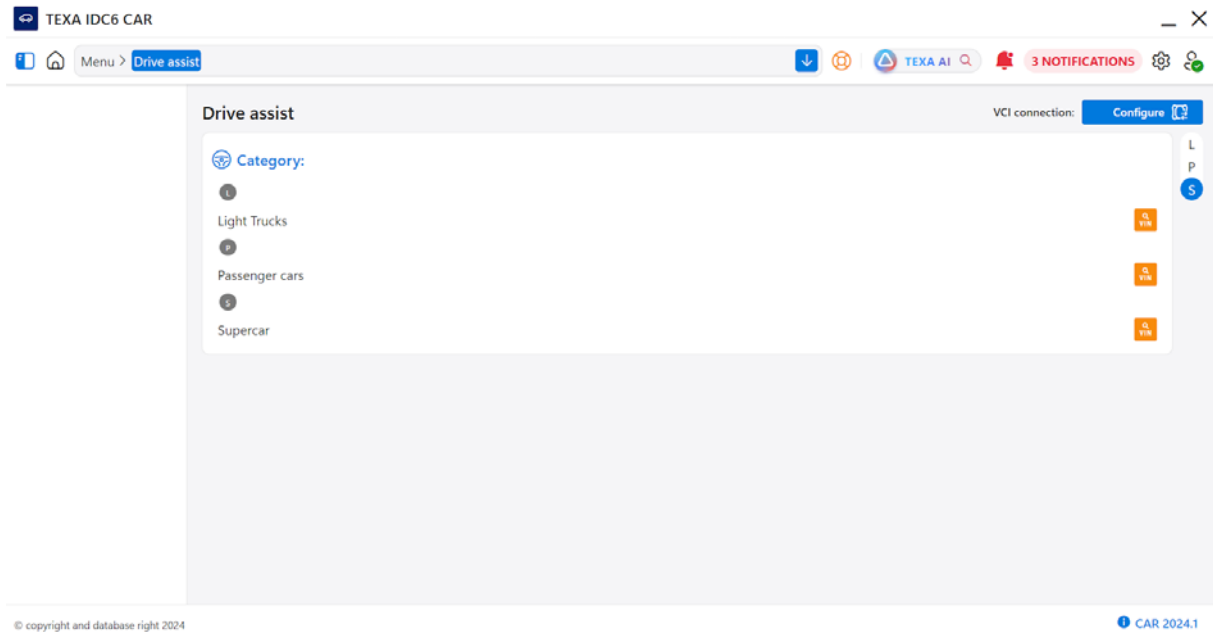

2. Carry out a complete selection.

3. Select the operation or type of system.

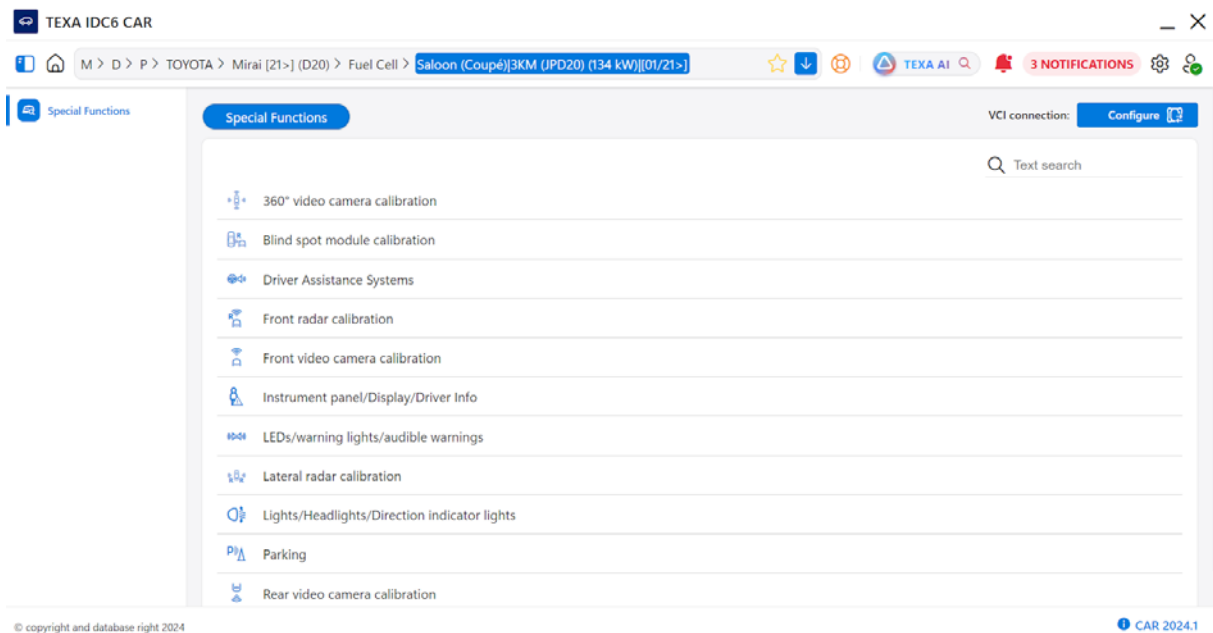

4. Select the desired option.

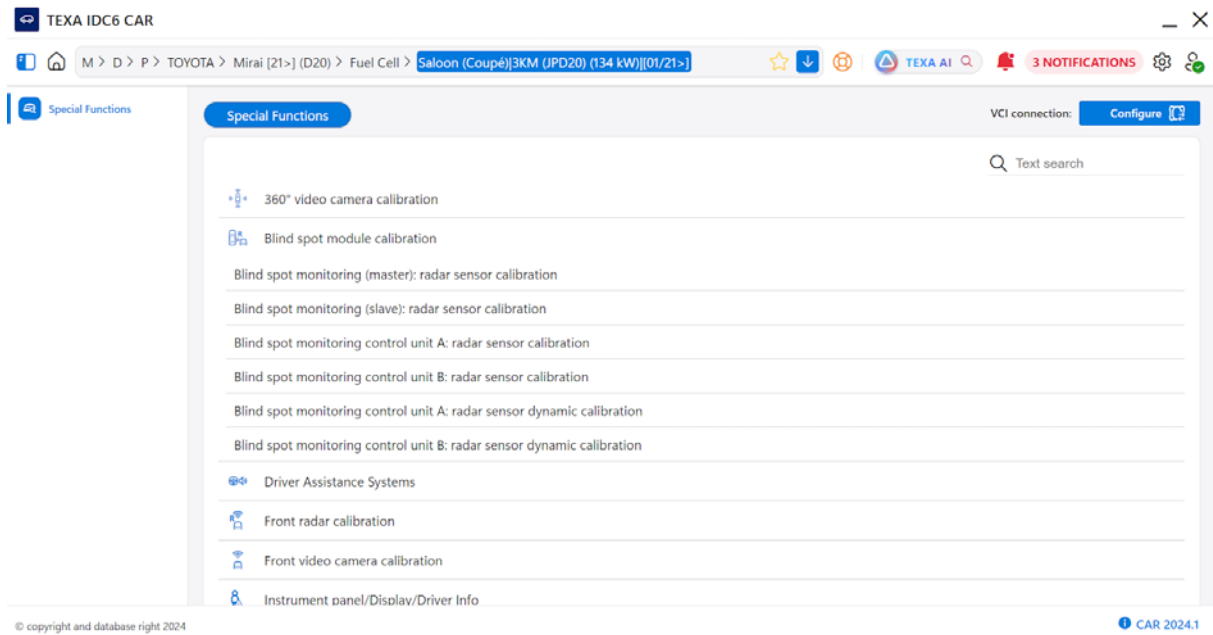

5. Select the desired variant.

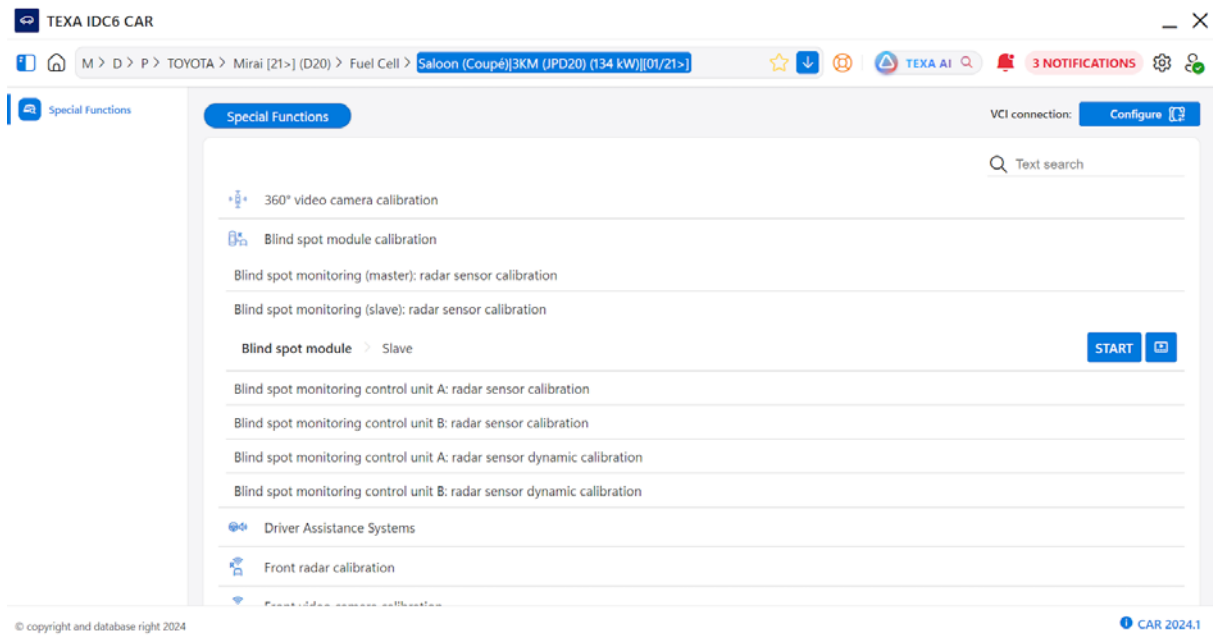

6. Press: **START**

A guided procedure is started.

7. Follow the instructions that appear on screen.

52 PARK ASSIST



This application allows accessing the parking sensor programming functions.

Proceed as follows:

1. Press:

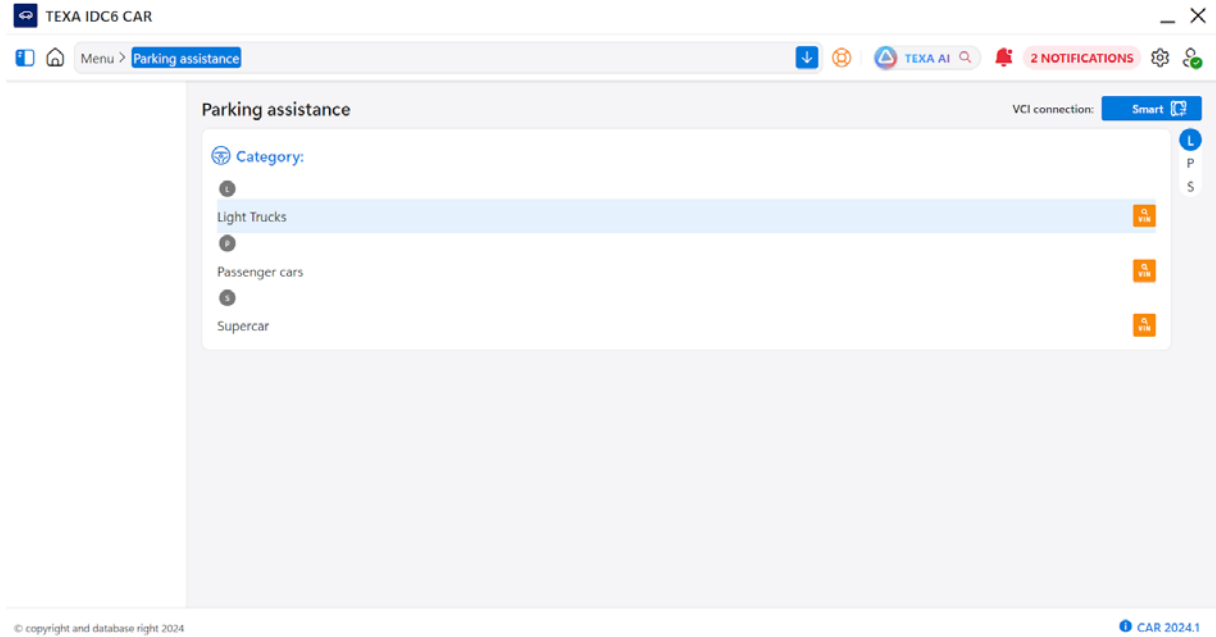

2. Carry out a complete selection.

3. Select the type of system.

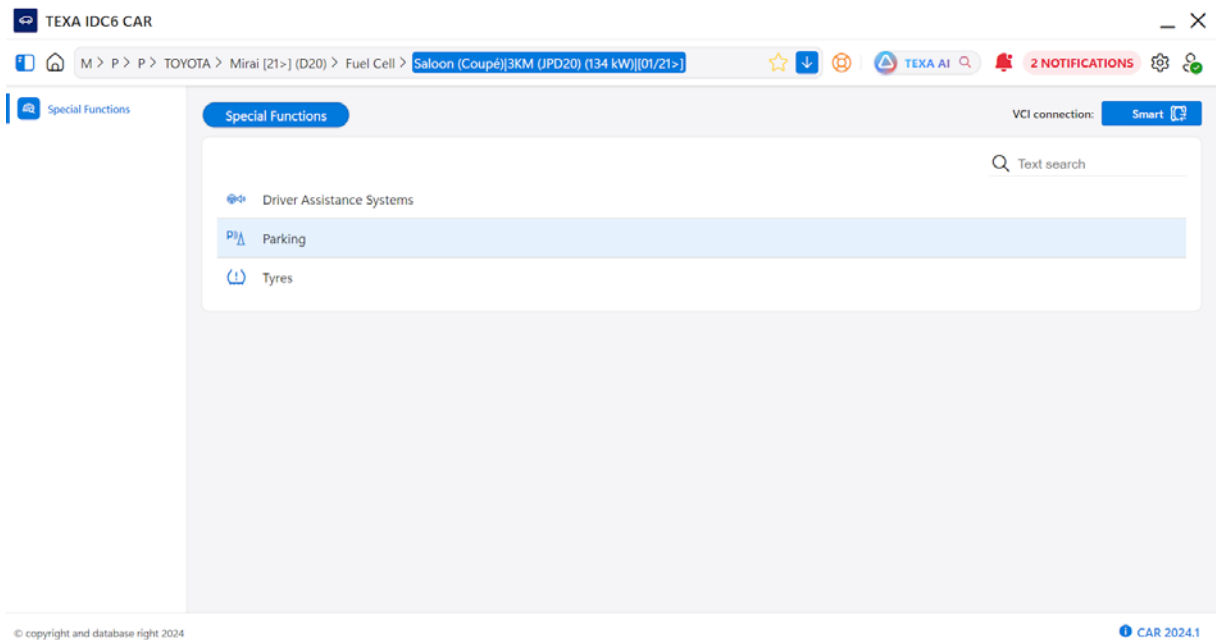

4. Select the desired operation.

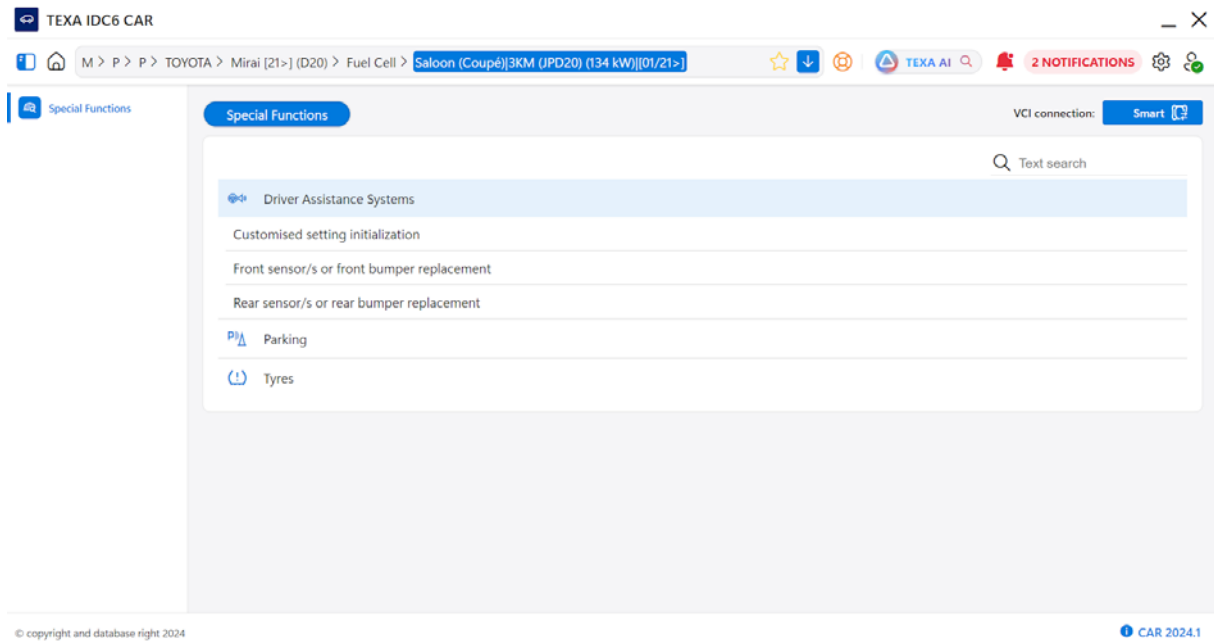

5. Select the desired variant.

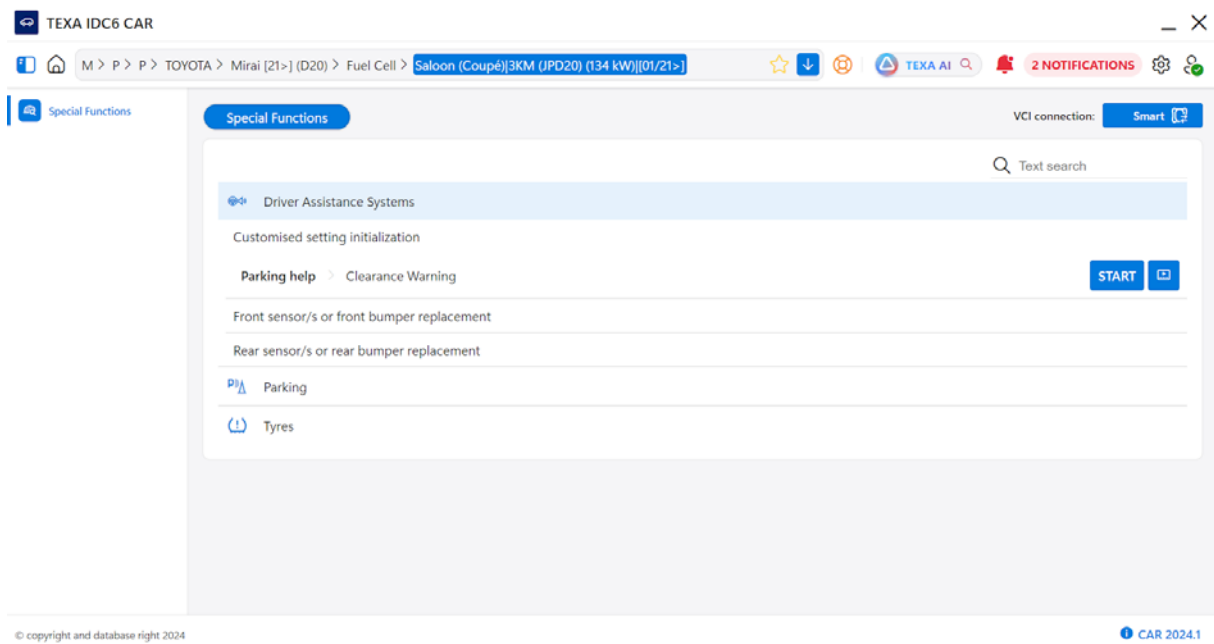

6. Press: **START**

A guided procedure is started.

7. Follow the instructions that appear on screen.



53 MEASUREMENTS SECTION

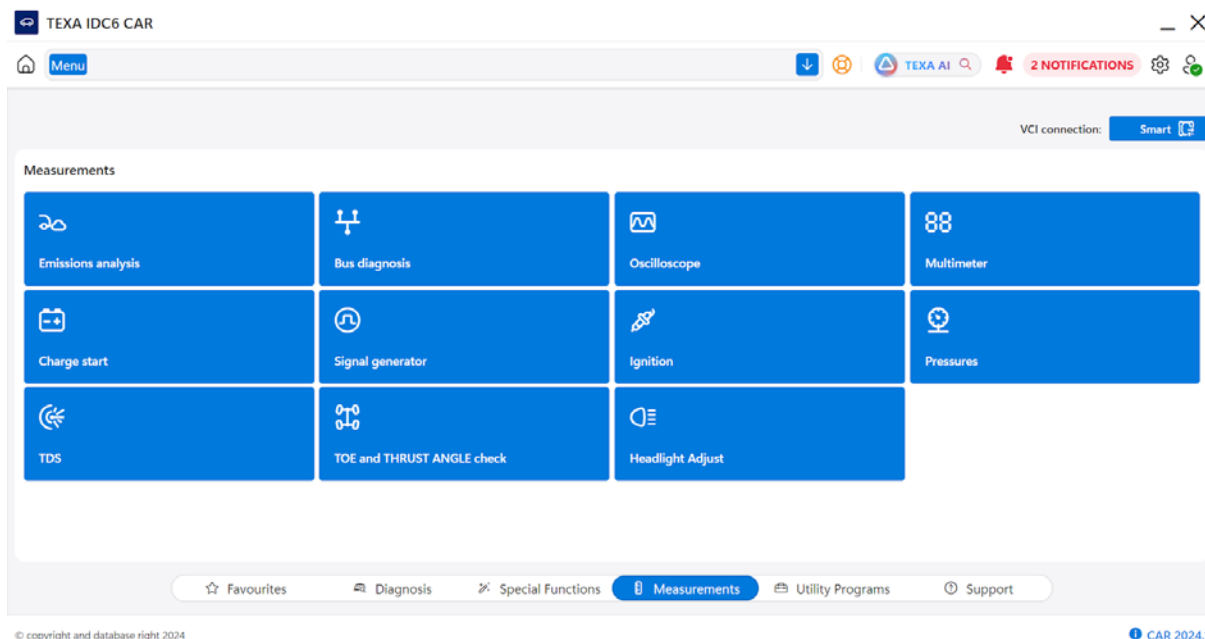

This section gathers the measuring functions.



Icon	Name	Description
	Emissions analysis	It allows launching the specific software program for the analysis of the exhaust gases of vehicles with petrol, LPG and methane engines and the opacity measurements on vehicles equipped with a diesel engine.
	Bus diagnosis	It allows launching the function needed to analyse the CAN networks.
	Oscilloscope	It allows displaying graphically the trend of an electric signal over time.
	Multimeter	It allows measuring voltage, current, resistance and performing diode tests and short-circuit searches.
	Charge start	It allows verifying the efficiency of the battery, the battery's recharge (alternator) and of the electrical components involved in the engine ignition phase (starter motor),
	Signal generator	It allows simulating the input and output signals of the electronic control units used in vehicles.
	Power on	It allows launching the function needed to measure high voltages.
	Pressures	It allows launching the function needed to measure pressure.

	TDS	It allows launching the tyre and brake disc wear measurement software.
	TOE and THRUST ANGLE check	It allows activating the software that checks the vehicle's toe and thrust angle.
	Headlight adjust	It allows launching the diagnostic software for the headlight tester.

INFORMATION

Some functions may not be available for all the environments or on all the platforms.

54 BUS DIAGNOSIS



This function allows launching the application for the analysis of the CAN networks.

The types of BUSES on which you can perform the diagnosis are:

- *Two-wire CAN with HIGH SPEED BUS.*
- *Two-wire CAN with LOW SPEED BUS.*
- *SINGLE WIRE CAN with LOW SPEED BUS.*

The LOW SPEED BUS reaches a transmission speed of 125 kbit/s while the HIGH SPEED BUS reaches a transmission speed of 1 Mbit/s.

The function allows checking:





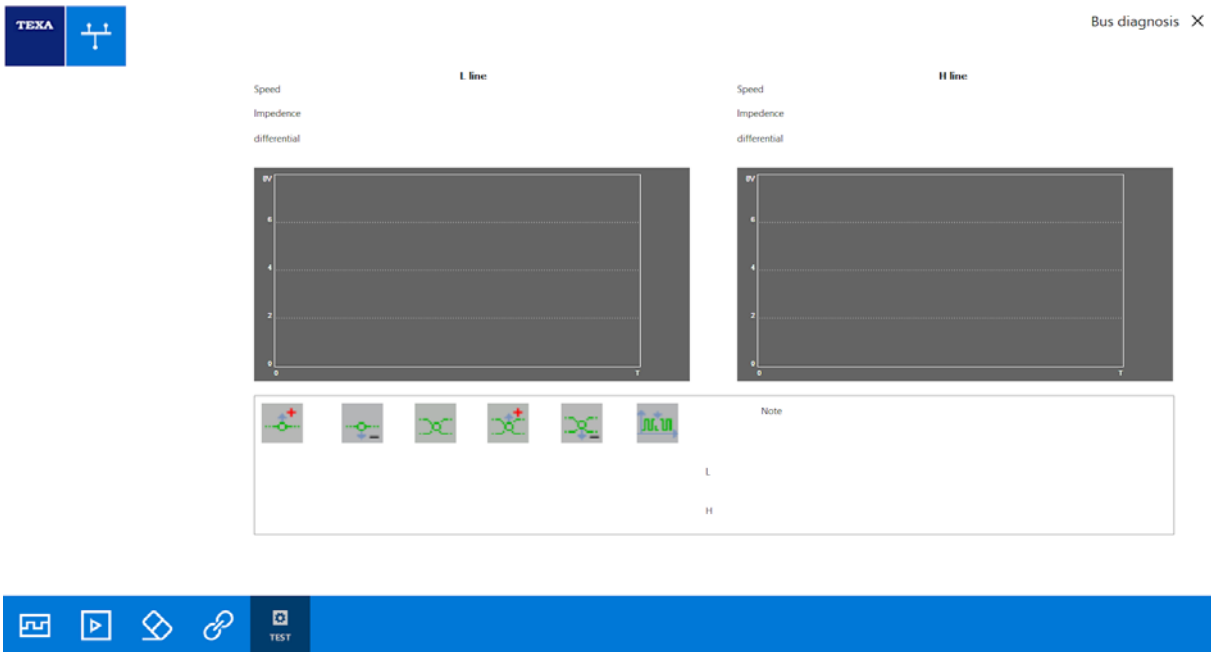

- *The presence of short circuits.*
- *The presence of cut-offs.*
- *The lack of termination resistance.*
- *Etc.*

Proceed as follows:

1. Press: 

The main screen of the function is displayed.



Icon	Name	Description
	BUS type	It allows selecting the type of BUS on which you intend to carry out the analysis.
	Start / Stop	It allows starting or stopping the analysis.
		
	Reset	It allows you to reset the parameters.
	Connections	It allows starting the video that illustrates how to connect the probes.
	Self-test	It allows you to carry out the self-test.

2. Press:



3. Select the type of BUS on which you intend to carry out the analysis.

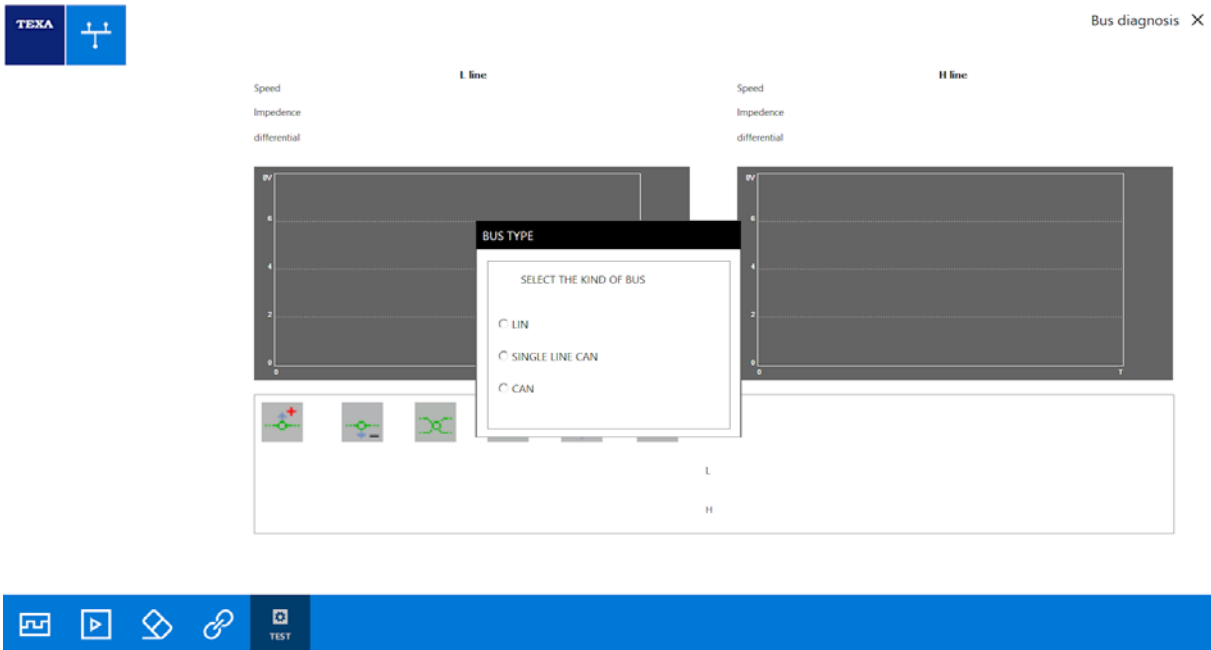

INFORMATION

This screen is displayed only if you did not select the type of BUS before starting the test.

4. Press:



5. Follow on screen instructions

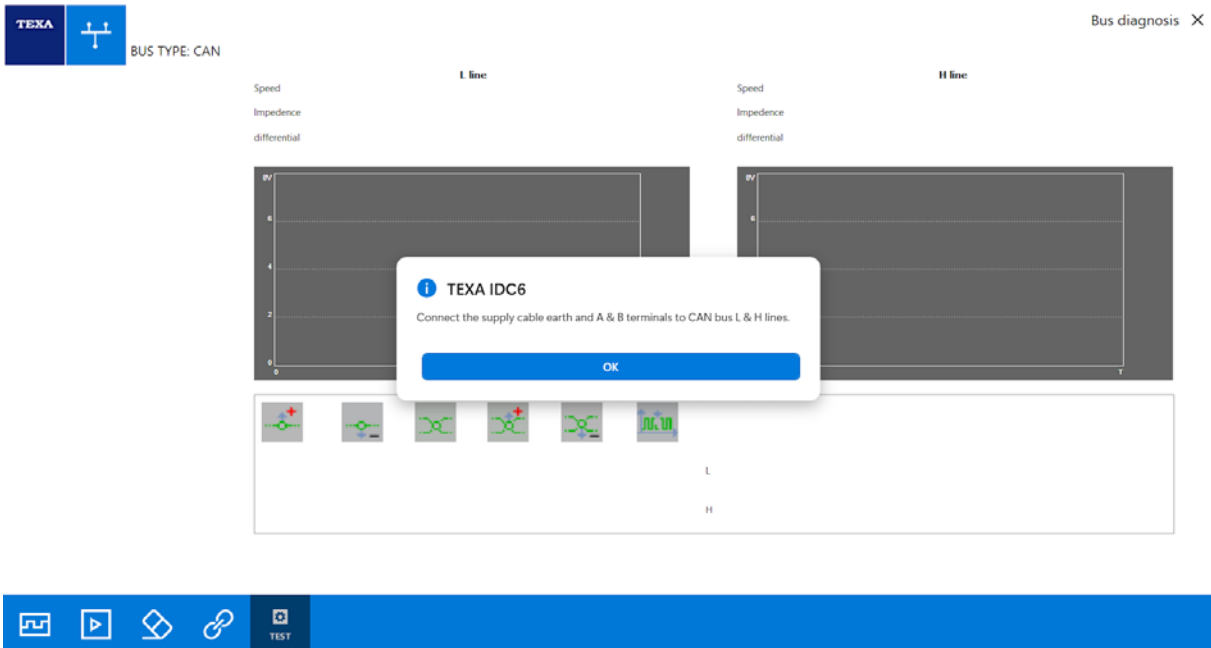

6. Press: **OK**

The analysis is started.

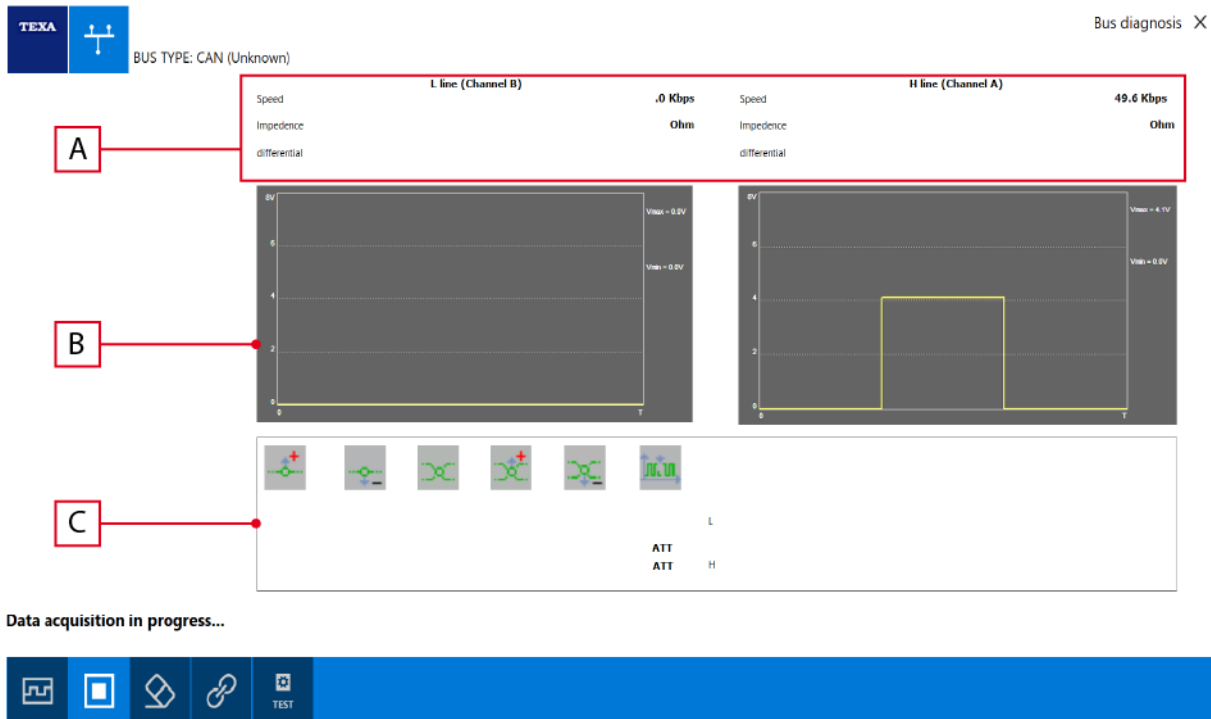

The following sections are available:

A) MEASUREMENTS

This section shows the acquired parameters:

Parameter	Unit of measurement
Transmission speed of L and H lines	kbit/s
Impedance of the L and H lines	Ohm
Differential of the L and H lines	Ohm

B) GRAPHS

This section provides a graphic representation of the voltage values in the **CAN L** and **CAN H** lines.

The maximum and minimum voltage values detected in the two lines are also provided.







INFORMATION

The software uses the colour green to indicate the waveforms that have a transmission speed greater than 100 kbit/s and the colour yellow for those that have a transmission speed below or equal to 100 kbit/s.

C)FAULTS

The table in this section indicates the type of error and the line (or lines) in which the error was detected.

The types of detectable errors are:



Icon	Error	Notes
	Short circuit to positive.	These errors can occur only on one line at a time.
	Short circuit to ground.	
	Cut-off.	
	Short circuit to positive of the L and H lines.	These errors occur on both lines simultaneously.
	Short circuit to ground of the L and H lines.	
	Short circuit of the L and H lines.	

The detected errors are marked by the abbreviations:

Abbreviation	Description
ATT	The detected error is currently present.
MEM	The error occurred but it is not present at the moment.

7. Press on the desired error.

The description of the error is displayed.



TIPO BUS: CAN (Sconosciuto)

Diagnosi BUS X

Linea L (Canale A)

Velocità .0 Kbps

Impedenza Ohm

Differenziale

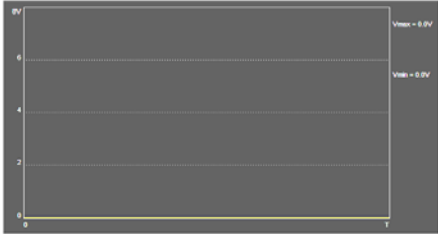



Linea H (Canale B)

Velocità 49.9 Kbps

Impedenza Ohm

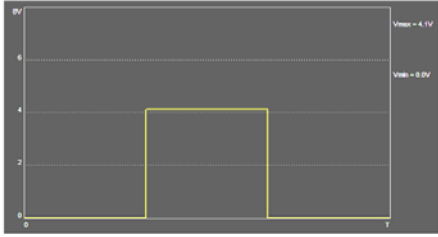
Differenziale







ATT















MEM

I H

E' stato rilevato un cortocircuito verso massa della linea L.
Anomalia presente



55 OSCILLOSCOPE









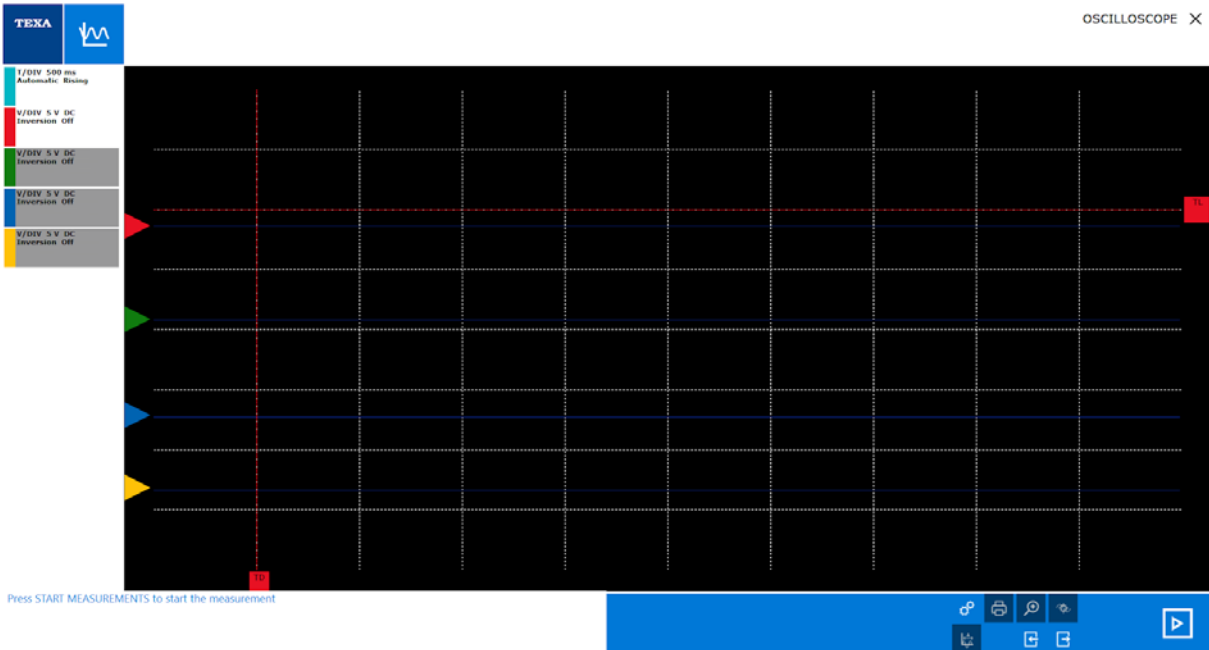

This function allows displaying graphically the trend of an electrical signal over time.

Proceed as follows:

1. Press: 

The main screen is displayed.



Icon	Name	Description
	Start / Stop	It allows starting or stopping the measurement.
		
	Settings	It allows accessing the oscilloscope settings.
	Print	It allows printing a report of the test that has been performed.
	Zoom	It allows zooming in an area on the graph.
	Cursors	It allows reading the signal value in the instant you are interested in.
	Autoscaling	It allows starting the autoscaling.
	Import	It allows importing the recording of a measurement performed and previously saved.



Save

It allows saving a measurement.

55.1 Starting/Stopping the Measurement

This function allows starting/stopping the measurement.

Proceed as follows:

1. Press: 

The measurement will begin.

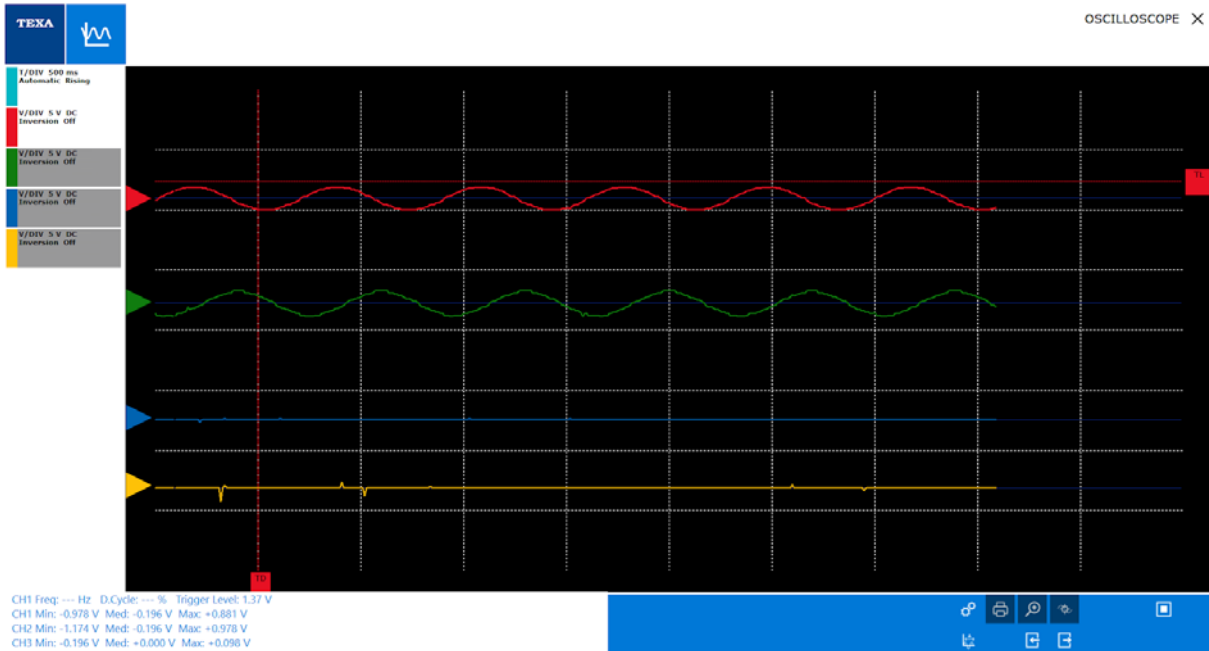

The software looks like an oscilloscope with 8 vertical divisions and 10 horizontal divisions.

You can measure a maximum of 4 signals corresponding to the 4 channels managed by the software.

INFORMATION

The number of channels may vary according to the device used.

SIDE MENU

The side menu includes:

- labels relating to the active channels (CH1...CH4);
- label relating to the Time Division (T/DIV).

The label related to a channel indicates its measurement scale (e.g. 1 V DC).

The grey labels indicate that the corresponding channels are not active.

Pressing on the side menu labels allows you to access the settings for the related channel.

INFORMATION

Through the T/DIV label you can also access the trigger settings.

LOWER BAR

The lower bar provides the following information related to the channels:

- **Min:** *indicates the minimum detected value.*
- **Med:** *indicates the medium detected value.*
- **Max:** *indicates the maximum detected value.*
- **Freq:** *Indicates the signal frequency. (*)*
- **D. Cycle:** *indicates the Duty Cycle value in percentage. (*)*

(*)Only for the trigger channel.

INFORMATION

The duty cycle has an actual value only when measuring a square wave.

To stop measuring, press:



55.1.1 T/DIV

This function allows setting the most appropriate Time Division for the measurement you wish to carry out.

Proceed as follows:

1. Press:T/DIV

The settings menu is displayed.

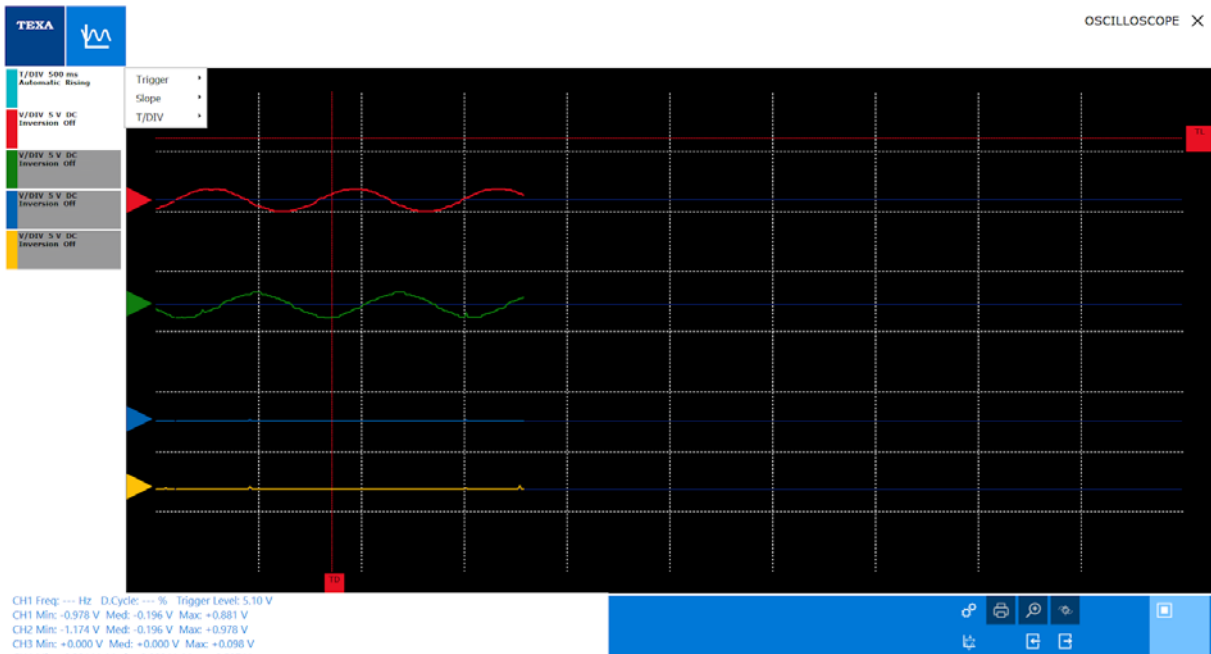

The following drop-down sub-menus are available:

Name	Description
Trigger	It allows setting the trigger as: <ul style="list-style-type: none"> • <i>Automatic</i> • <i>Normal</i> • <i>Single</i>
Slope	It allows setting the signal wavefront: <ul style="list-style-type: none"> • <i>Rising</i> • <i>Falling</i>
T/DIV	It allows setting the Time Division choosing its value within the range:500 ns ... 5 s

55.1.2 Channels

This function allows accessing the options of the selected channel.

Proceed as follows:

1. Press on the label of the desired channel.

The settings menu is displayed.

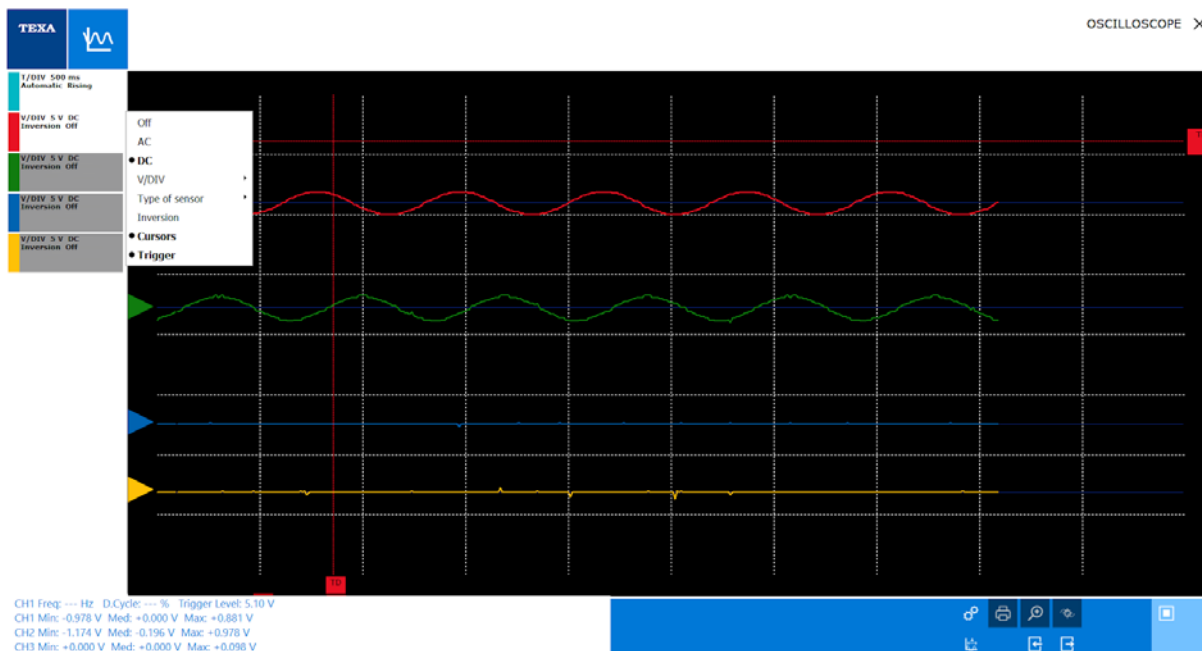

2. Select the desired option.

The options that can be selected in this screen are:

Option	Description
On / Off	It allows activating / deactivating the measurement of the selected channel.
AC	It allows setting the current type that is going to be measured in alternating current.
DC	It allows setting the current type that is going to be measured in direct current.
V/DIV - A/DIV	It allows displaying the drop-down menu through which you can change the voltage / current scale.
Type of sensor	It allows displaying the drop-down menu through which you can align the attenuation value of the oscilloscope to the one introduced by the probe and change the current scale.
Inversion	It allows inverting the signal waveform.
Cursors	It allows choosing on which channel to set the cursors.
Trigger	It allows choosing on which channel to set the trigger.

55.2 Autoscaling

This function allows carrying out the graph autoscale.

The function allows optimising the signal display.

Proceed as follows:

1. Press: 

Wait for the autoscale operation.

The autoscale has been carried out.



55.3 Zoom

This function allows zooming in an area on the graph.

INFORMATION

To launch this function, you must stop the measurement.

Proceed as follows:

1. Press: 
2. Press: 
3. Press on the screen and drag the pointer obliquely in order to create a selection area that includes the graph part you want to zoom in.
Zoom in carried out.



55.4 Cursors

It allows reading the signal value in the instant you are interested in.

INFORMATION

To launch this function, you must stop the measurement.

Proceed as follows:

1. Press: 
2. Press: 
3. Drag the labels “a” and “b” (the cursors) along the signal until reaching the desired points.

INFORMATION

Cursors are positioned on CH1 by default.

To position the cursors on another channel, click on the desired channel and tick Cursors.

The lower bar provides the following information:

Name	Description
Va / Aa	It shows the voltage/current value detected in the point indicated by the cursor “a”.
dV / dA	It indicates the difference between Va / Aa and Vb / Ab.
F	It indicates the signal frequency.
Vb / Ab	It shows the voltage/current value detected in the point indicated by the cursor “b”.
dT	It indicates the time interval between the point where the cursor “a” is positioned and the point where the cursor “b” is positioned.

55.5 Settings

This function allows accessing the oscilloscope settings.

Proceed as follows:

1. Press: 

The settings screen is displayed.

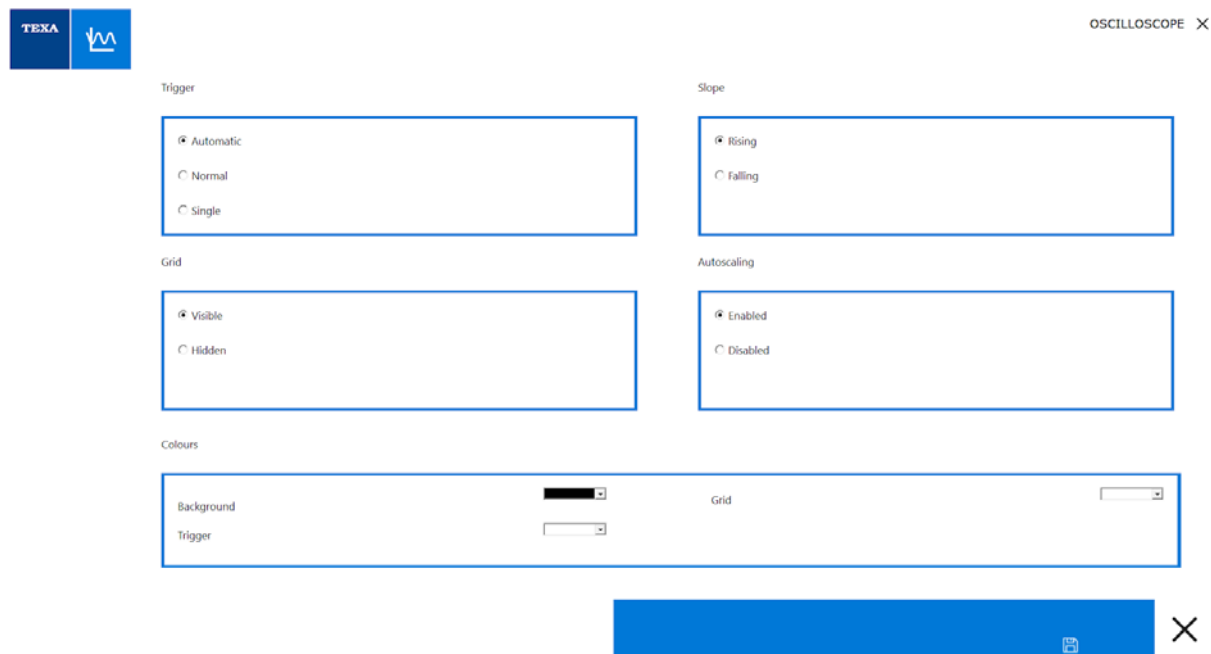

The options that can be selected in this screen are:

Name	Option	Description
Trigger	Automatic	The scan starts again automatically at the end of every scan also without a trigger event.
	Normal	The scan starts again only with a trigger event. At the end of the scan the trace is brought back to the initial point (on the left side of the screen) and waits for the following trigger event.
	Single	The software carries out 40 scans only with particular trigger events. At the end of the scans, you can check the sequence using the specific buttons.
Slope	Rising	It allows synchronising the trigger on the rising edge of the signal.
	Falling	It allows synchronising the trigger on the falling edge of the signal.
Grid	Visible	It allows showing the grid.
	Hidden	It allows hiding the grid.
Autoscaling	Amplitude	It allows enabling / disabling the autoscale. If this option is not ticked the software informs you when the signal is out of range.
Colours	Background	It allows selecting the background colour.
	Grid	It allows selecting the grid colour.

2. Carry out the desired settings.

3. Press: 

56 MULTIMETER









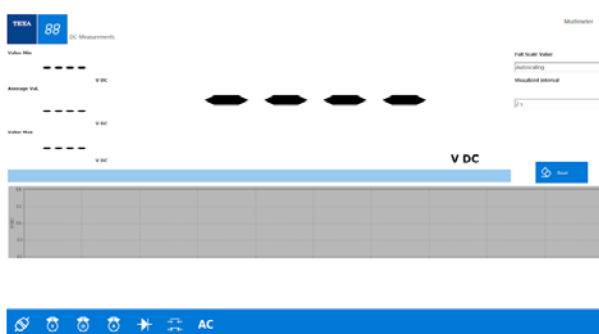

This function allows to carry out voltage measurements, current, diode test and short-circuit search.



Proceed as follows:

1. Press .
The main screen of **Multimeter** is displayed.

2. Press .



Icon	Name	Description
	Connect / Disconnect	It allows you to connect the software to the device and start the measurement.
		
	Voltmeter	Allows to carry out voltage measurements.
	Ohmmeter	Allows to carry out resistance measurements.
	Ammeter	Allows to carry out current measurements.
	Diode Test	Allows to verify the diodes bias. If the diode is directly polarised the software supplies the diode polarisation voltage. If the diode is inversely polarised the software indicates OVL (overload).
	Short Circuit Check	Allows to verify the presence of a short-circuit. The software indicates the absence of a short-circuit indicating OVL (overload) whereas when short-circuit is present it indicates the resistance value.

	AC / DC	Allows to set the current type that is going to be measured (alternate or direct).
		The type of current can only be changed from the Voltmeter and Ammeter functions.
	Reset	Allows you to clear the graph.

56.1 Voltmeter

This function allows to carry out voltage measurements.

Proceed as follows:

1. Press .

The screen of the voltmeter is displayed.

2. Press .

The measuring process has been started.

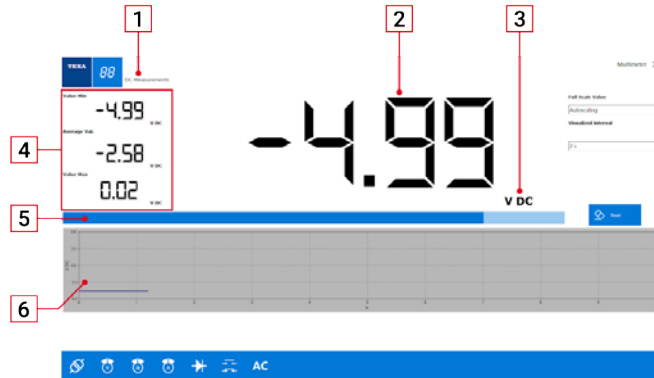

The screen provides the following information:

1. indicator of the type of current;
2. instantaneous voltage detected;
3. indicator of the unit of measurement and type of current;
4. voltage indicators:
 - minimum voltage detected;
 - average voltage detected;
 - maximum voltage detected;
5. scale level indicator *;
6. graph of the voltage detected over time.

(*) This bar is useful to prevent the measurement from going out of range.

Using the drop-down menus on the right side of the screen you can change the **Full Scale** and **Interval Displayed**.

Items available in the **Full Scale** menu:

- ± 6 V scale.
- ± 60 V scale.
- ± 400 V scale.
- *Autoscaling*.

In **Autoscaling** mode the software automatically sets the most proper scale between those available.

The items available in the **Interval Displayed** menu cover the range between 0.25 s and 10000 s.

3. To disconnect the tool press .

56.2 Ohmmeter

This function allows to carry out resistance measurements.

Proceed as follows:

1. Press .

The screen of the ohmmeter is displayed.

2. Press .

The measuring process has been started.

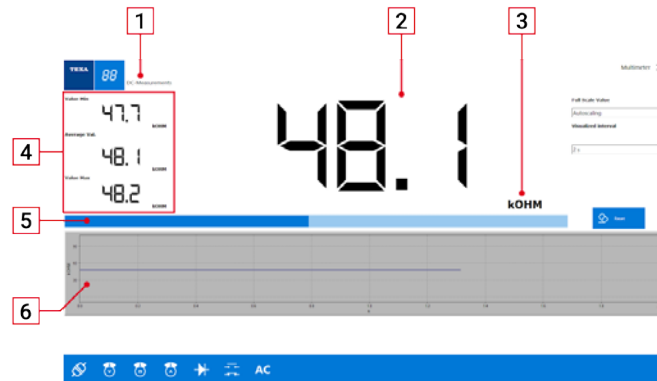

The screen provides the following information:

1. indicator of the type of current;
2. instant resistance detected;
3. indicator of the unit of measurement and type of current;
4. resistance indicators:
 - minimum resistance detected;
 - medium resistance detected;
 - maximum resistance detected;
5. scale level indicator *;
6. graph of the resistance detected over time.

(*) This bar is useful to prevent the measurement from going out of range.

Using the drop-down menus on the right side of the screen you can change the **Full Scale** and **Interval Displayed**.

Items available in the **Full Scale** menu:

- *Scale from 0 to 1 k Ω .*
- *Scale from 0 to 100 k Ω .*
- *Scale from 0 to 10 M Ω .*
- *Autoscaling.*

In **Autoscaling** mode the software automatically sets the most proper scale between those available.

The items available in the **Interval Displayed** menu cover the range between 0.25 s and 10000 s.

3. To disconnect the tool press .

56.3 Ammeter

This function allows to carry out current measurements.

Proceed as follows:

1. Press .

The screen of the ammeter is displayed.

2. Press .

The measuring process has been started.

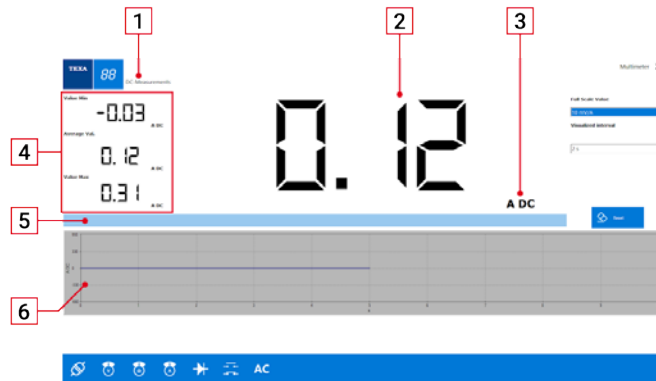

The screen provides the following information:

1. indicator of the type of current;
2. instant current detected;
3. indicator of the unit of measurement and type of current;
4. detected currents:
 - minimum current detected.
 - medium current detected;
 - maximum current detected;
5. scale level indicator *;
6. graph of the current detected over time.

(*) This bar is useful to prevent the measurement from going out of range.

Using the drop-down menus on the right side of the screen you can change the **Full Scale** and **Interval Displayed**.

Items available in the **Full Scale** menu:

- *Sensitivity at 1 mV/A (measurement range ± 120 A).*
- *Sensitivity at 10 mV/A (measurement range ± 440 A).*
- *Sensitivity at 0.1 V/A (measurement range ± 35 A).*
- *Sensitivity at 1 V/A (measurement range ± 3.5 A).*
- *Autoscaling.*

In **Autoscaling** mode the software automatically sets the most proper scale between those available.

NOTICE

Set the same sensitivity both in the software and in the amperometric clamp.

For example: if the sensitivity in the software is set to 1 mV/A, the same sensitivity has to be set also in the amperometric clamp.

The items available in the **Interval Displayed** menu cover the range between 0.25 s and 10000 s.

3. To disconnect the tool press .

56.4 Diode Test

This function allows verifying the diode polarisation.

Proceed as follows:

1. Press .

The screen of the diode polarization test is displayed.

2. Press .

The measuring process has been started.

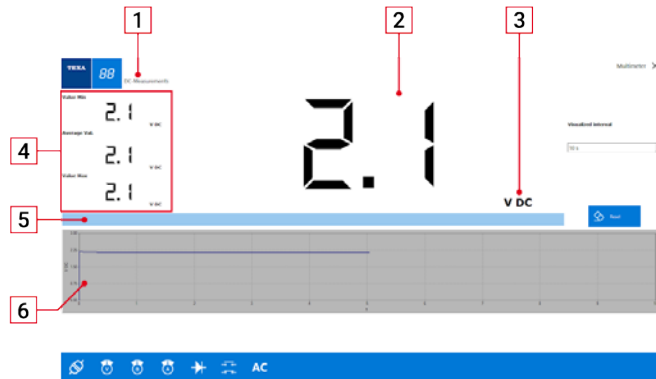

The screen provides the following information:

1. *indicator of the type of current;*
2. *diode polarisation voltage.*
3. *indicator of the unit of measurement and type of current;*
4. *voltage indicators:*
 - *minimum voltage detected;*
 - *average voltage detected;*
 - *maximum voltage detected;*
5. *scale level indicator *;*
6. *graph of the voltage detected over time.*

(*) This bar is useful to prevent the measurement from going out of range.

If the diode is directly polarised the software supplies the diode polarisation voltage.

If the diode is inversely polarised the software indicates OVL (overload).

3. To disconnect the tool press .

56.5 Short Circuit Check

This function allows checking for possible short circuits.

Proceed as follows:

1. Press .

The screen of short-circuits search is displayed.

2. Press .

The measuring process has been started.



The screen provides the following information:

1. *indicator of the type of current;*
2. *instant resistance detected;*
3. *measurement unit indicator;*
4. *resistance indicators:*
 - *minimum resistance detected;*
 - *medium resistance detected;*
 - *maximum resistance detected;*
5. *scale level indicator *;*
6. *graph of the voltage detected over time.*

(*) This bar is useful to prevent the measurement from going out of range.

The software indicates the absence of a short-circuit indicating OVL (overload) whereas when short-circuit is present it indicates the resistance value.

3. To disconnect the tool press .

57 CHARGE START



This function allows you to verify the efficiency of the electrical components involved in the engine ignition phase (starter motor) and of the battery charging (alternator) and the efficiency of the battery itself.

INFORMATION

This function is not compatible with 24 V power supply systems.

The function allows you to carry out the following tests:

- *Battery Test.*
- *System Charge.*
 - *Charge Efficiency.*
 - *Charge Cable.*
 - *Ripple Output ALT+.*
 - *Ripple Output D+.*
- *Start System.*
 - *Start Test.*
 - *Engine Ground Test.*
 - *Starter Motor + Test.*

Proceed as follows:





1. Press: 

The test selection screen is displayed.



WINBATTERY PROBE X



Icons	Name	Description
	Battery Test	It allows you to verify the efficiency status of the battery.
	System Charge	It allows you to verify the alternator's operation through voltage and current tests.
	Start System	It allows you to verify the operation of the engine ignition system through voltage and current tests.
	Result Summary	It allows you to view, store and print the results of the performed tests.

57.1 Battery Test

This function allows you to verify the efficiency status of the battery.

In order to carry out this test, you need the following material:

- *Device.*
- *BPP Cable.*

INFORMATION

Before launching the test, we recommend letting the battery rest for at least 6 hours.





The test results could be unreliable if the battery is too low.

Proceed as follows:

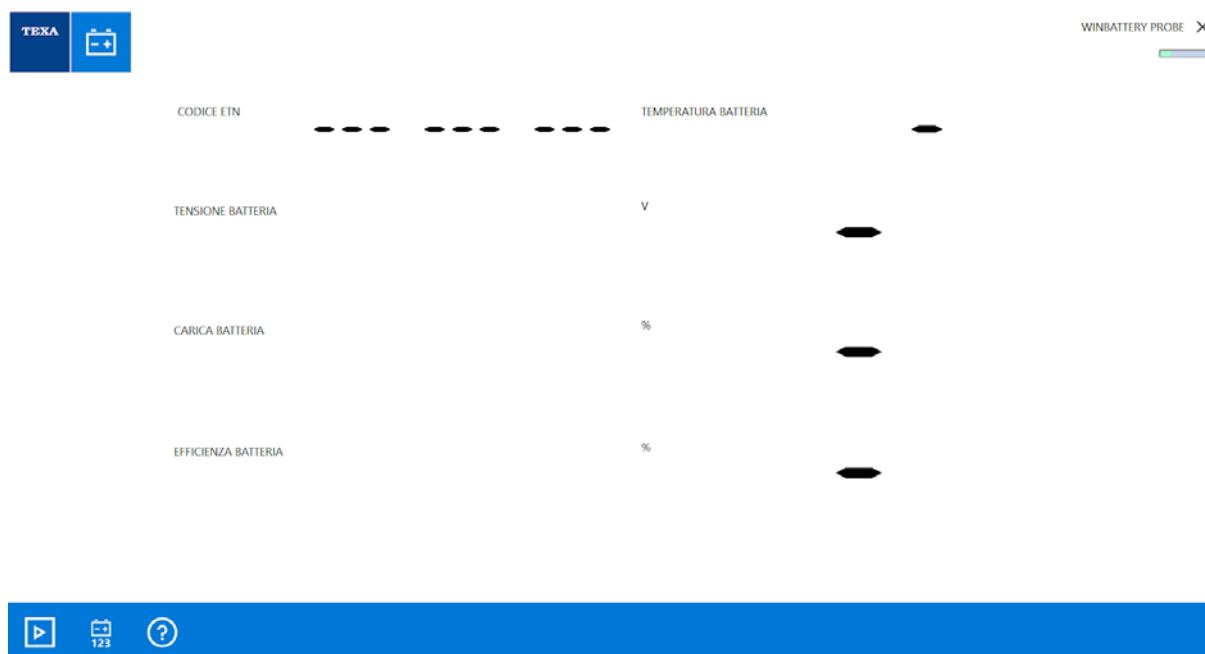
1. Press: 

The initial test screen is displayed.



Icons	Name	Description
	Start / Stop	It allows starting/stopping the test.
		
	Change Battery Values	It allows you to change the data regarding the features of the battery with respect to the previous test.
	Cable Connection	It allows you to launch a video regarding the connections that must be done.

2. Press: 

3. Connect the wirings to the tool and to the vehicle as illustrated in the video.

4. Press: 

5. Enter the required data.



WINBATTERY PROBE X

TEMPERATURA BATTERIA	°C	+20
CORRENTE DI SPUNTO teorica	A	200
CODICE ETN		



INFORMATION

The data that is required is generally printed on the sticker located on the battery.

ETN is the acronym for European Type Number, a 9 digit code that indicates the electrical features and the dimensions of the battery.

For example, the structure of ETN 543 110 033 is the following:

- 543 group A.
- 110 group B.
- 033 group C.

Group A indicates the battery's capacity and voltage.

- All the numbers above 500 indicate 12 V power supply batteries.
- All the numbers below 500 indicate 6 V power supply batteries.

In order to learn the battery's capacity, you must subtract 500 from the number in group A: $543-500=43$, therefore 43 Ah.

Group B represents the geometrical features of the battery, other than indicating its polarity, the type of terminal, etc.

Group C, multiplied by 10, indicates the starting current according to the EN regulations: $033 \times 10 = 330$, therefore 330 A EN.

6. Press:



7. Press:



8. The software asks if the battery has been at rest for at least 6 hours.

If it has been, press: 

If not, press: 

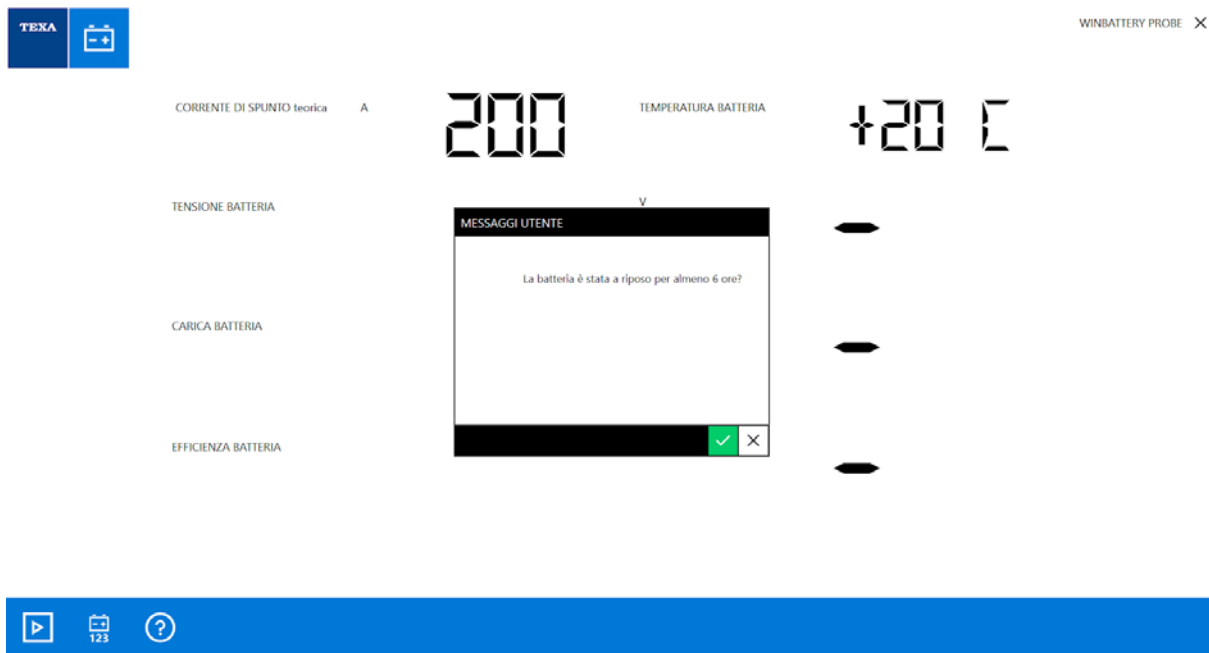

9. Follow the instructions that appear on screen.

INFORMATION

The supplied instructions vary based on the status of the battery.

10. Wait for the result of the test.

The test result is displayed.

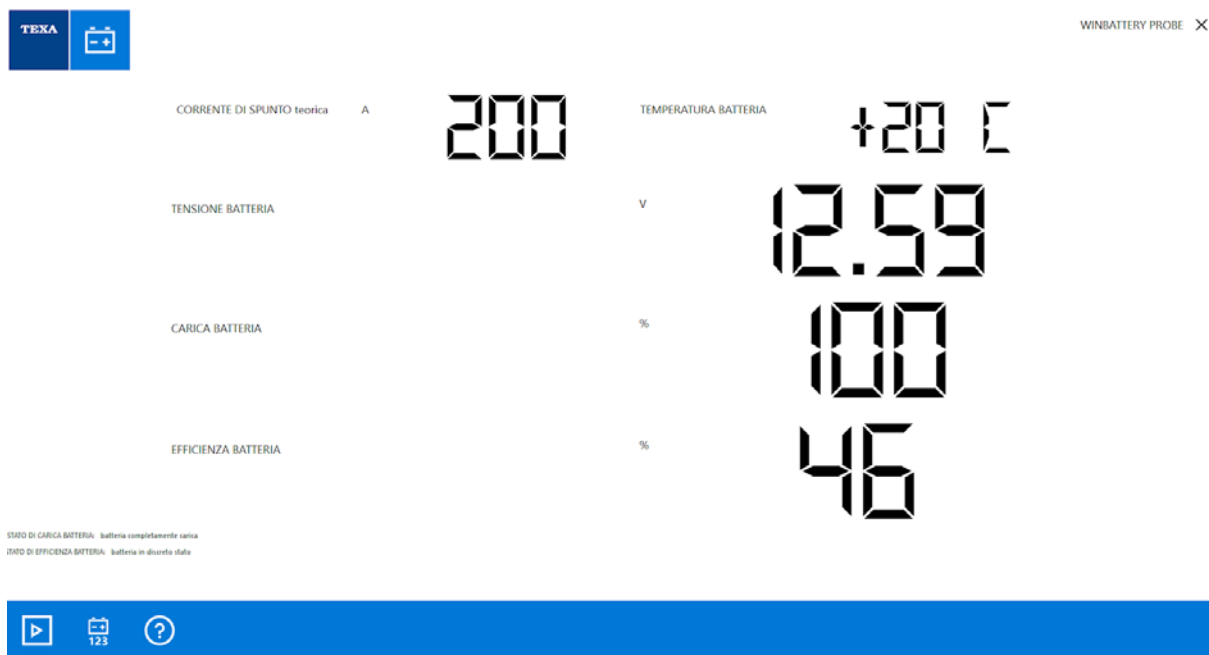

The screen provides the following information:

- *Theoretical pickup current (previously entered by the user).*

- *Battery temperature (previously entered by the user).*
- *Detected battery voltage.*
- *Battery charge.*
- *Battery efficiency.*
- *Battery state of charge.*
- *Battery efficiency status.*

57.2 System Charge

This function allows you to verify the alternator's operation through voltage and current tests. Proceed as follows:





1. Press: 

The initial test screen is displayed.



WINBATTERY PROBE X



Icons	Name	Description
	Charge Efficiency	It allows you to launch the efficiency test of the battery's charging system.
	Charge Cable	It allows you to launch the operation test of the connection cable from alternator's B+ to the battery's positive.
	Ripple Output ALT+	It allows you to launch the operation test of the diode bridge used to rectify the current generated by the alternator (alternator's B+ output).
	Ripple Output D+	It allows you to launch the operation test of the diode bridge of alternator's output D+ in order to verify the correct management of the charging warning light of the alternator itself.

57.2.1 Charge Efficiency

This function allows you to launch the efficiency test of the battery's charging system.

In order to carry out these tests, you need the following material:



- *Device.*
- *BPP Cable.*
- *BICOR amperometric clamp.*

Proceed as follows:

1. Press: 

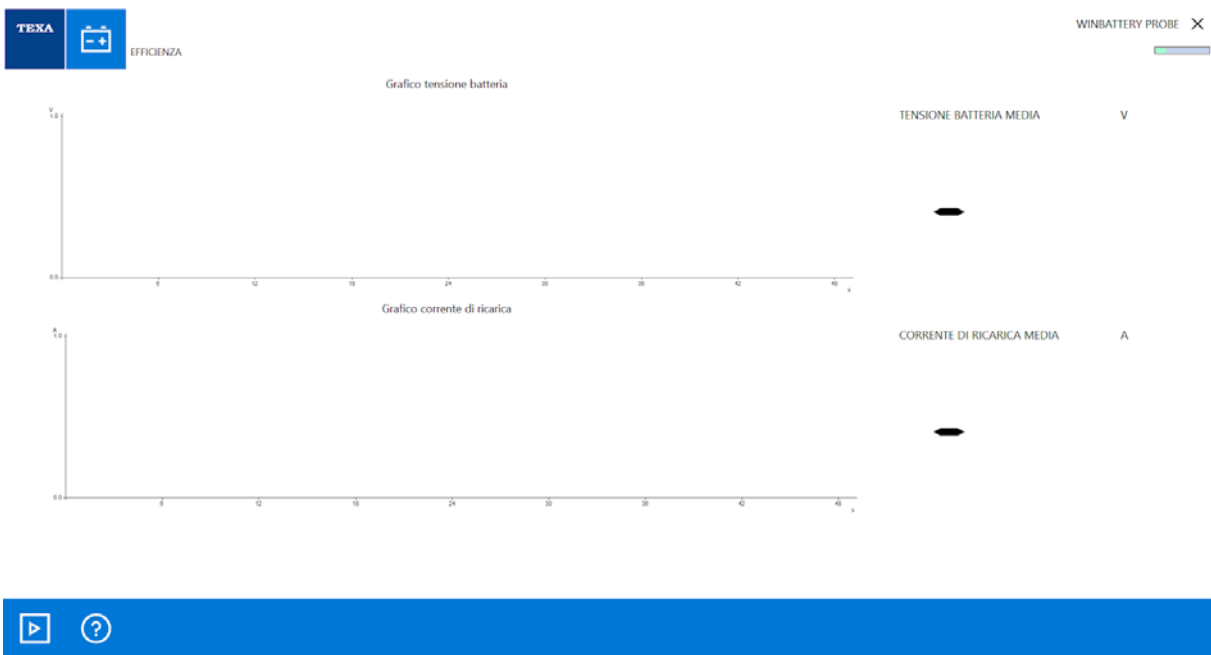
The main test screen is displayed.



Icons	Name	Description
	Start / Stop	It allows starting/stopping the test.
		
	Cable Connection	It allows you to launch a video regarding the connections that must be done.

2. Press: 

3. Connect the wirings to the tool and to the vehicle as illustrated in the video.

4. Select the ammeter scale.



WINBATTERY PROBE X

Scala della pinza amperometrica

 1 mV/A

 10 mV/A

 100 mV/A

 1 V/A

5. Press:



6. Follow the instructions that appear on screen.



EFFICIENZA

WINBATTERY PROBE X

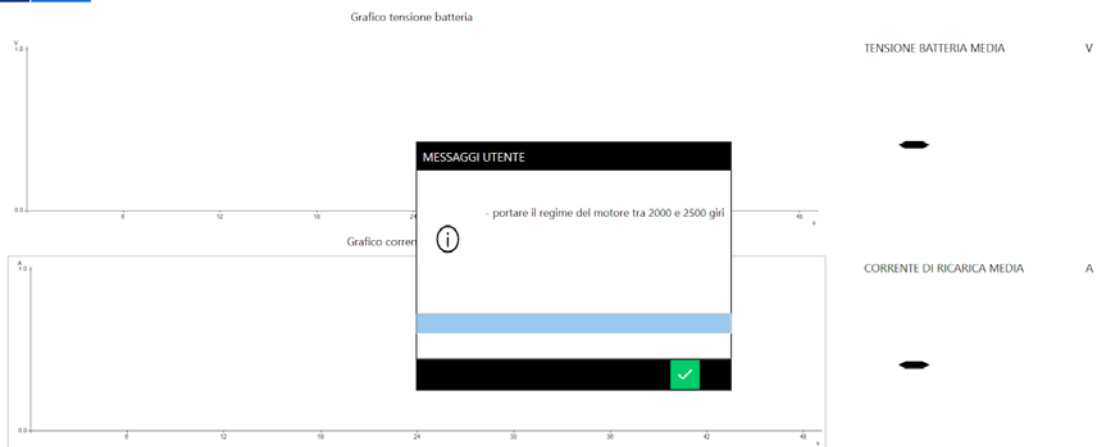

7. Press:



8. Wait for the result of the test.

The test result is displayed.



The screen provides the following information:

- *Battery voltage graph.*
- *Charge current graph.*
- *Average battery voltage.*
- *Average charge current.*
- *Test result.*

57.2.2 Charge Cable

This function allows you to launch the operation test of the connection cable from alternator's B+ to the battery's positive.

In order to carry out this test, you need the following material:



- *Device.*
- *BPP Cable.*
- *+ALT Cable.*

Proceed as follows:

1. Press: 

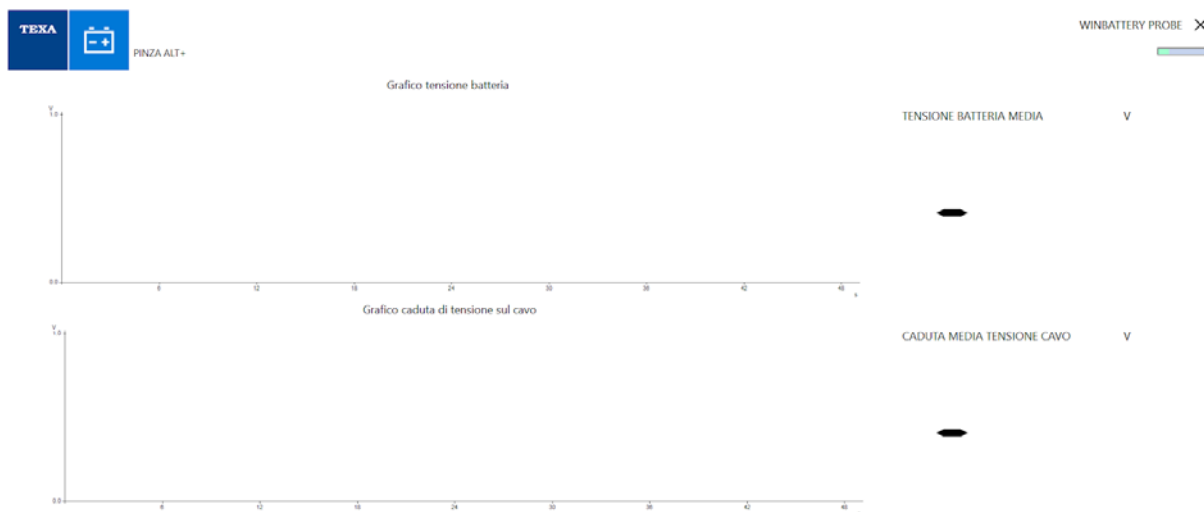
The main test screen is displayed.



Icons	Name	Description
	Start / Stop	It allows starting/stopping the test.
		
	Cable Connection	It allows you to launch a video regarding the connections that must be done.

2. Press: 

3. Connect the wirings to the tool and to the vehicle as illustrated in the video.

4. Follow the instructions that appear on screen.

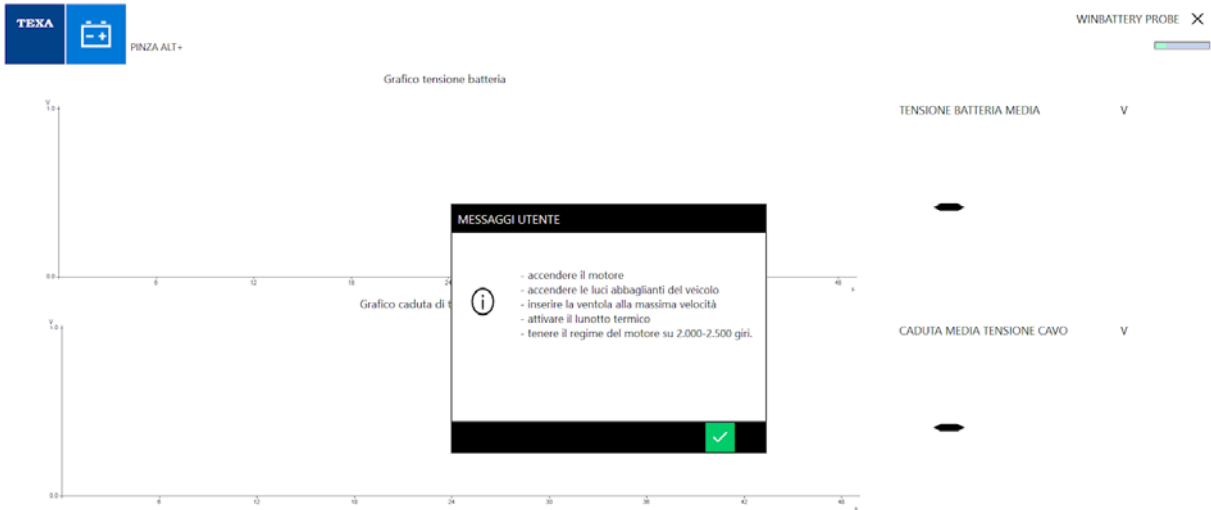

5. Press:



6. Wait for the result of the test.

The test result is displayed.

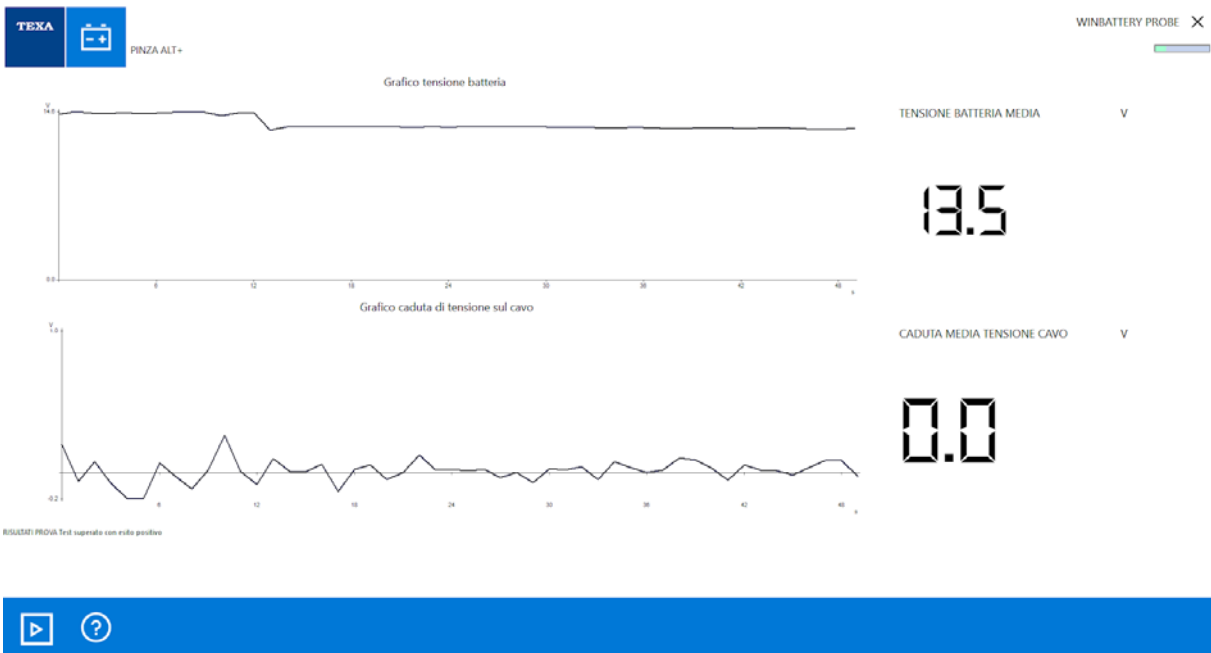

The screen provides the following information:

- *Battery voltage graph.*
- *Voltage drop on cable graph.*
- *Average battery voltage.*
- *Charge voltage average drop.*
- *Test result.*

57.2.3 Ripple Output ALT+

This function allows you to launch the operation test of the diode bridge used to rectify the current generated by the alternator (alternator's B+ output).

In order to carry out this test, you need the following material:



- *Device.*
- *BPP Cable.*
- *+ALT Cable.*

Proceed as follows:

1. Press: 

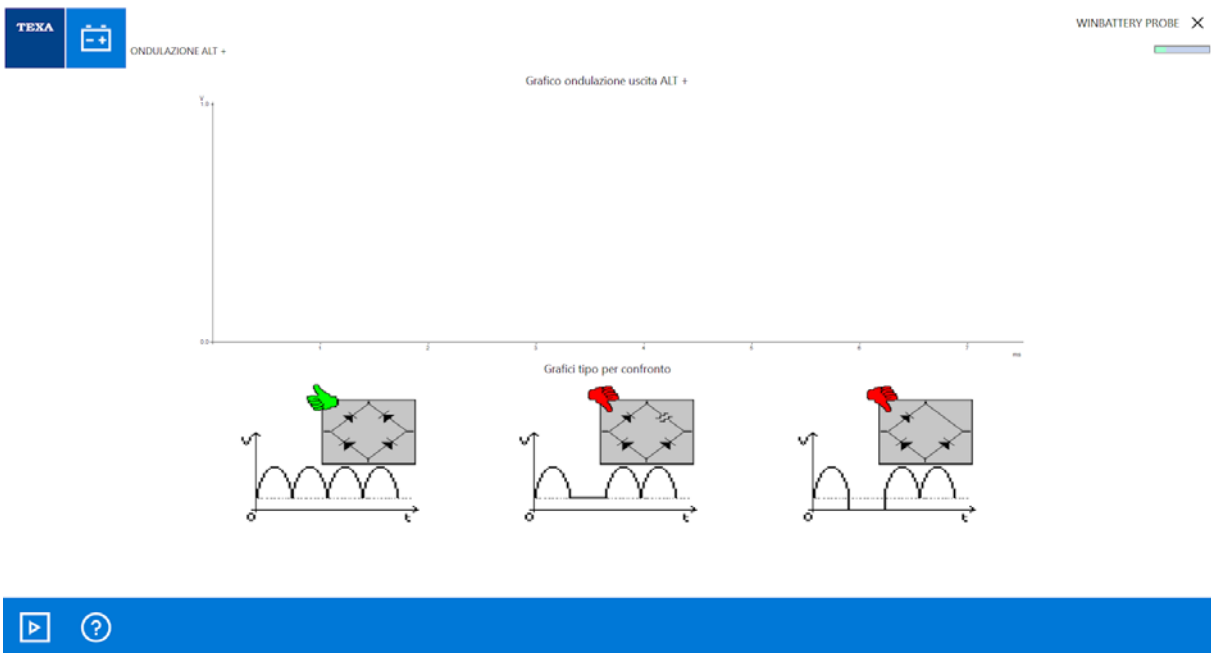
The main test screen is displayed.



Icons	Name	Description
	Start / Stop	It allows starting/stopping the test.
		
	Cable Connection	It allows you to launch a video regarding the connections that must be done.

2. Press: 

3. Connect the wirings to the tool and to the vehicle as illustrated in the video.

4. Follow the instructions that appear on screen.

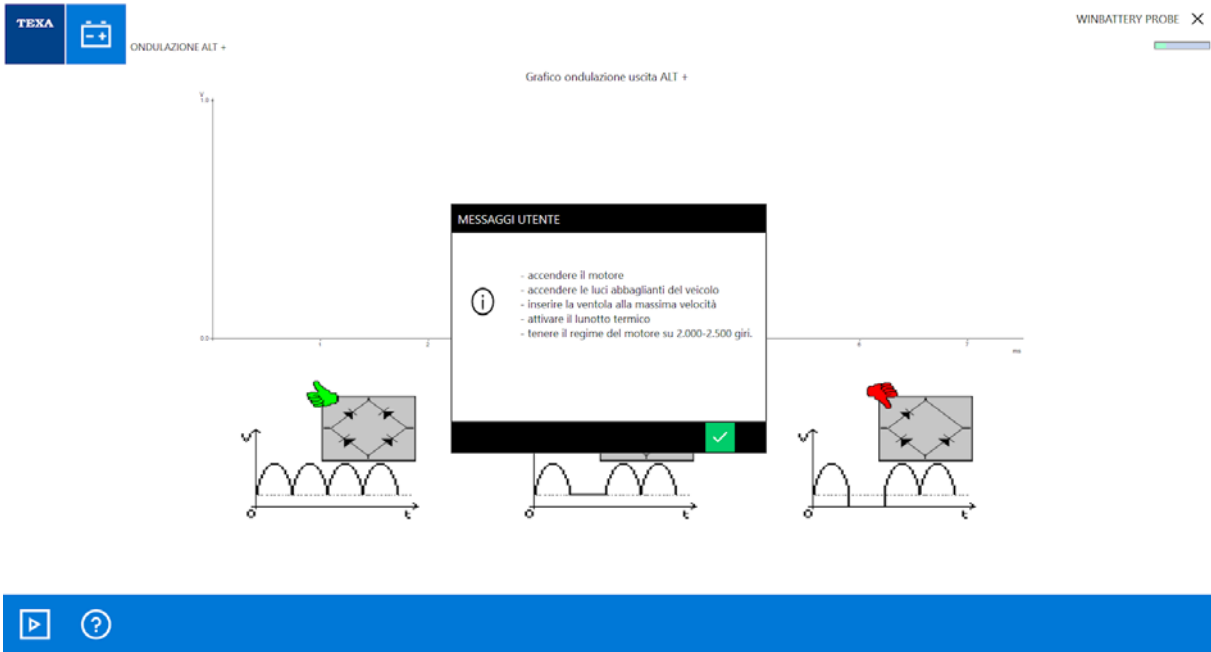

5. Press: 

6. Wait for the result of the test.

The test result is displayed.

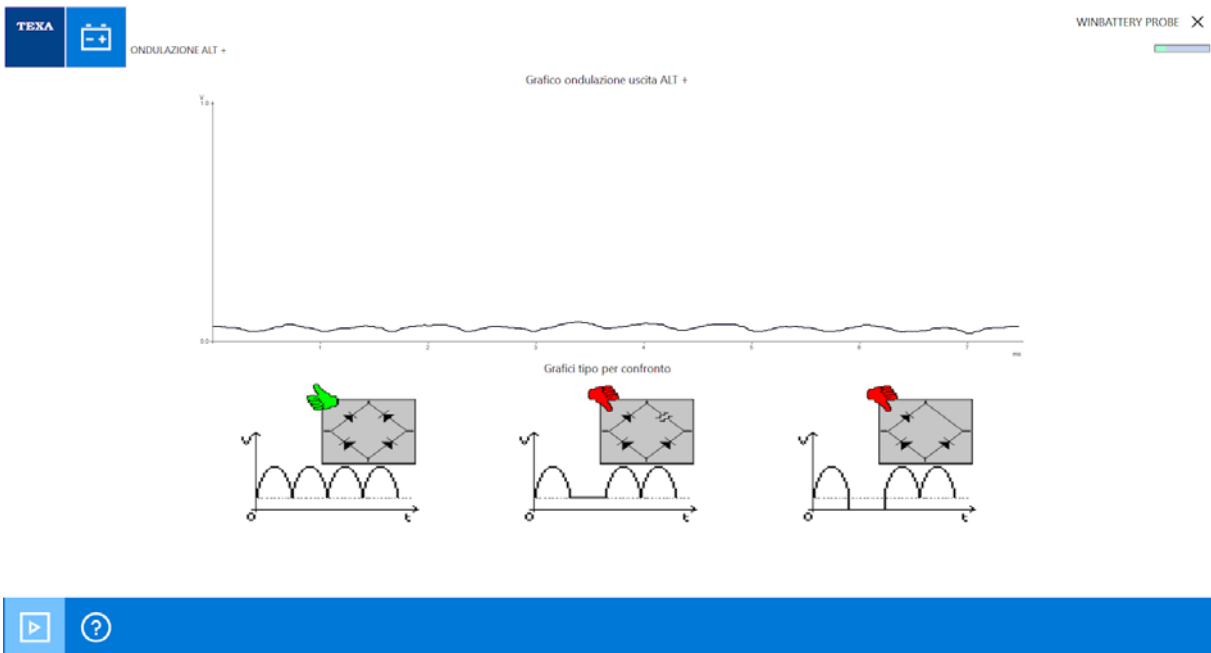

The screen provides the following information:

- *Ripple output ALT+ graph.*
- *Type graph for comparison.*

57.2.4 Ripple Output D+

This function you to launch the operation test of the diode bridge of alternator's output D+ in order to verify the correct management of the charging warning light of the alternator itself.

In order to carry out this test, you need the following material:



- *Device.*
- *BPP Cable.*
- *+D Cable.*

Proceed as follows:

1. Press: 

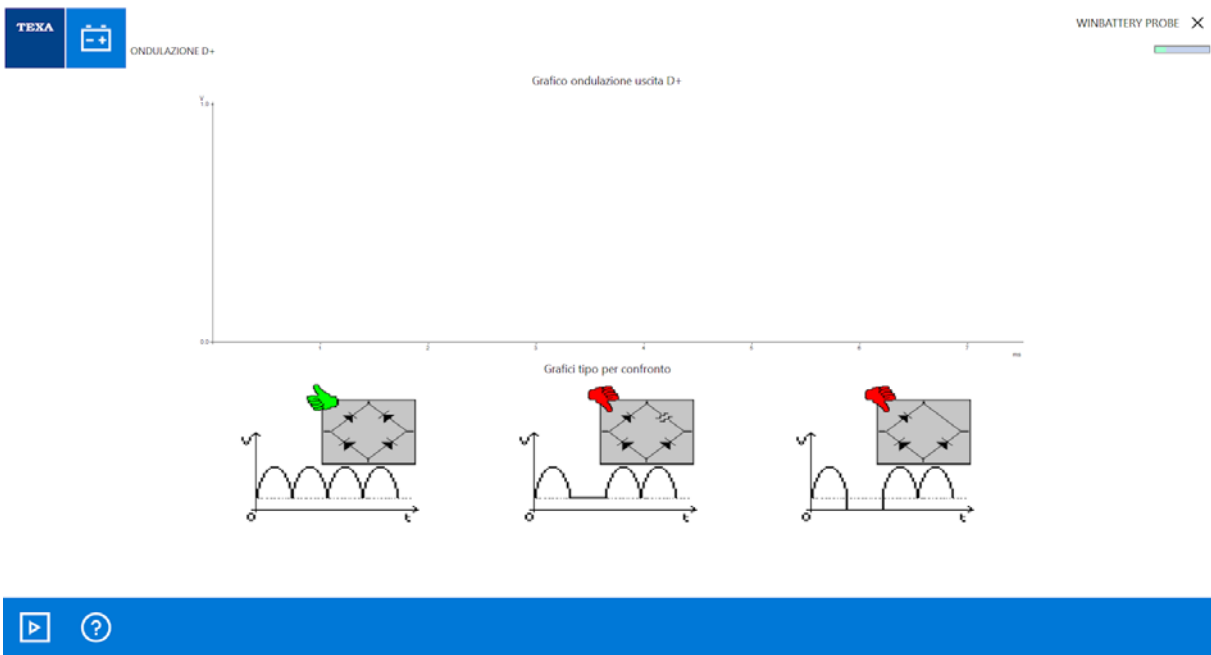
The main test screen is displayed.



Icons	Name	Description
	Start / Stop	It allows starting/stopping the test.
		
	Cable Connection	It allows you to launch a video regarding the connections that must be done.

2. Press: 

3. Connect the wirings to the tool and to the vehicle as illustrated in the video.

4. Follow the instructions that appear on screen.

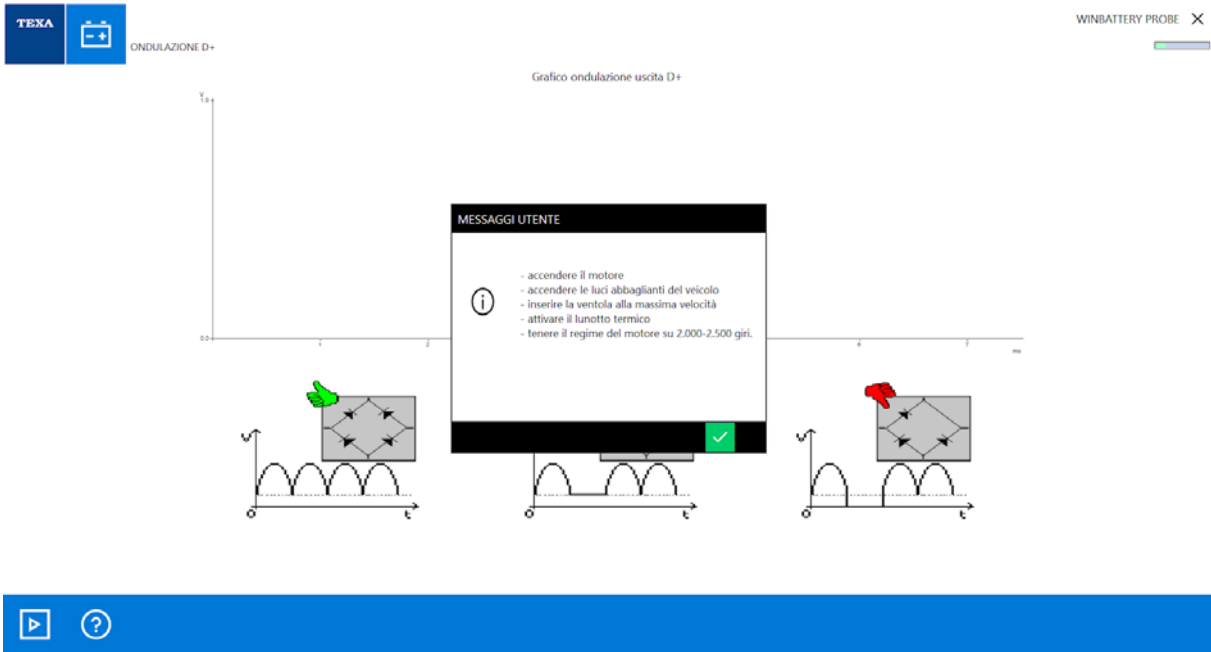

5. Press:



6. Wait for the result of the test.

The test result is displayed.

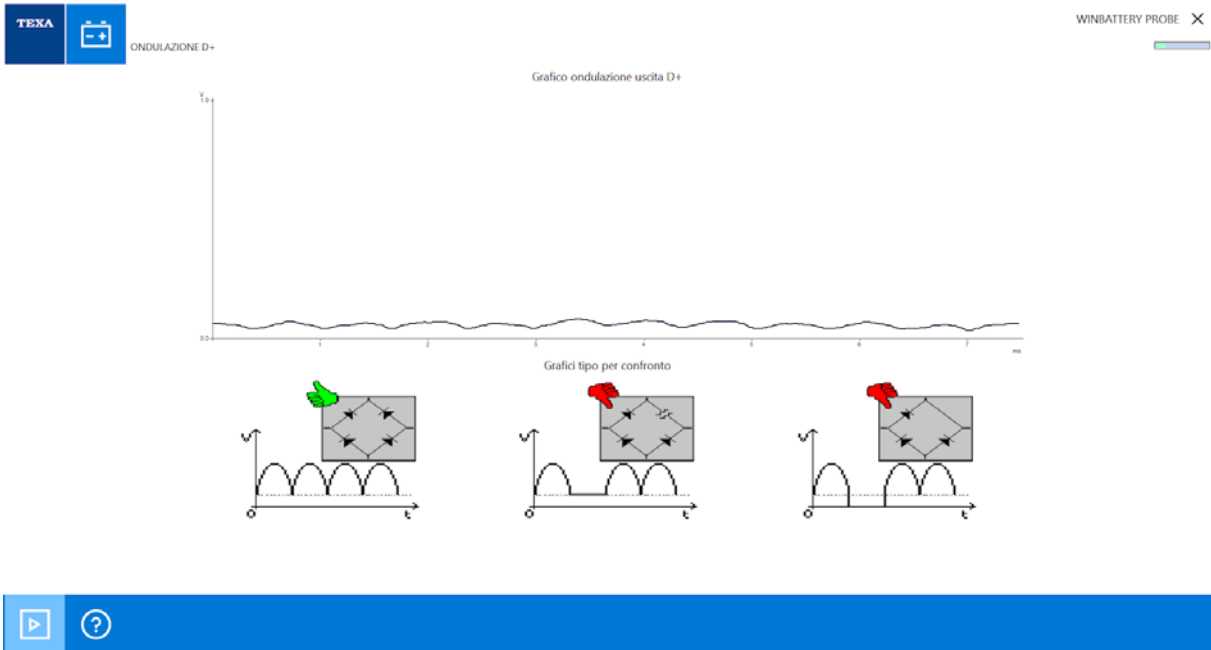

The screen provides the following information:

- *Ripple output D+ graph.*
- *Type graph for comparison.*

57.3 Start System

This function allows you to verify the operation of the engine ignition system through voltage and current tests.

Proceed as follows:



1. Press: 

The initial test screen is displayed.



WINBATTERY PROBE X



Icons	Name	Description
	Start Test	It allows you to check the voltage and current values during the vehicle ignition phase.
	Engine Ground Test	It allows you to check the voltage value at the ends of the engine's ground cable.
	Starter Motor + Test	It allows you to check the voltage value of the battery and of the positive cable of the vehicle's starter motor.

57.3.1 Start Test

This function allows you to check the voltage and current values during the vehicle ignition phase. In order to carry out this test, you need the following material:





- Device.
- BPP Cable.
- BICOR amperometric clamp.

Proceed as follows:

1. Press: 

The initial test screen is displayed.



Icons	Name	Description
	Start / Stop	It allows starting/stopping the test.
		
	Change Battery Values	It allows you to change the data regarding the features of the battery with respect to the previous test.
	Cable Connection	It allows you to launch a video regarding the connections that must be done.

2. Press: 

3. Connect the wirings to the tool and to the vehicle as illustrated in the video.

4. Press: 

5. Enter the required data.

TEXA  WINBATTERY PROBE X

TEMPERATURA BATTERIA °C +20

CORRENTE DI SPUNTO teorica A 400

CODICE ETN

Scala della pinza amperometrica 1 mV/A 10 mV/A 100 mV/A 1 V/A



6. Press:



7. Press:



8. Follow the instructions that appear on screen.

TEXA  TEST AVVIAMENTO WINBATTERY PROBE X

CORRENTE DI SPUNTO teorica A 150

TEMPERATURA BATTERIA +20 °C

Grafico tensione batteria

TENSIONE BATTERIA MEDIA V

CORRENTE DI SPUNTO MEDIA A

MESSAGGI UTENTE

Avviare e attendere...

Attenzione: il verso della freccia deve essere uscente dalla batteria se la pinza è collegata al cavo negativo della batteria, mentre deve essere entrante se collegata al cavo positivo.

9. Wait for the result of the test.

The test result is displayed.

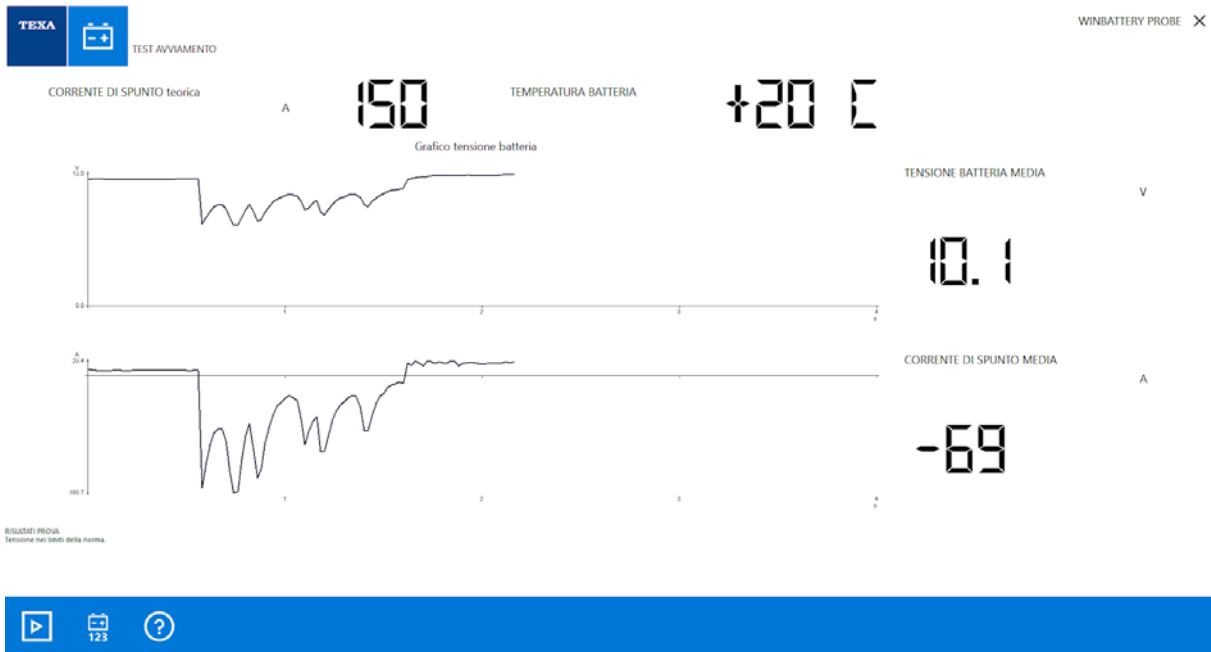

- *Theoretical pickup current (previously entered by the user).*
- *Battery temperature (previously entered by the user).*
- *Battery voltage graph.*
- *Charge current graph.*
- *Average battery voltage.*
- *Average charge current.*
- *Test result.*

57.3.2 Engine Ground Test

This functions you to check the voltage value at the ends of the engine's ground cable.

In order to carry out this test, you need the following material:



- *Device.*
- *BPP Cable.*
- *-MOT Cable.*
- *BICOR amperometric clamp.*

Proceed as follows:

1. Press: 

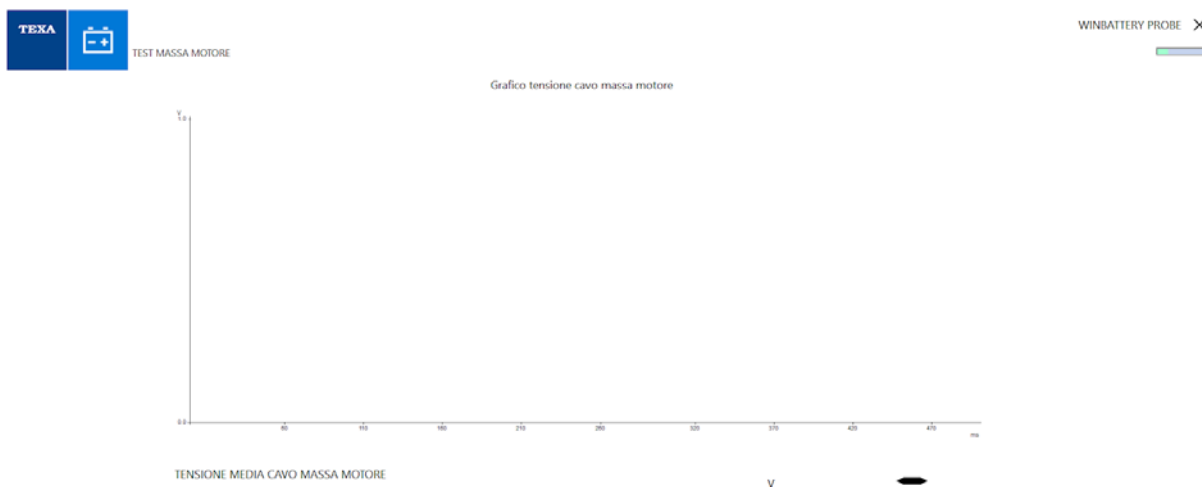
The main test screen is displayed.



Icons	Name	Description
	Start / Stop	It allows starting/stopping the test.
		
	Cable Connection	It allows you to launch a video regarding the connections that must be done.

2. Press: 

3. Connect the wirings to the tool and to the vehicle as illustrated in the video.

2. Press: 

4. Select the ammeter scale.



WINBATTERY PROBE X

Scala della pinza amperometrica

1 mV/A

10 mV/A

100 mV/A

1 V/A



6. Press:



4. Follow the instructions that appear on screen.



TEST MASSA MOTORE

WINBATTERY PROBE X

Grafico tensione cavo massa motore



6. Wait for the result of the test.

The test result is displayed.

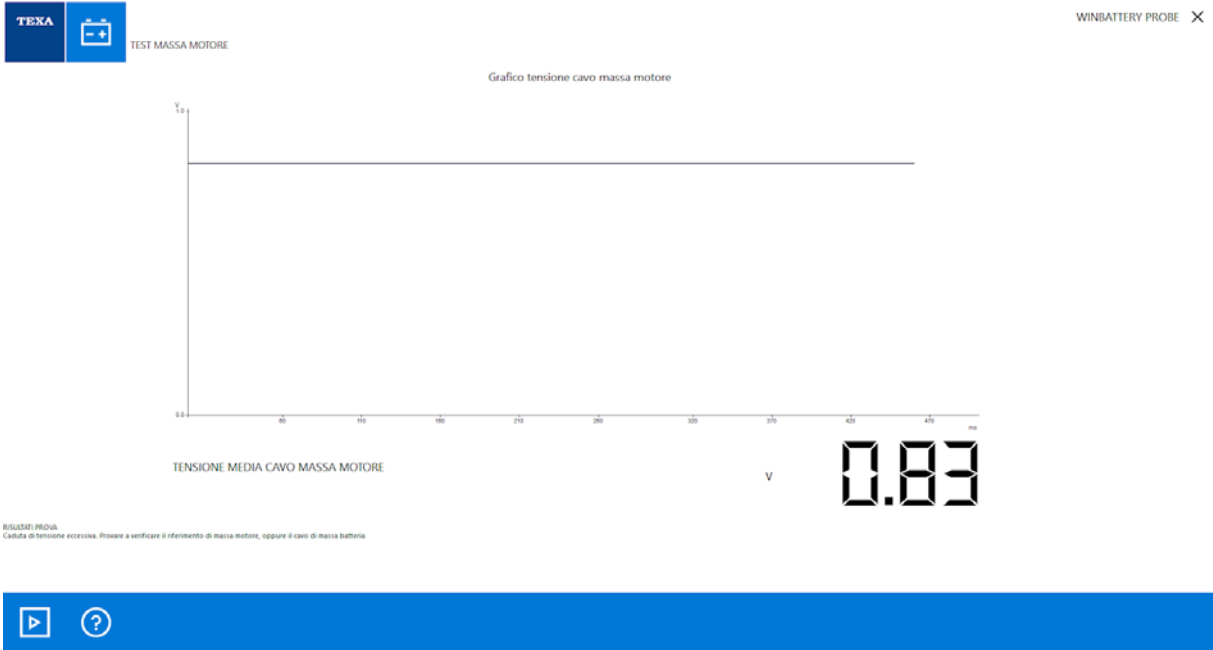

The screen provides the following information:

- *Engine ground cable voltage graph.*
- *Engine ground cable average voltage.*
- *Test result.*

57.3.3 Starter Motor + Test

This function allows you to check the voltage value of the battery and of the positive cable of the starter motor.

In order to carry out this test, you need the following material:



- *Device.*
- *BPP Cable.*
- *+MOT Cable.*
- *BICOR amperometric clamp.*

Proceed as follows:

1. Press: 

The main test screen is displayed.



Icons	Name	Description
	Start / Stop	It allows starting/stopping the test.
		
	Cable Connection	It allows you to launch a video regarding the connections that must be done.

2. Press: 

3. Connect the wirings to the tool and to the vehicle as illustrated in the video.

2. Press: 

4. Select the ammeter scale.



WINBATTERY PROBE X

Scala della pinza amperometrica

1 mV/A

10 mV/A

100 mV/A

1 V/A



6. Press:



4. Follow the instructions that appear on screen.



TEST + MOTORINO

WINBATTERY PROBE X

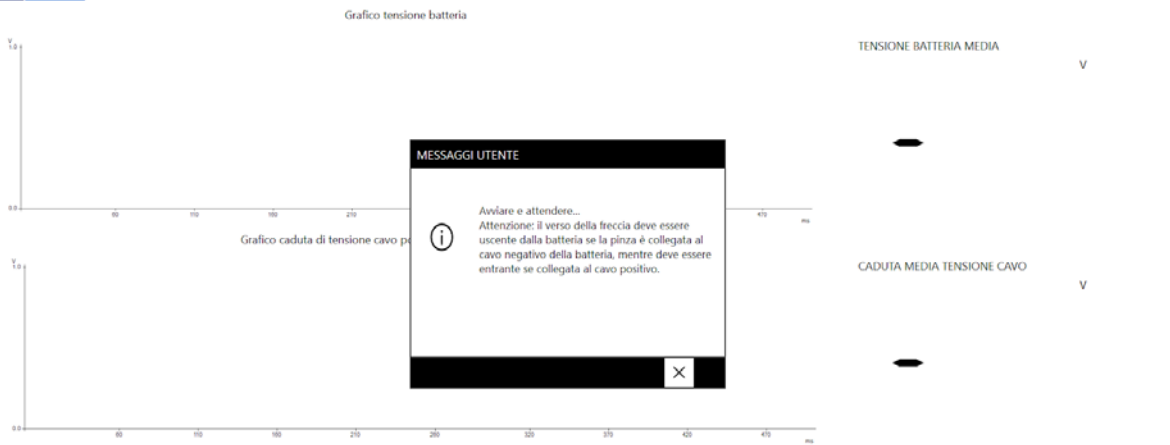

6. Wait for the result of the test.

The test result is displayed.

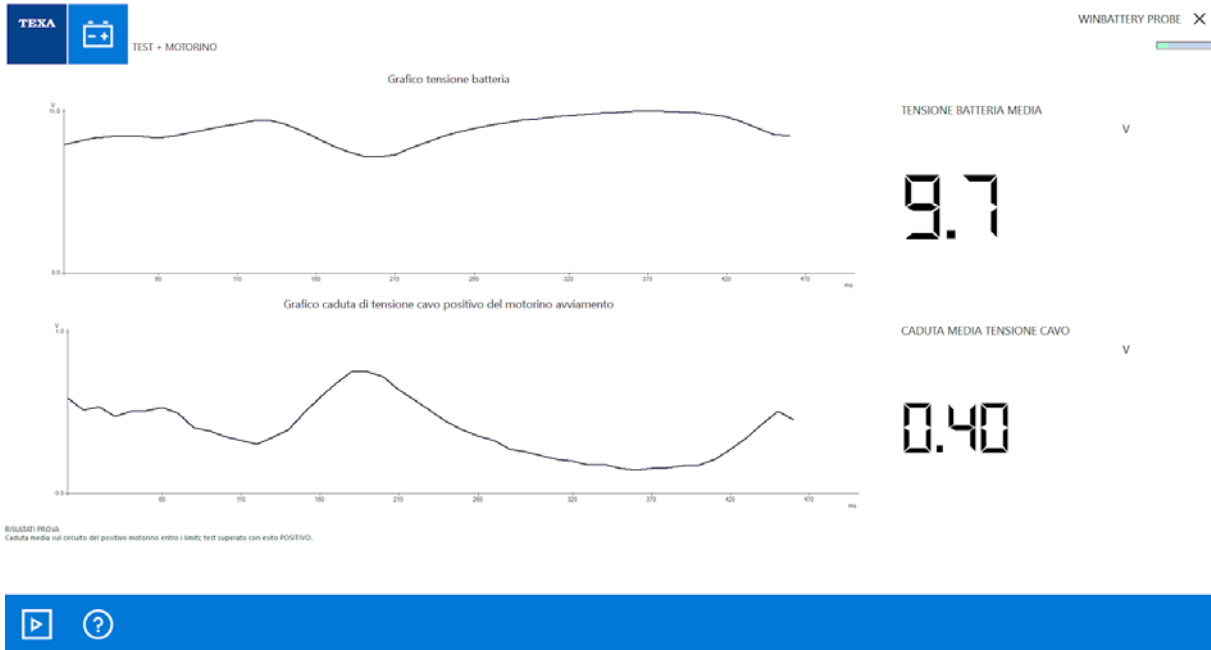

The screen provides the following information:

- *Battery voltage graph.*
- *Starter motor positive cable voltage drop graph.*
- *Average battery voltage.*
- *Cable voltage average drop.*
- *Test result.*

57.4 Result Summary

This function allows you to view the results of the performed tests.

Proceed as follows:

1. Press: 

The test report is displayed.

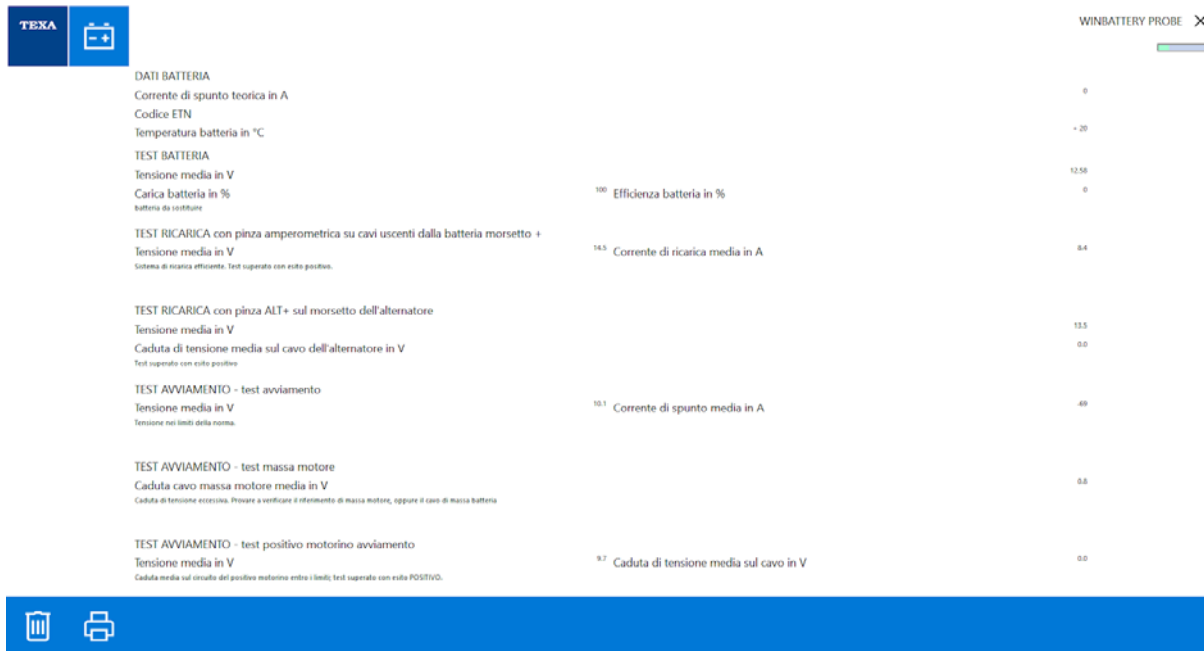

TEXA 

WINBATTERY PROBE 

DATI BATTERIA

- Corrente di spunto teorica in A: 0
- Codice ETN
- Temperatura batteria in °C: -20

TEST BATTERIA

- Tensione media in V: 12.58
- Carica batteria in % batteria da sostituire: 0
- ¹⁰⁰ Efficienza batteria in %: 0

TEST RICARICA con pinza amperometrica su cavi uscenti dalla batteria morsetto +

- Tensione media in V: 14.5
- ^{14.5} Corrente di ricarica media in A: 8.4

TEST RICARICA con pinza ALT+ sul morsetto dell'alternatore

- Tensione media in V: 13.5
- Caduta di tensione media sul cavo dell'alternatore in V: 0.0

TEST AVVIAMENTO - test avviamento



- Tensione media in V: 49
- ^{10.1} Corrente di spunto media in A: 49



TEST AVVIAMENTO - test massa motore

- Caduta cavo massa motore media in V: 0.0

TEST AVVIAMENTO - test positivo motorino avviamento

- Tensione media in V: 0.0
- ^{9.7} Caduta di tensione media sul cavo in V: 0.0

Icons	Name	Description
	Delete	It allows you to delete the test results.
	Print	It allows you to print a report containing all the results.

58 SIGNAL GENERATOR



This function allows to simulate the input and output signals of the ECUs used in cars. Proceed as follows:

1. Press: 

The main screen of the function is displayed.

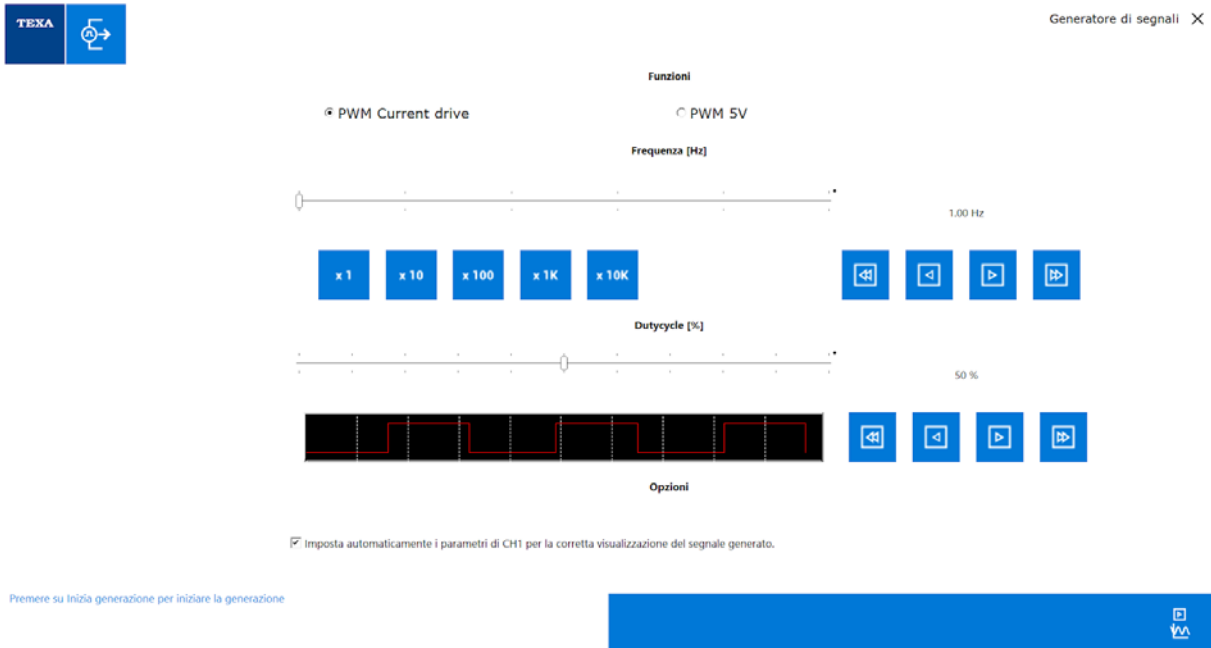

The screen is divided in the following sections:

- *Functions.*
- *Frequency.*
- *Duty Cycle*
- *Options.*

FUNCTIONS

The section **Functions** allows to choose the use mode of the generator.

The modes that can be selected are:

- *PWM CURRENT DRIVE;*
- *PWM 5V.*

To select a mode tick the box related to the desired mode.

FREQUENCY

The section **Frequency** allows selecting the frequency of the generated signal.

To select the frequency you can use the cursor or the following icons:

Icon	Name	Description
	Frequency cursor range	Allows to select the frequency cursor range.
	Back / Forward	Allows to decrease / increase the frequency.
	Fast rewind / Fast forward	Allowss to decrease / rapidly increase the frequency.

DUTY CYCLE

The section **Duty Cycle** allows selecting the duty cycle of the generated signal.

To select the duty cycle you can use the cursor or the following icons:

Icon	Name	Description
	Back / Forward	Allows to decrease / increase the duty cycle.
	Fast rewind / Fast forward	Allows to decrease / rapidly increase the duty cycle.

The software displays an image simulating the selected duty cycle.

OPTIONS

The section **Options** allows to prearrange the CH1 of the tool for a correct display of the generated signal.

To enable this function tick the corresponding box.

The following icons are also available:

Icon	Name	Description
	Start / Stop Generation	It allows starting / stopping the generation of the signal.

58.1 PWM CURRENT DRIVE

Mode **PWM CURRENT DRIVE** allows to test all the devices that work if activated by circulation of current (for example.: EGR valve, compressor of catalytic converter, etc.).

Proceed as follows:

1. Select: **PWM CURRENT DRIVE**

Generatore di segnali X

Funzioni

PWM Current drive PWM 5V

Frequenza [Hz]

1.00 Hz

x 1 x 10 x 100 x 1K x 10K

Duty cycle [%]

50 %

Options

Imposta automaticamente i parametri di CH1 per la corretta visualizzazione del segnale generato.

Premere su Inizia generazione per iniziare la generazione

2. Select **Frequency**.

3. Select **Duty Cycle**.

4. Press:

5. Follow the instructions that appear on screen.

Generatore di segnali X

Funzioni

PWM Current drive

Attenzione

Queste funzioni, se utilizzate in modo improprio, erroneo o negligente potrebbero, in alcuni casi, causare danni ai sistemi in esame.

12V Battery

Fan Motor

Battery Fuse

Fan Motor Earth

1.00 Hz

50 %



Imposta automaticamente i parametri di CH1 per la corretta visualizzazione del segnale generato.

Comunicazione in corso...

6. Press:

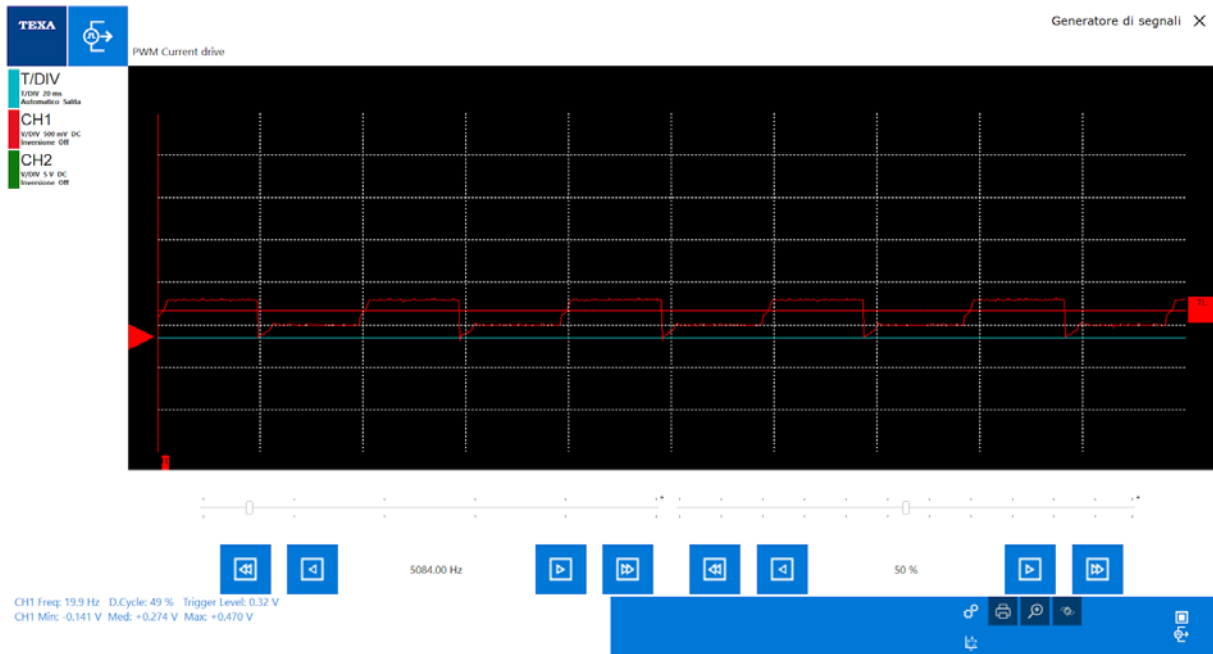
The generation of the signal and its display are launched.



Icon	Name	Description
	Start / Stop	It allows starting / stopping the oscilloscopic measurement.
		
	Stop Generation	Allows to stop the signal generation and go back to the screen of the signal generator parameters.

INFORMATION

Through the icons it is still possible to modify the Frequency and the Duty Cycle of the generated signal.

For further information, see the chapter: OSCILLOSCOPE

58.2 PWM 5V

PWM 5 V mode allows to simulate last generation sensors with 0-5 V PWM or PFM type signals. Proceed as follows:

1. Select: **PWM 5 V**

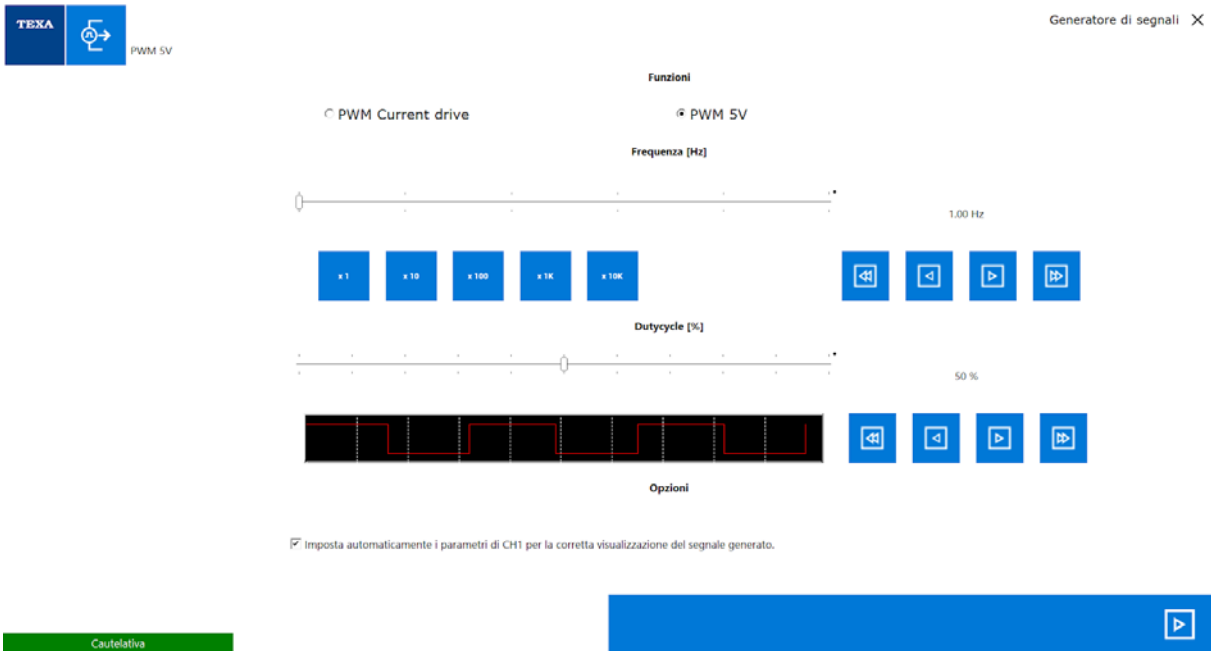

2. Select **Frequency**.

3. Select **Duty Cycle**.

4. Press:



5. Follow the instructions that appear on screen.

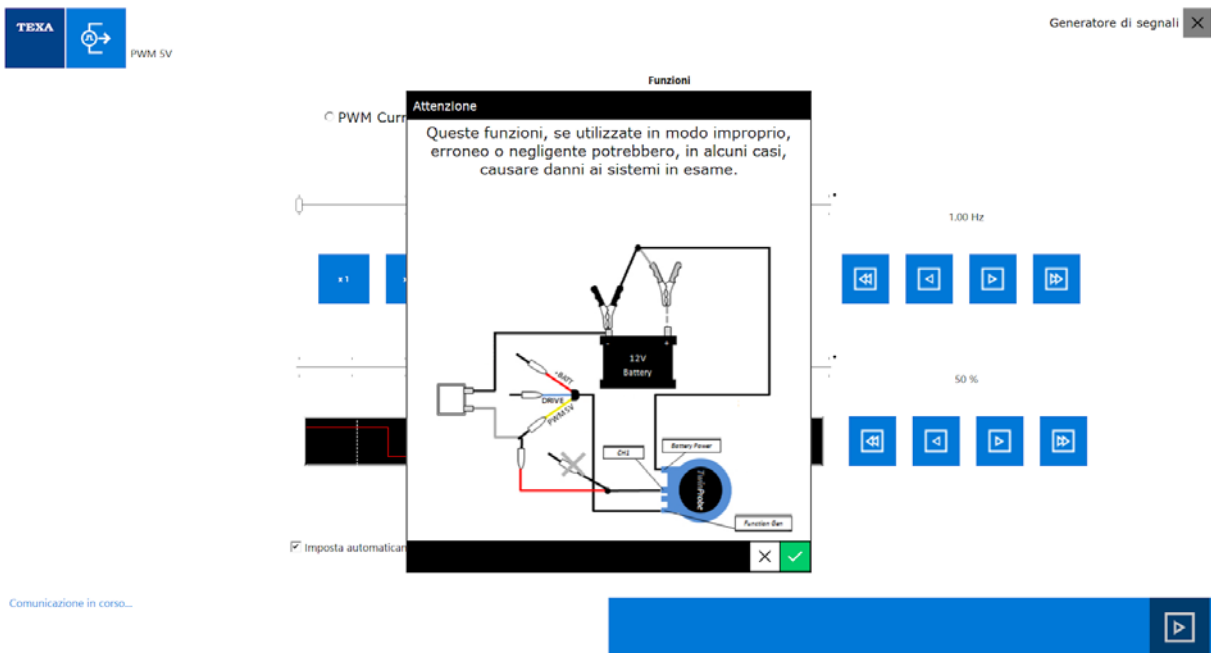



6. Press:

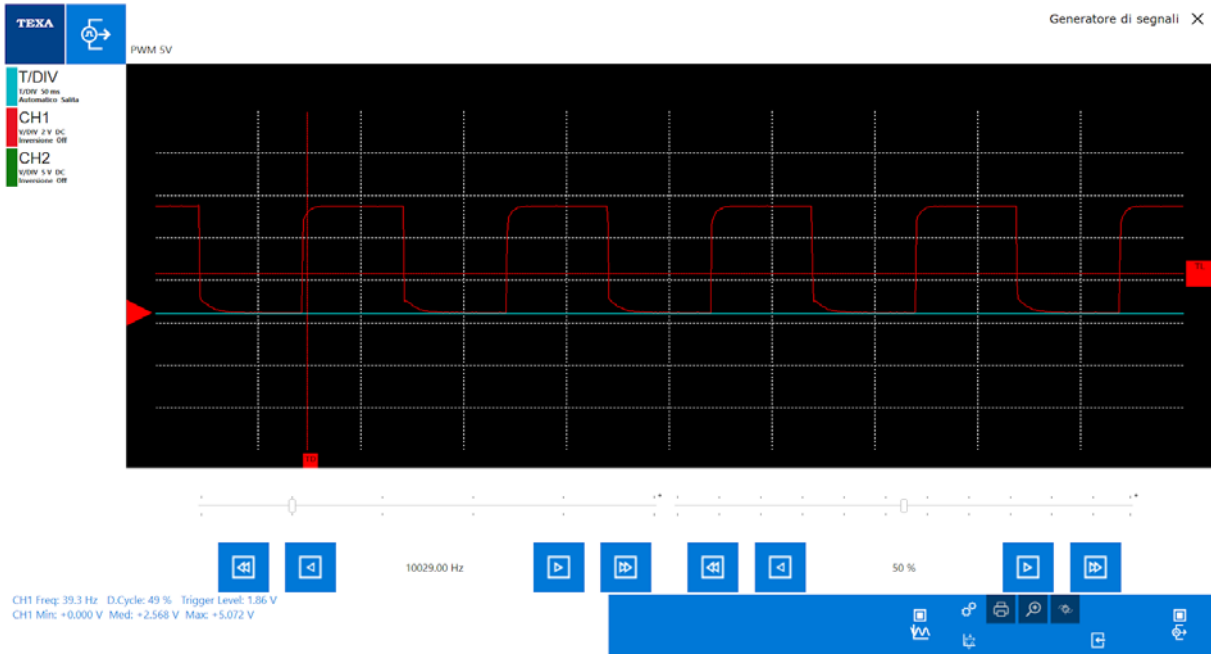

The generation of the signal and its display are launched.



Icon	Name	Description
	Start / Stop	It allows starting / stopping the oscilloscopic measurement.
		
	Stop Generation	Allows to stop the signal generation and go back to the screen of the signal generator parameters.

INFORMATION

Through the icons it is still possible to modify the Frequency and the Duty Cycle of the generated signal.

For further information, see the chapter: OSCILLOSCOPE

59 IGNITION



This function allows starting to measure the high voltages.

The software displays specific connection diagrams indicating the type and correct positioning of the wiring required for the measurement.

INFORMATION

The wiring required for the measurement and its positioning may vary based on the selection made.

Proceed as follows:





1. Press:

The main screen appears.

Enter the data related to the ignition system you want to diagnose and press CONFIRM



Icon	Name	Description
	Print	It allows printing a report of the test that has been performed.
	Data reset	It allows deleting the acquired data to repeat the measurement.
	Results	It allows displaying the measurement results.
	Invert Signal	It allows inverting the signal while it is being displayed graphically.
	Spark time	It allows analysing the duration of the spark.
	Spark voltage	It allows analysing the spark's voltage.

	Oscilloscope	It allows displaying graphically the voltage's trend during the ignition of the spark plugs.
	Simplified mode	It allows analysing the secondary circuit in all the ignition systems.
	Back	In allows interrupting the measurement and returning to the main screen.
	Confirm	It allows confirming the entered data.

2. Use the dropdown menus to select:

- *Engine type*
- *Firing order*
- *Ignition system*
- *Specification*

×

Engine type
4-cylinder in-line

Firing order
1-3-4-2

Ignition system
Waste spark with ignition cables

Specification
With electronic module

Enter the data related to the ignition system you want to diagnose and press CONFIRM



3. Press:



4. Follow on screen instructions



×

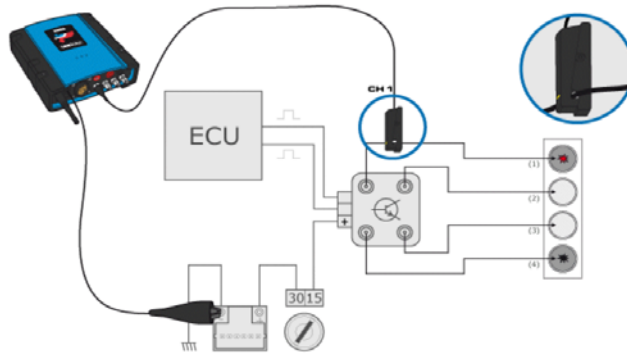

Connect the Trigger clamp to cylinder 1 with arrow pointing toward the spark plug.
Turn on the engine and press CONFIRM.



5. Press:



6. Follow on screen instructions



×

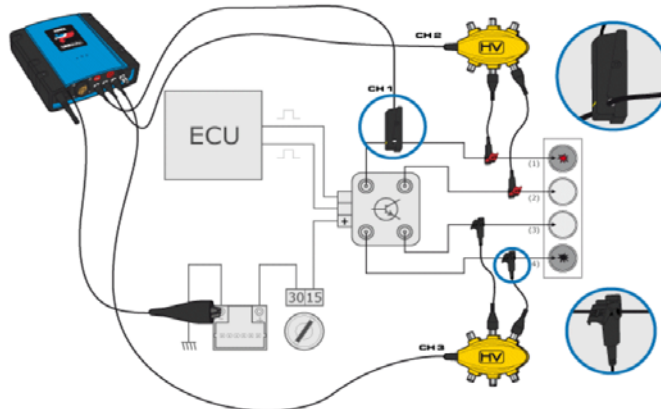

Synchronization identified. Connect the cables as shown in the image and press CONFIRM in order to start the diagnosis.



1. Press:



The measuring process has been started.

59.1 Spark time

This function allows analysing the duration of the spark by each spark plug / in each cylinder. Proceed as follows:

1. Press: 

The screen with the requested data appears.

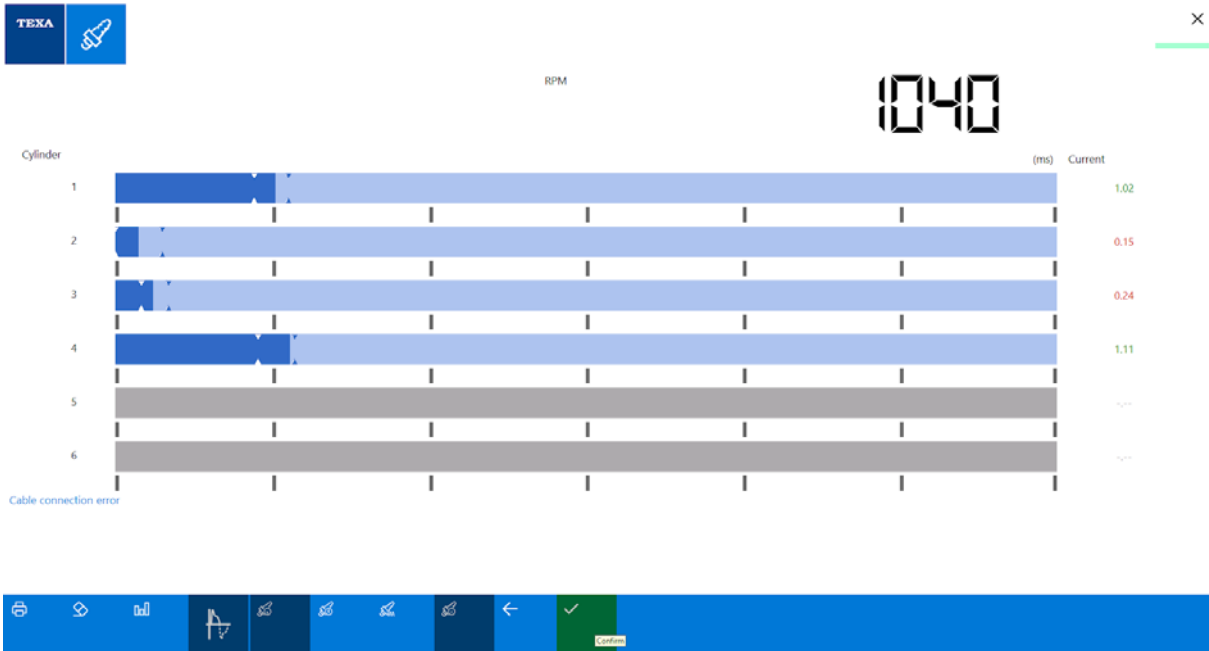

This screen indicates the following in real time:

- *engine speed (rpm);*
- *spark time (ms);*
- *current (A).*

The software graphically indicates the maximum and minimum values reached.

INFORMATION

Based on the connection, the data can refer to:

- *the specific spark plug;*
- *the cylinder.*

59.2 Spark voltage

This function allows analysing the voltage of the spark by each spark plug / in each cylinder. Proceed as follows:

1. Press: 

The screen with the requested data appears.

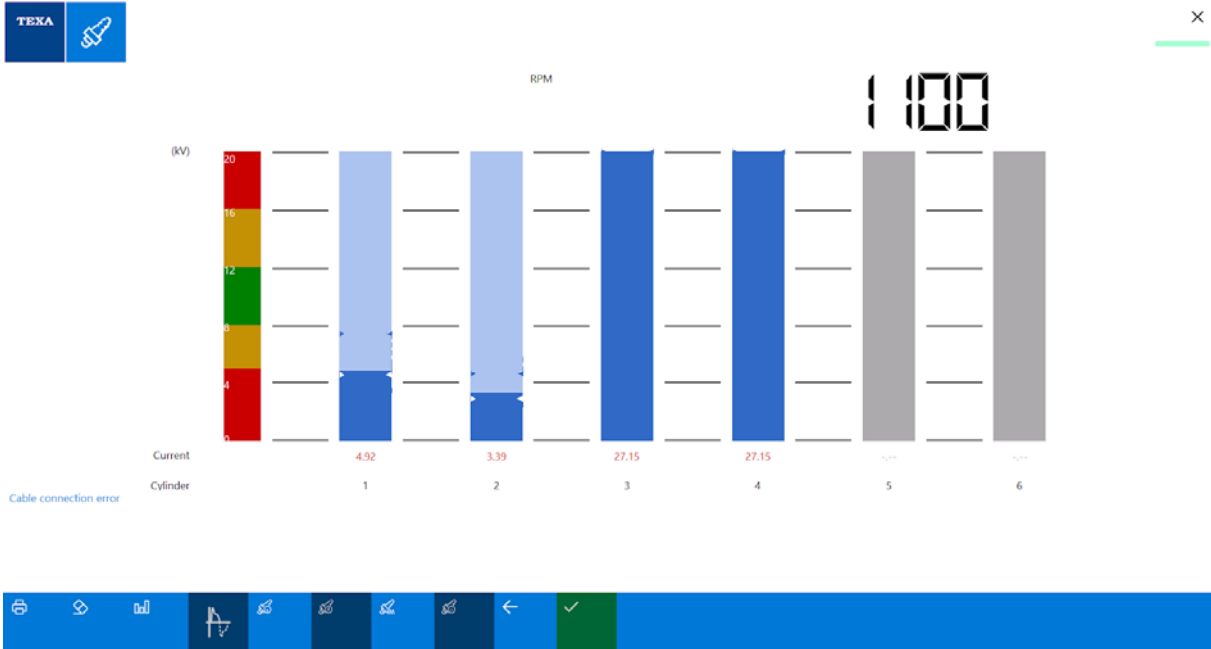

This screen indicates the following in real time:

- engine speed (rpm);
- spark ignition (kV);
- current (A).

The software graphically indicates the maximum and minimum values reached.

INFORMATION

Based on the connection, the data can refer to:

- the specific spark plug;
- the cylinder.

59.3 Oscilloscope

This function allows displaying graphically the voltage's trend during the ignition of the spark plugs. Proceed as follows:

1. Press: 

The screen with the requested data appears.

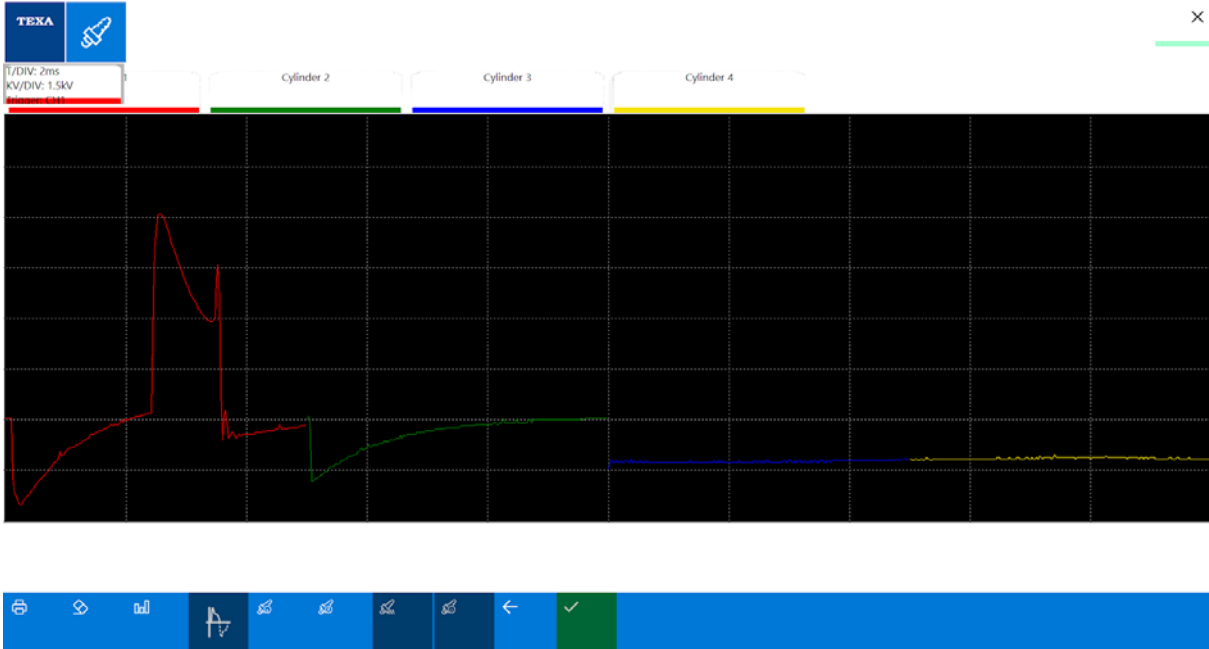

The software displays the voltage's trend over time.

INFORMATION

Based on the connection, the data can refer to:

- *the specific spark plug;*
- *the cylinder.*

59.4 Simplified mode

This function allows analysing the secondary circuit in all the ignition systems.

In this mode the cylinders are analysed one at a time.

Proceed as follows:

1. Press: 
2. Press: **OK**

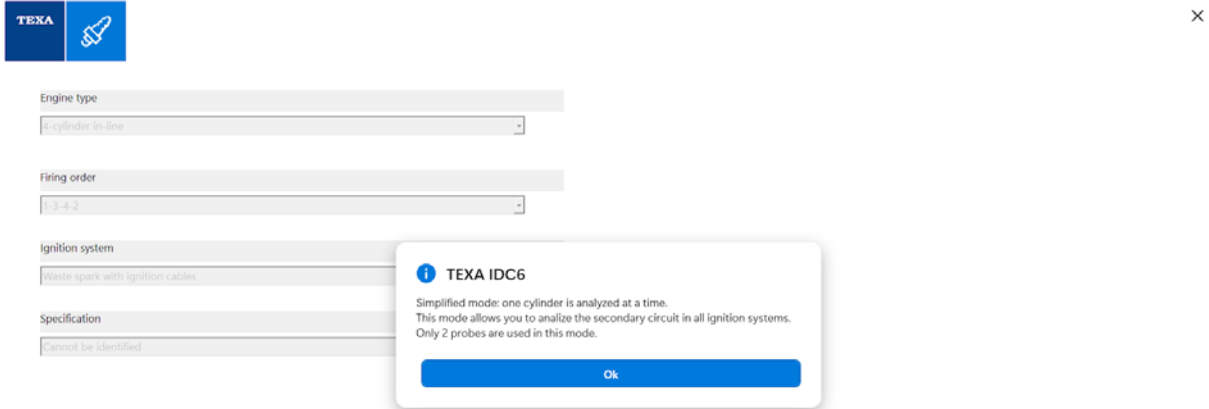

Enter the data related to the ignition system you want to diagnose and press CONFIRM



2. Follow the instructions that appear on screen.

INFORMATION

The procedure follows the same steps described above for measurements on more than one cylinder simultaneously.

59.5 Results

This function allows displaying the measurement results.

Proceed as follows:

1. Press: 

The screen with the results appears.

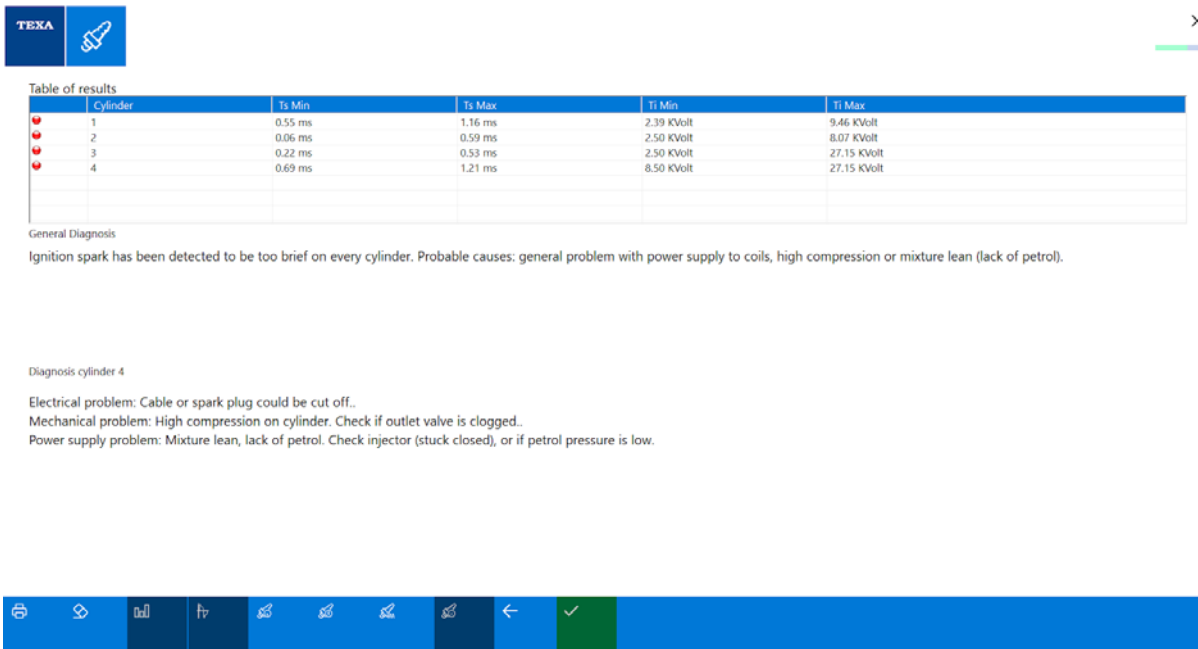

The screenshot shows the TEXA diagnostic software interface. At the top left is the TEXA logo and a wrench icon. A close button (X) is in the top right. Below the logo is a 'Table of results' table with the following data:

Cylinder	Ts Min	Ts Max	Ti Min	Ti Max
1	0.55 ms	1.16 ms	2.39 kVolt	9.46 kVolt
2	0.06 ms	0.59 ms	2.50 kVolt	8.07 kVolt
3	0.22 ms	0.53 ms	2.50 kVolt	27.15 kVolt
4	0.69 ms	1.21 ms	8.50 kVolt	27.15 kVolt

Below the table is a 'General Diagnosis' section with the text: 'Ignition spark has been detected to be too brief on every cylinder. Probable causes: general problem with power supply to coils, high compression or mixture lean (lack of petrol).'.

Below that is a 'Diagnosis cylinder 4' section with the following text: 'Electrical problem: Cable or spark plug could be cut off.', 'Mechanical problem: High compression on cylinder. Check if outlet valve is clogged.', and 'Power supply problem: Mixture lean, lack of petrol. Check injector (stuck closed), or if petrol pressure is low.'

At the bottom of the screen is a navigation bar with various icons, including a green checkmark icon.

The software provides a general diagnosis on the system and indicates the possible cause of any malfunctions.

By selecting the specific cylinder, the problems found and related causes are indicated.

60 PRESSURES



This function allows taking a series of pressure measurements.

INFORMATION

Running the tests requires using a measuring kit that includes specific cables and a pressure sensor.

The software requires performing the pressure sensor calibration at each new start-up.

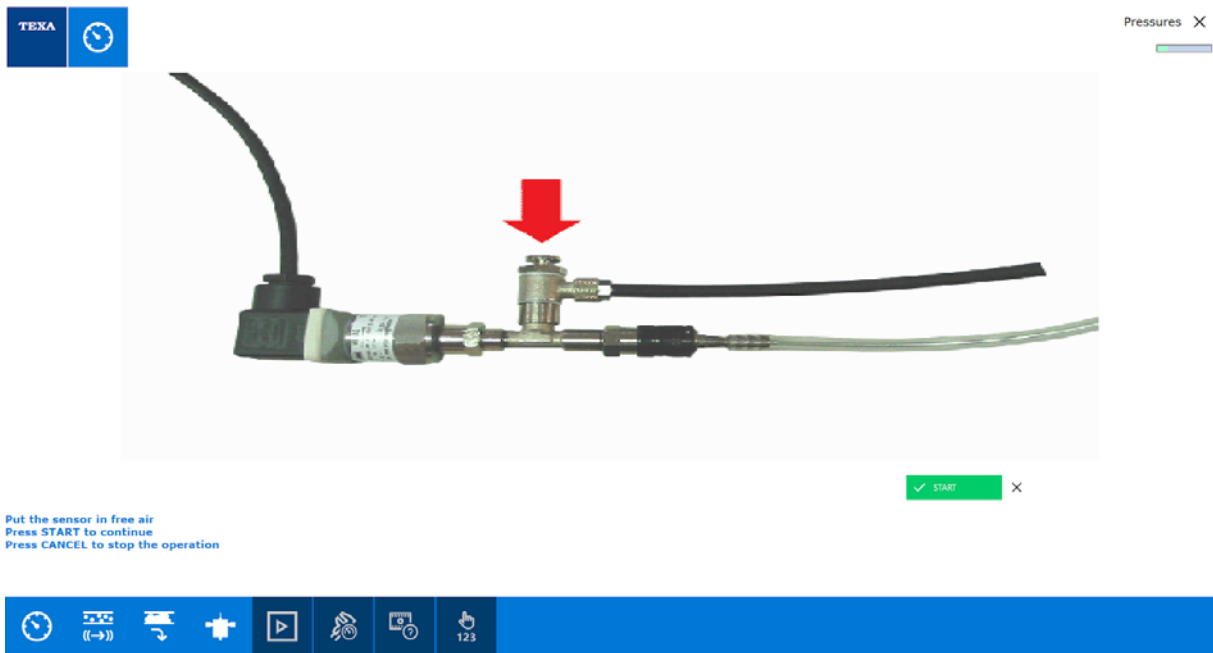

Proceed as follows:

1. Press:



Put the sensor in free air
Press START to continue
Press CANCEL to stop the operation



Icon	Name	Description
	Pressure detection	It allows taking a continuous measurement of the pressure within the circuit being tested.
	Cavitation	It allows checking for rapid pressure variations within the circuit being tested.
	Leak test	It allows checking that the operating pressure does not decrease more than 30% during the test period (about 10 minutes).
	Vacuum Pump	It allows checking the incidence of the vacuum pump on the pressure within the circuit being tested.
	Start / Stop	It allows starting or stopping the measurement.

	Calibration	It allows calibrating the pressure sensor before running a test.
	Cable connection	It allows seeing a video that shows the connection of the cables needed for the tests.
	Manual data	It allows entering the pressure limit values for the tests manually.

60.1 Pressure Detection

This function allows taking a continuous measurement of the pressure within the circuit being tested.

Proceed as follows:

1. Press: 
2. If requested, perform the pressure sensor calibration.
3. Press: 
4. Enter the pressure limit values for the test.

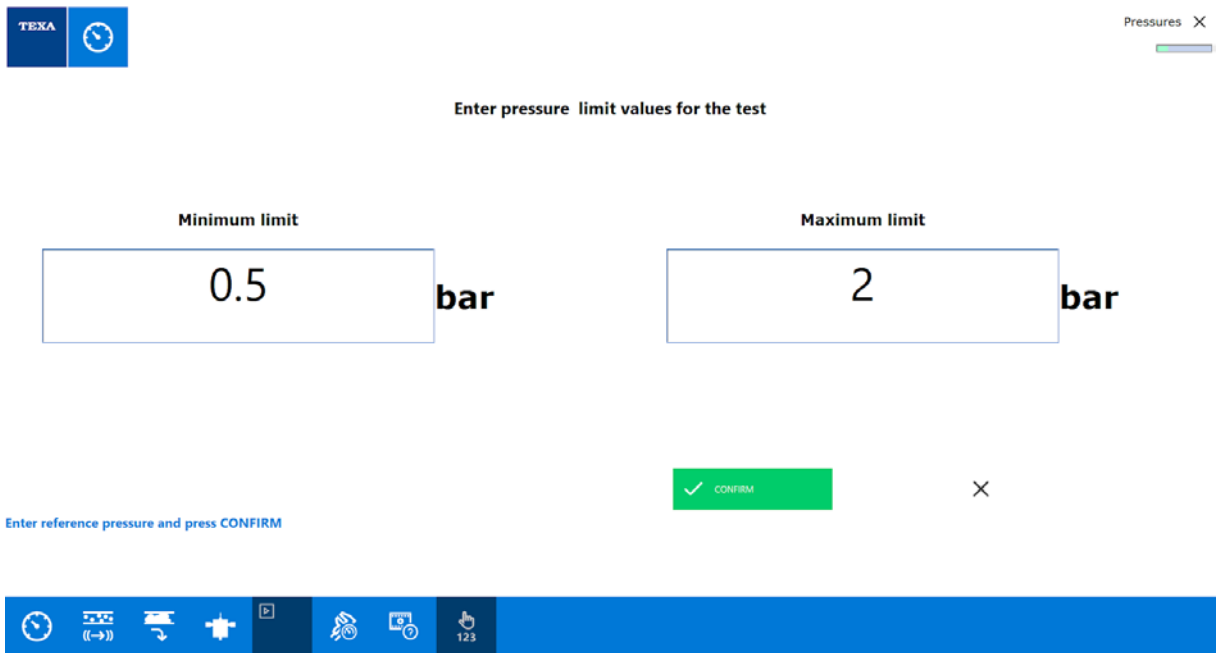

TEXA  Pressures X

Enter pressure limit values for the test

Minimum limit bar

Maximum limit bar

CONFIRM X

Enter reference pressure and press CONFIRM

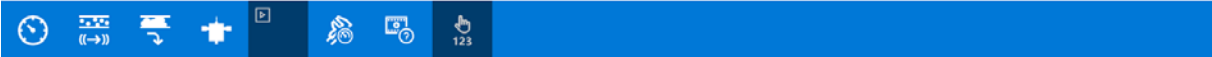

5. Press: 

6. Connect the sensor to the hydraulic system that needs to be checked, being careful to position it away from disturbance sources like: ignition coils, spark plug cables, etc.

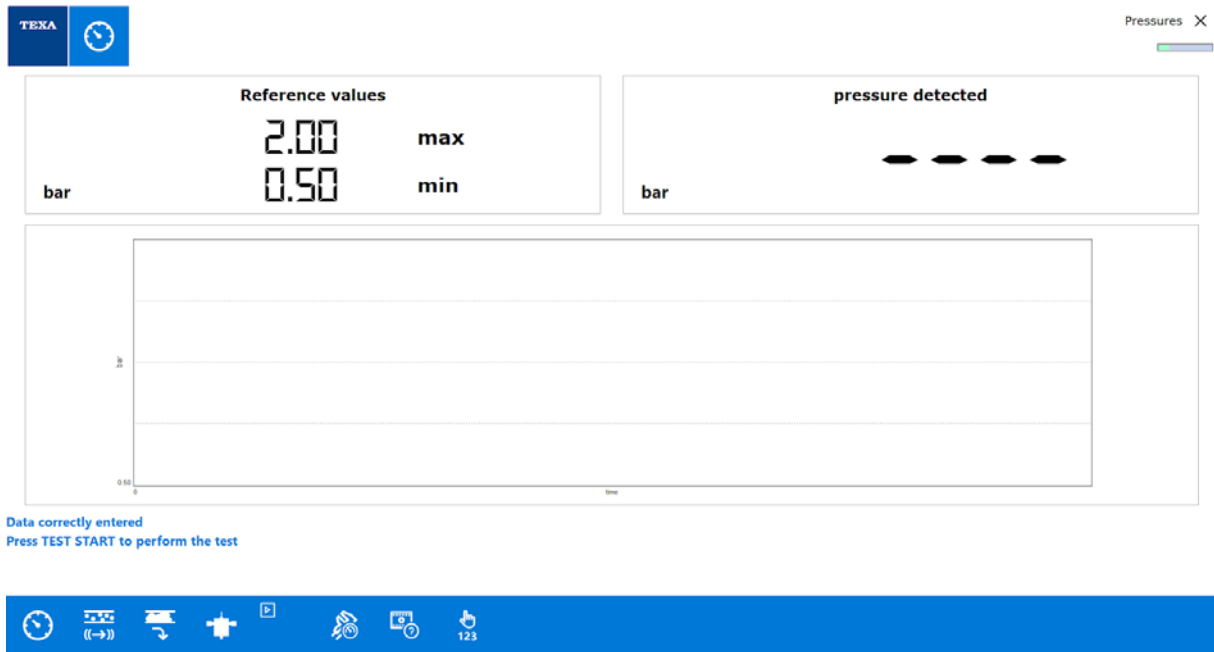

7. Press:



The test is launched.

If the detected pressure value is out of the set limits, its colour turns from blue to orange.

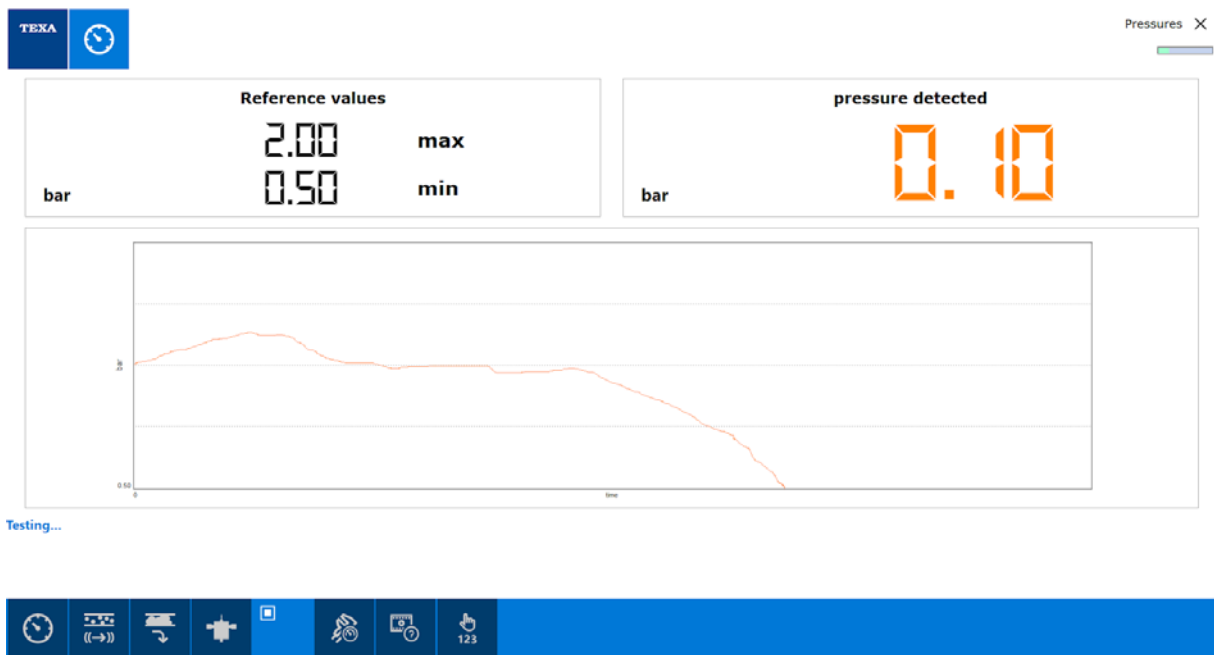

8. To stop measuring, press:



60.2 Cavitation

This function allows checking for rapid pressure variations within the circuit being tested.

This rapid variation can be generated by pressure voids, caused by pumps not properly primed. This rapid variation could also be caused by a sudden blocking perhaps due to a bent pipe caused by potholes, speed bumps etc...

Proceed as follows:

1. Press: 

2. Press: 

The test is launched.

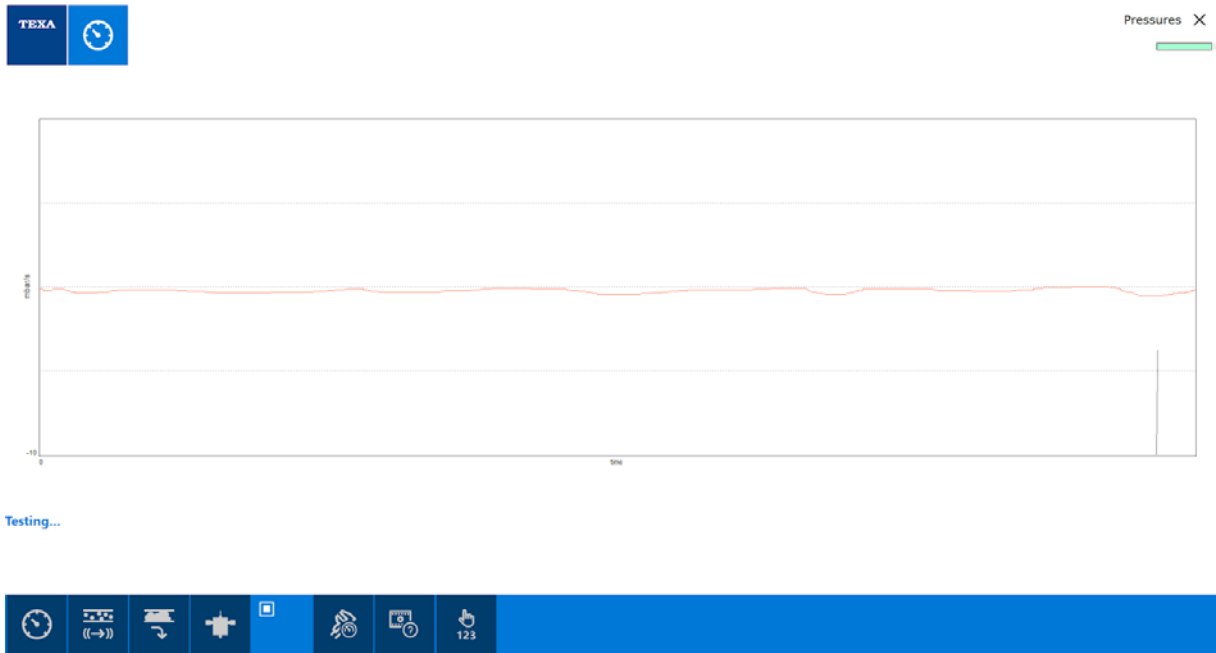

Through a graph, the software displays the pressure's trend highlighting any variations, which indicate a failure.

3. To stop measuring, press: 

60.3 Leak Test

This function allows checking that the operating pressure does not decrease more than 30% during the test period (about 10 minutes).

INFORMATION

"Operating pressure" refers to the pressure within the circuit when the vehicle engine is off.

Proceed as follows:

1. Press: 
2. If requested, perform the pressure sensor calibration.

3. Press: 



Perform the reset procedure
Press the CALIBRATION key



4. Enter the pressure limit value for the test.



Enter reference pressure and press CONFIRM





5. Press: 

6. Press: 

The test is launched.

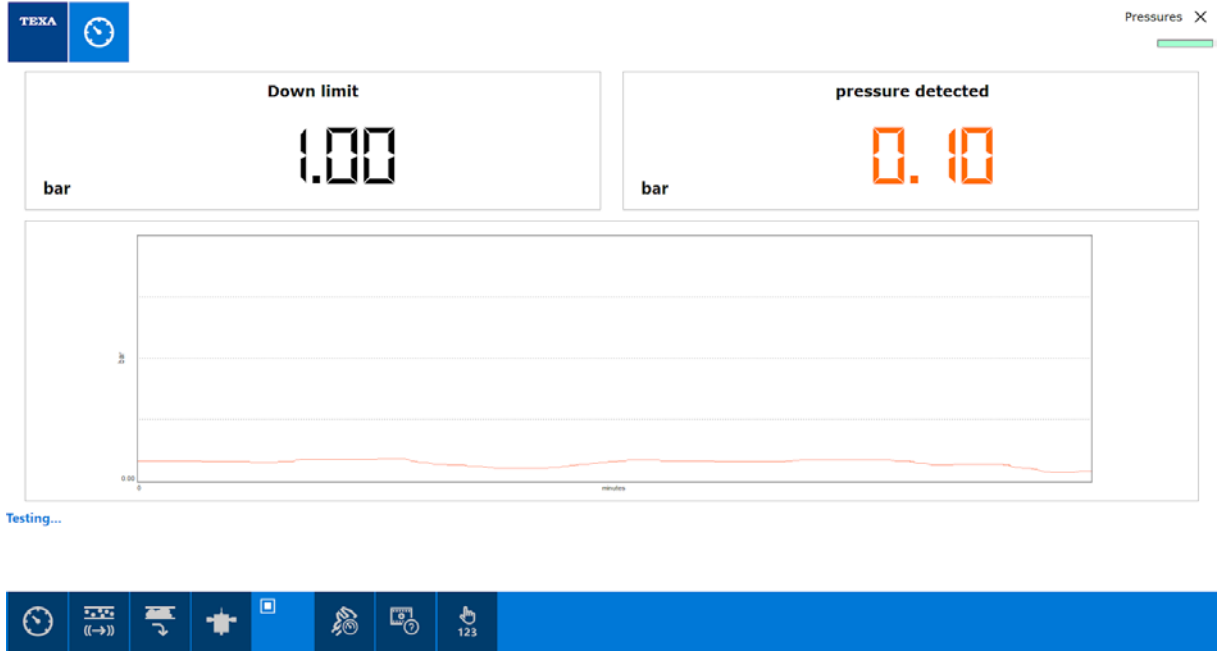
If the detected pressure value is out of the set limits, its colour turns from blue to orange.



7. To stop measuring, press: 

60.4 Vacuum Pump

This function allows checking the incidence of the vacuum pump on the pressure within the circuit being tested.

The software takes a measurement with the vacuum pump engaged and another without the vacuum pump, it calculates the difference and compares it with a reference value.

INFORMATION

The test is successful if the calculated value is equal to the reference value ± 0.10 bar.

Proceed as follows:

1. Press: 
2. If requested, perform the pressure sensor calibration.

3. Press: 

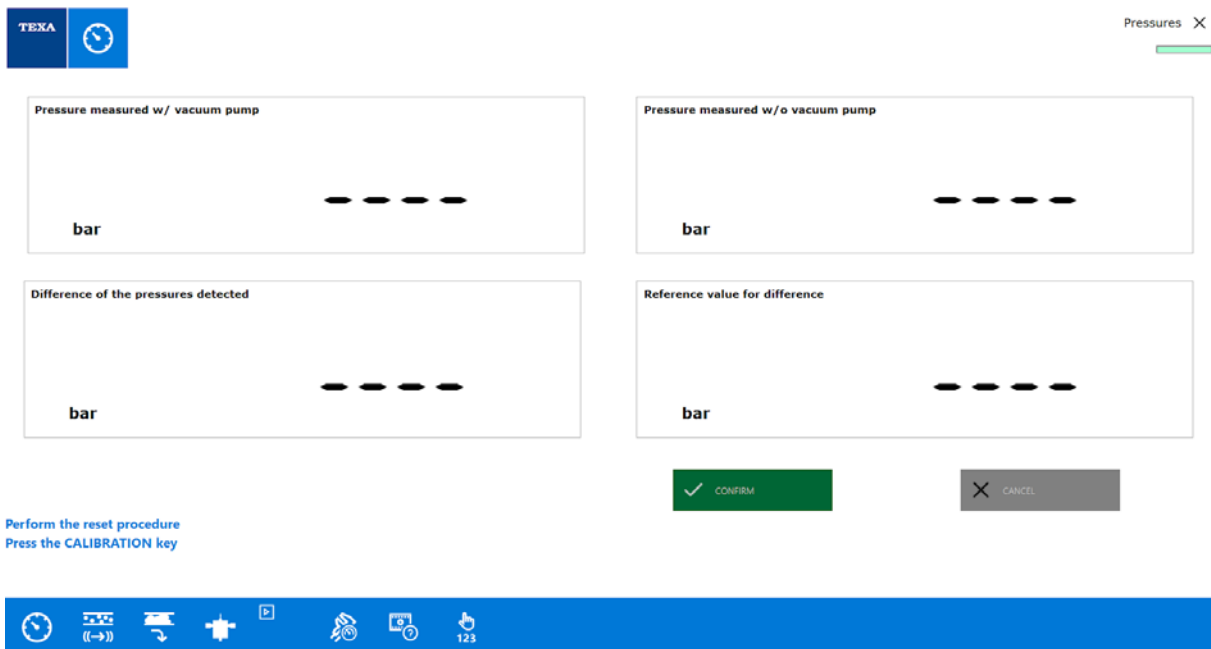

The screenshot shows the software interface for the vacuum pump test procedure. At the top left, there is a 'TEXA' logo and a circular icon with a refresh symbol. At the top right, there is a 'Pressures X' label and a green progress bar. The main area contains four input fields, each with a label and a 'bar' unit, and a set of four horizontal dashes for data entry:

- Pressure measured w/ vacuum pump
- Pressure measured w/o vacuum pump
- Difference of the pressures detected
- Reference value for difference

At the bottom right, there are two buttons: a green 'CONFIRM' button with a checkmark and a grey 'CANCEL' button with an 'X' icon. Below the input fields, there is a blue text instruction: 'Perform the reset procedure Press the CALIBRATION key'. At the bottom of the screen, there is a blue navigation bar with several icons: a clock, a double arrow, a refresh symbol, a calibration icon, a play button, a hand icon, a hand icon with a number, and the number '123'.

4. Enter the pressure limit value for the test.



Pressures X

Enter the pressure limit value

0.5 bar

CONFIRM

X



5. Press:



6. Follow on screen instructions



Pressures X

Pressure measured w/ vacuum pump
0.96
bar

Pressure measured w/o vacuum pump

bar

Difference of the pressures detected

bar

Reference value for difference
0.50
bar

CONFIRM

X

Switch On the engine and keep it at ticking-over.
Press CONFIRM to continue, press CANCEL to repeat the operation



7. Press:



8. Follow on screen instructions

Pressure measured w/ vacuum pump: 0.96 bar

Pressure measured w/o vacuum pump: 1.15 bar

Difference of the pressures detected: - - - -

Reference value for difference: 0.50 bar

CONFIRM

Disconnect the adjuster hose.
Press CONFIRM to continue, press CANCEL To repeat the operation

9. Press:

The test result is displayed.

Pressure measured w/ vacuum pump: 0.96 bar

Pressure measured w/o vacuum pump: 1.15 bar

Difference of the pressures detected: 0.19 bar

Reference value for difference: 0.50 bar

CONFIRM CANCEL

TEST FAILED. Pressure variation out of tolerance by +/- 0.10 bar compared to the reference value. Regulator not working. Reconnect the hose.

60.5 Calibration

This function allows calibrating the pressure sensor before running a test.

The calibration is required in order to carry out the following properly:

- *Pressure detection*
- *Leak test*
- *Vacuum Pump*

INFORMATION

The software requires performing the pressure sensor calibration at each new start-up.

The calibration can be performed at any time.

Proceed as follows:

1. Press: 
2. Follow on screen instructions

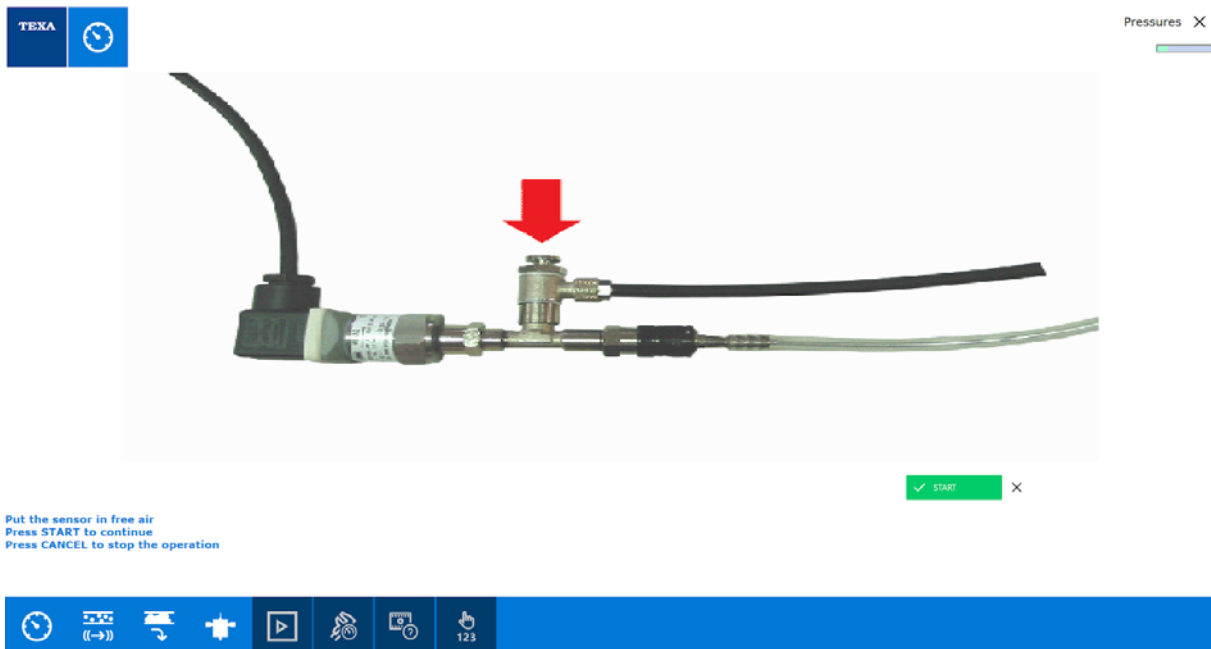

3. Press: 
- Wait for the calibration to complete.

61 TDS



TDS is a software that allows carrying out an analysis on a vehicle's brake disc and tyre tread wear easily and professionally, by means of a specific measuring tool.

INFORMATION

*The software must be installed separately from IDC6.
The icon in IDC6 acts as a link and allows launching TDS directly.*

Proceed as follows:

1. Press: 

The software is launched.

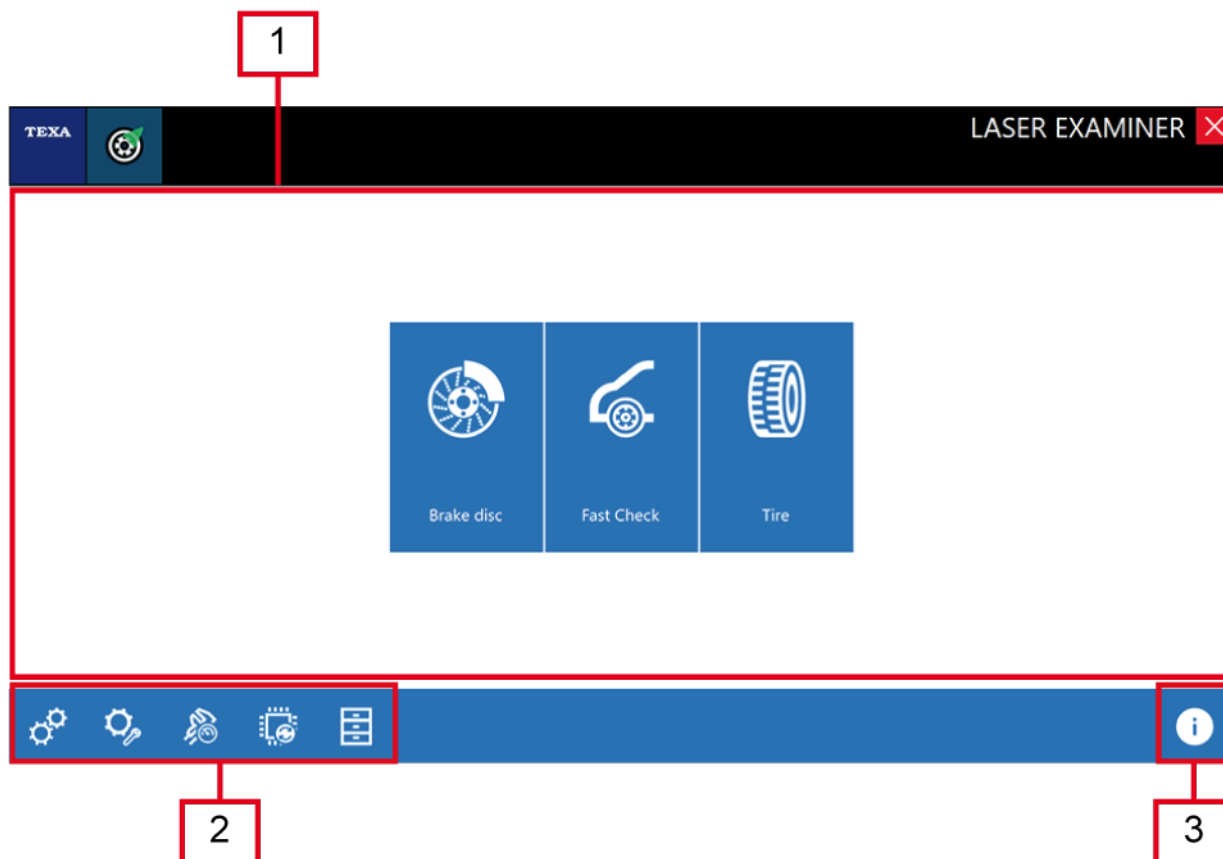

The screen below is the software **HOME** screen.

The **HOME** screen allows you to launch all the functions available in the software.



The screen is divided into:





1.FUNCTIONS MENU

Icon	Name	Description
	Brake disc	It allows you to measure the wear of the brake discs on a vehicle.
	Fast Check	It allows you to measure the brake disc wear and the tread depth on a vehicle's tyres in sequence.
	Tire	It allows you to measure the tread depth on a vehicle's tyres.

2.SETTINGS MENU

The *Settings* menu allows you to:

- *configure the parameters relating to the software operation;*
- *enter the workshop data;*
- *update the firmware on the measuring tool;*
- *carry out periodical tests on the measuring tool;*
- *archive and manage the measurement reports.*

Icon	Name	Description
	Settings	It allows you to configure the operating parameters for the software and the measuring tool.
	Workshop data	It allows you to enter the workshop information that will appear in the printed reports.
	Periodical checks	It allows you to carry out periodical checks on the measuring tool.
	Firmware update	It allows you to update the firmware version of the measuring tool.
	Test archive	It allows you to manage the measurement reports sorting them by plate, date and time.

3.INFORMATION

This menu provides information on the tool's software and firmware.

Proceed as follows:

1. Press: 

The following information is displayed:

- *software version;*
- *measuring tool's firmware version.*

61.1 Preliminary Operations

Before starting to use the software:

1. Configure the parameters correctly in the *Settings* menu.

The *Settings* screen appears automatically when the software is launched for the first time.

For further information see the related chapter.

2. Check the tool's battery charge.

Recharge the tool if necessary.

For further information on the charging times, see the tool's technical manual.

3. Make sure the Bluetooth communication is enabled on the display unit.

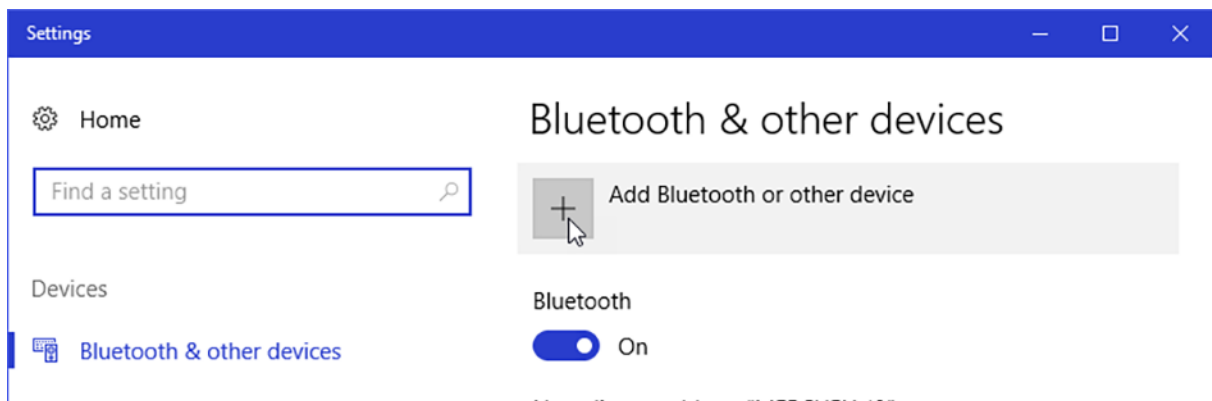

61.2 Brake disc

This function allows you to measure the wear of the brake discs on a vehicle.

Proceed as follows:

1. Turn on the tool.

2. Press: 

The software displays a vehicle outline where the brake disc that is expected to be measured is highlighted.

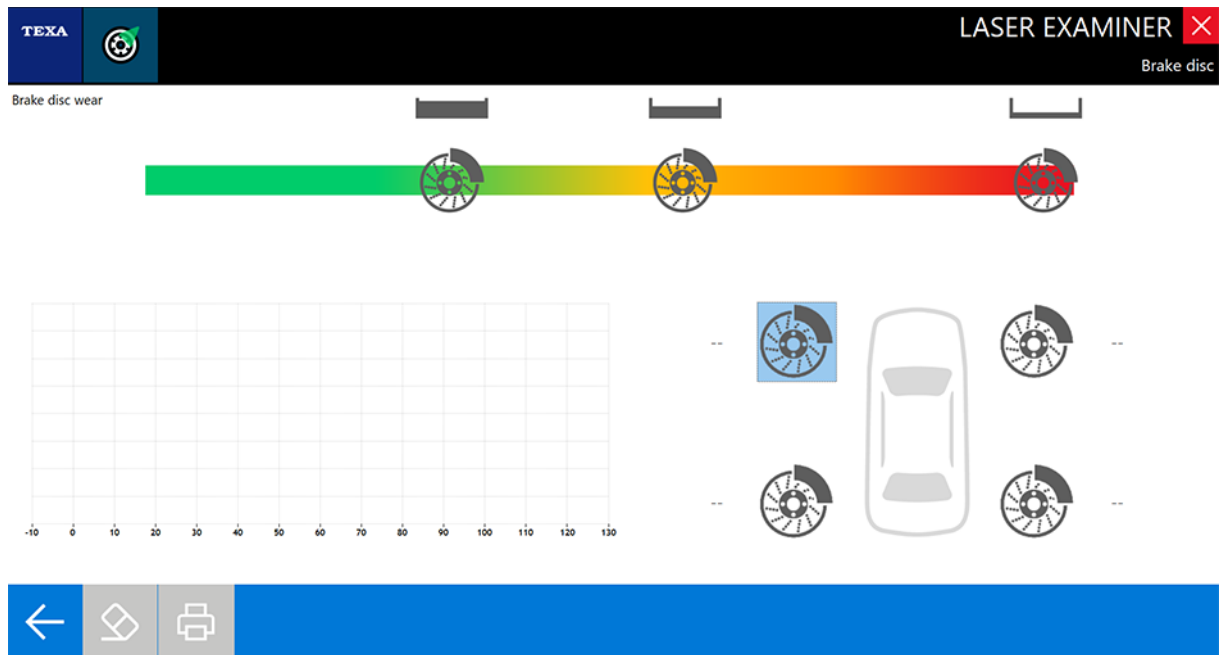

3. Position the tool on the brake disc as indicated in the technical manual.
4. Press the tool's power button to activate the laser.
5. Make sure there is not a wheel spoke in between the laser beam and the brake disc.
6. Direct the tool so that the laser beam is as aligned as possible with the centre of the brake disc.
7. Press the tool's power button to activate the micro-camera.
After the activation of the micro-camera, a beep indicates that the reading has been performed.
A second beep confirms that the data has been sent to the software correctly.
8. Proceed with the measurement on the other brake discs.

The test result is displayed.

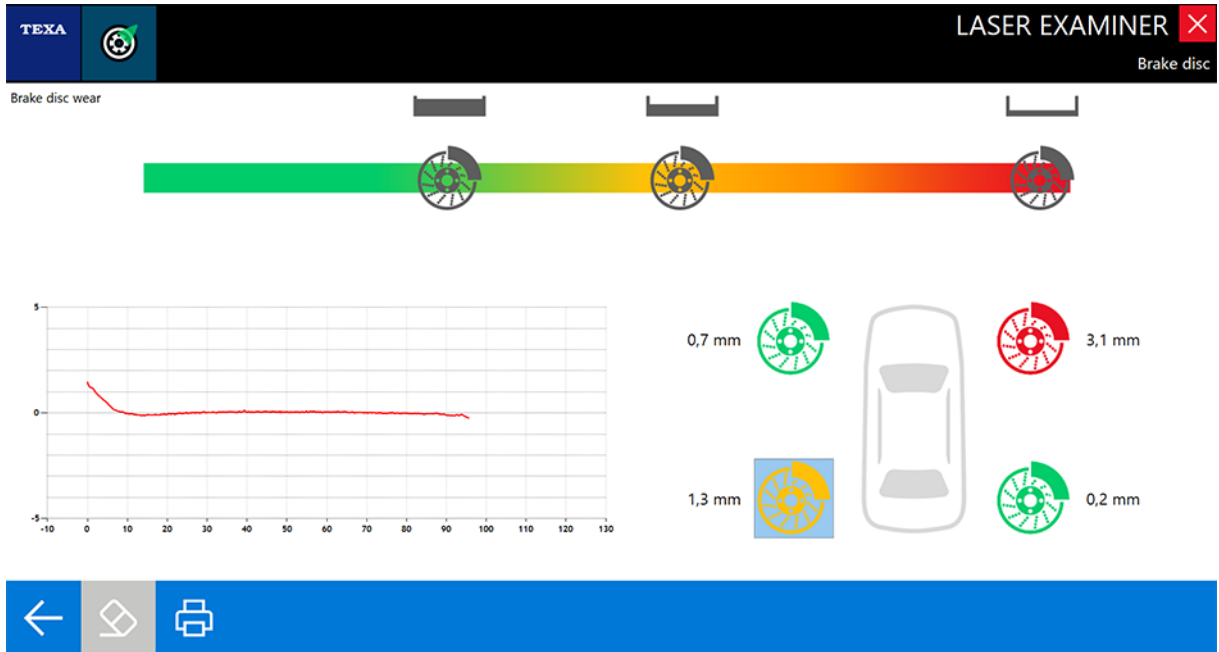

Icon	Name	Description
	Back	It allows you to return to the previous page.
	Erase	It allows you to erase a measurement in order to repeat it.
	Save	It allows you to save the entered data.

The measurement result is displayed graphically and the brake discs are highlighted with a colour that indicates:

	Brake disc wear not detected or waiting for measurement.
	The brake disc wear is within the limits entered in the <i>Settings</i> menu.
	The brake disc wear is close to the limit entered in the <i>Settings</i> menu.
	The brake disc wear does not respect the limit entered in the <i>Settings</i> menu. We recommend replacing the brake disc.

61.3 Fast Check

This function allows you to measure the brake disc wear and the tread depth on a vehicle's tyres in sequence.

Proceed as follows:

1. Turn on the tool.

2. Press: 

The software displays a vehicle outline where the brake disc that is expected to be measured is highlighted.

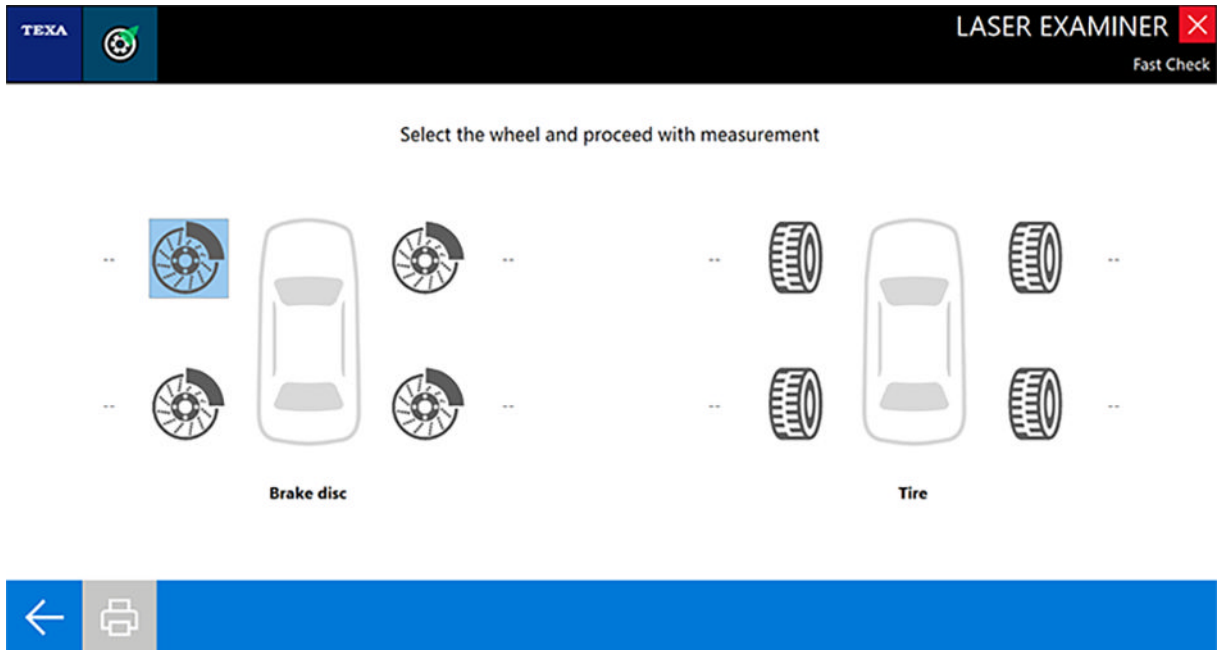

3. Position the tool on the brake disc as indicated in the technical manual.
4. Press the tool's power button to activate the laser.
5. Press the power button to activate the micro-camera.
After the activation of the micro-camera, a beep indicates that the reading has been performed.
A second beep confirms that the data has been sent to the software correctly.
6. Proceed with the measurement on the other brake discs.
7. Insert the tool's magnet into the specific housing on the adapter.
8. Position the tool on the tyre as indicated in the technical manual.
9. Press the tool's power button to activate the laser.
10. Press the power button to activate the micro-camera.
After the activation of the micro-camera, a beep indicates that the reading has been performed.
A second beep confirms that the data has been sent to the software correctly.
11. Proceed with the measurement on the other tyre treads.

The test result is displayed.



Select the wheel and proceed with measurement

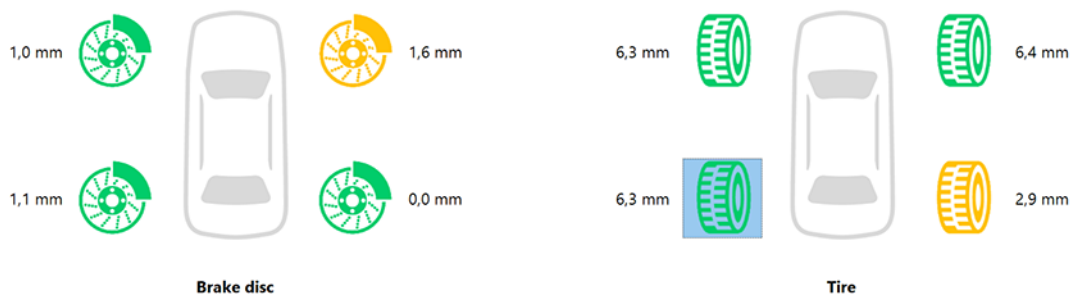

Icon	Name	Description
	Back	It allows you to return to the previous page.
	Print	It allows you to print the report.

The measurement result is displayed graphically and the brake discs / tyres are highlighted with a colour that indicates:

		Brake disc / tyre wear not detected or waiting for measurement.
		The brake disc / tyre wear is within the limits entered in the <i>Settings</i> menu.
		The brake disc / tyre wear is close to the limit entered in the <i>Settings</i> menu.
		The brake disc / tyre wear does not respect the limit entered in the <i>Settings</i> menu. We recommend replacing the brake disc / tyre.

61.4 Tire

This function allows you to measure the tread depth on a vehicle's tyres.

Proceed as follows:

1. Insert the tool's magnet into the specific housing on the adapter.
2. Turn on the tool.

3. Press: 

The software displays a vehicle outline where the brake disc that is expected to be measured is highlighted.

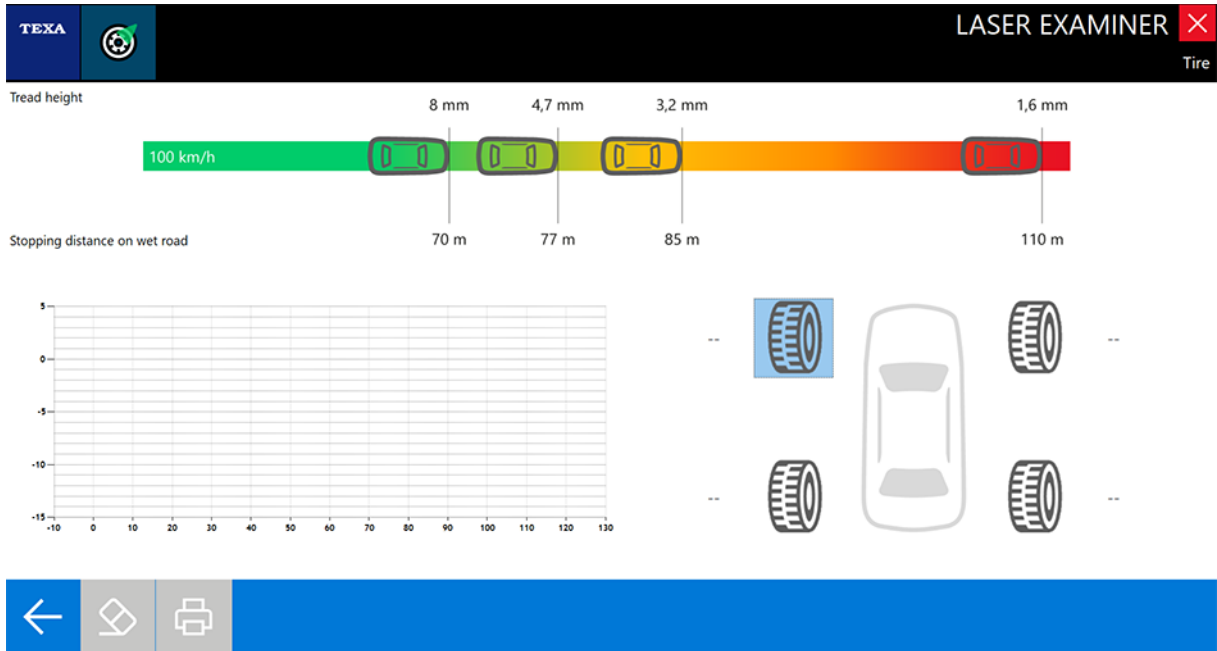

4. Position the tool on the tyre as indicated in the technical manual.
5. Press the power button to activate the laser.
6. Make sure the laser beam is perpendicular to the edge of the tread.
7. Make sure the laser beam does not pass over the tread wear indicators.
8. Press the power button to activate the micro-camera.

After the activation of the micro-camera, a beep indicates that the reading has been performed.





A second beep confirms that the data has been sent to the software correctly.

9. Proceed with the measurement on the other tyre treads.

The test result is displayed.



The measurement result is displayed graphically and the tyres are highlighted with a colour that indicates:

	Tyre tread depth not detected or waiting for measurement.
	The tyre tread depth is within the limits entered in the <i>Settings</i> menu.
	The tyre tread depth is close to the limit entered in the <i>Settings</i> menu.
	The tyre tread depth does not respect the limit entered in the <i>Settings</i> menu. We recommend replacing the tyre.

61.5 Multiple Measurements

The software allows you to perform from 1 to 5 acquisitions for each brake disc and each tyre. Set the number of acquisitions for disc testing and tyre testing in the *Settings* menu.

Proceed as follows:

1. Press: 
2. Select the desired value in the menus **Number of acquisitions for brake disc testing** and **Number of acquisitions for tyre testing**.

3. Press: 

4. Proceed with the acquisitions as indicated in the chapters **Brake disc**, **Fast Check** or **Tire**.
The calculated result is the arithmetic mean of the values acquired at the end of the measurements.

The software indicates each acquisition in the graph with a different colour.



61.6 Settings

This function allows you to configure the operating parameters for the software and the measuring tool.

NOTICE



The Settings menu screen appears automatically when the software is launched for the first time.

Proceed as follows:

1. Press: 

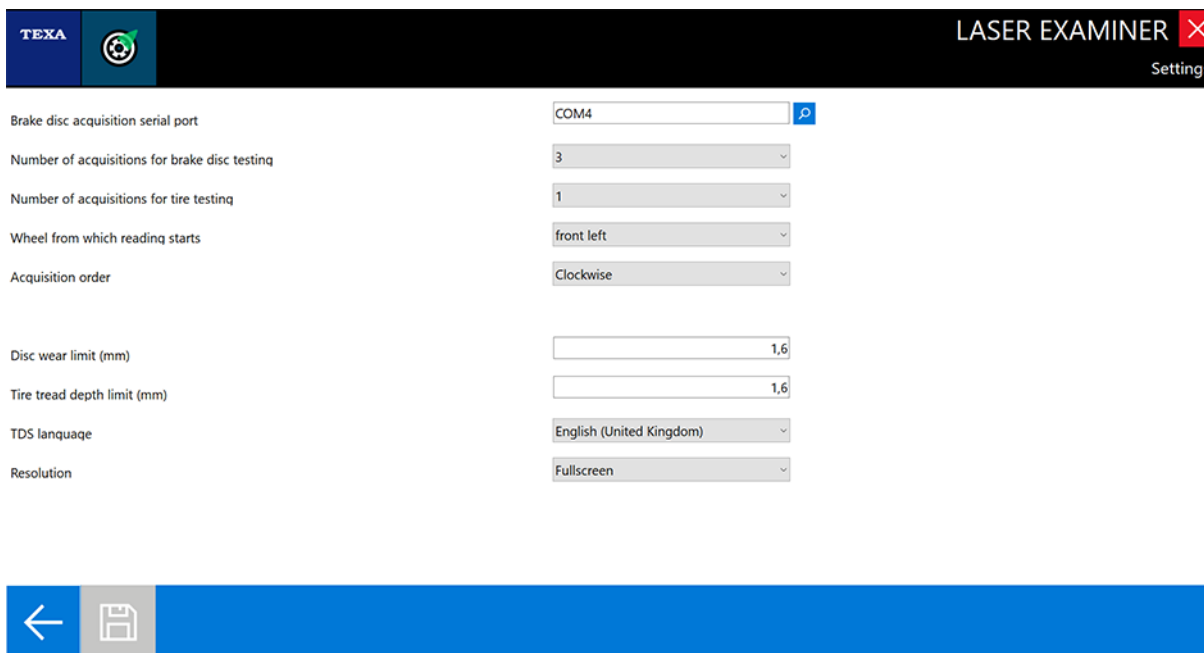
The screen is displayed.



Icon	Name	Description
	Back	It allows you to return to the previous page.
	Save	It allows you to save the entered data.

From the *Settings* menu you can configure:

- *Serial COM port.*
- *Number of acquisitions for brake disc testing (1 to 5).*
- *Number of acquisitions for tire testing (1 to 5).*
- *The wheel from which the software starts measuring.*
- *The wheel measuring order (clockwise or counterclockwise).*
- *Disc wear limit (mm).*
- *Tire tread depth limit (mm).*
- *The software user language.*
- *The screen resolution.*

61.6.1 Automatic configuration of the serial COM port

This function allows configuring the serial COM port automatically.

Proceed as follows:

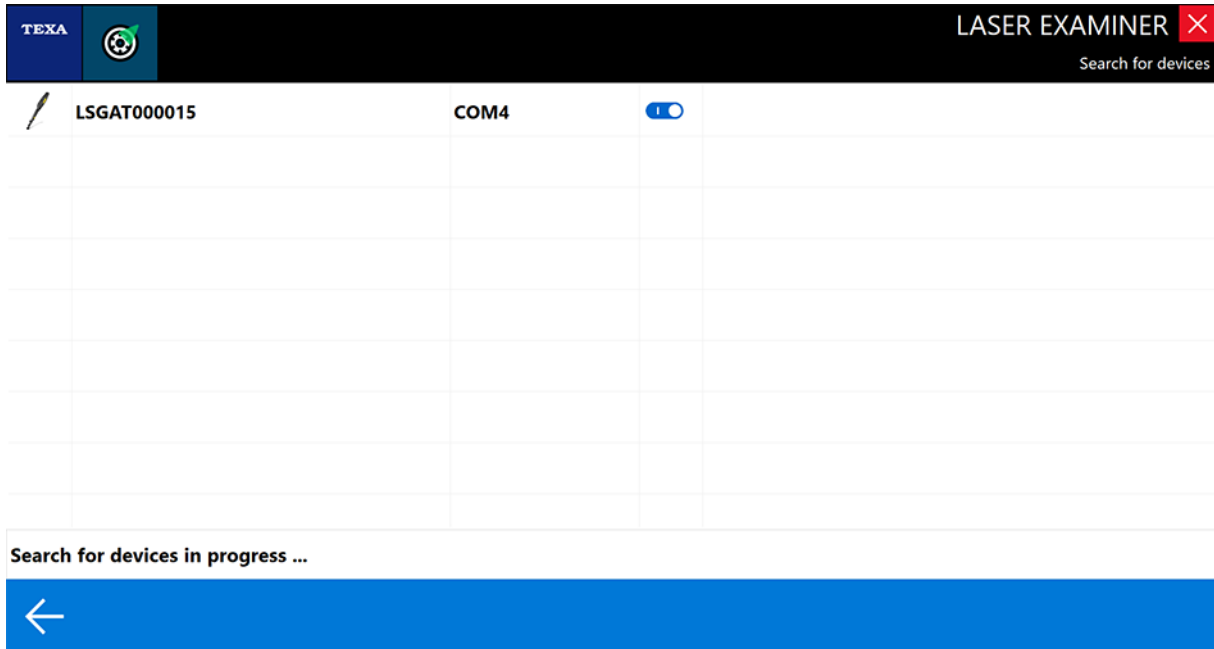

1. Press: 

The software displays the tools found during the scan.



In particular, it provides the following information:

- *type of tool;*
- *the tool's serial number;*
- *the associated COM port;*
- *status of the communication (active or not active).*

2. Activate / deactivate the tools through  / 

61.7 Workshop Data



This function allows you to enter the workshop information that will appear in the printed reports of the measurements carried out.

Proceed as follows:

1. Press: 
2. Enter the required information in the specific fields.

TEXA		LASER EXAMINER 	
		Workshop Data	
Officina PROVA			
Via Vallio	15	31050	TV
Monastier di Treviso	Italia		
0422791311	1234567890	Fax number	
officinaprova@gmail.com			



Icon	Name	Description
	Back	It allows you to return to the previous page.
	Save	It allows you to save the entered data.

61.8 Periodical Checks

This function allows you to carry out periodical checks on the measuring tool.

The function starts a procedure that guides operators step by step during all the operations required.

Proceed as follows:

1. Turn on the tool.
2. Connect the tool to the display unit via USB.

3. Press: 

The guided procedure is started.



Position the selected device onto the verification template and press NEXT.



4. Follow the instructions that appear on screen.

INFORMATION

Use the check rig provided with the tool in order to complete the check procedure successfully.

61.9 Firmware Update

This function allows you to update the firmware version of the measuring tool.

The function starts a procedure that guides operators step by step during all the operations required.

Proceed as follows:

1. Press: 

The guided procedure is started.



Position the selected device onto the verification template and press NEXT.



2. Follow the instructions that appear on screen.

61.11 Print / Export report

The measurement reports can be printed and exported.

Proceed as follows:

1. Select the report to print and/or export.

2. Press: 



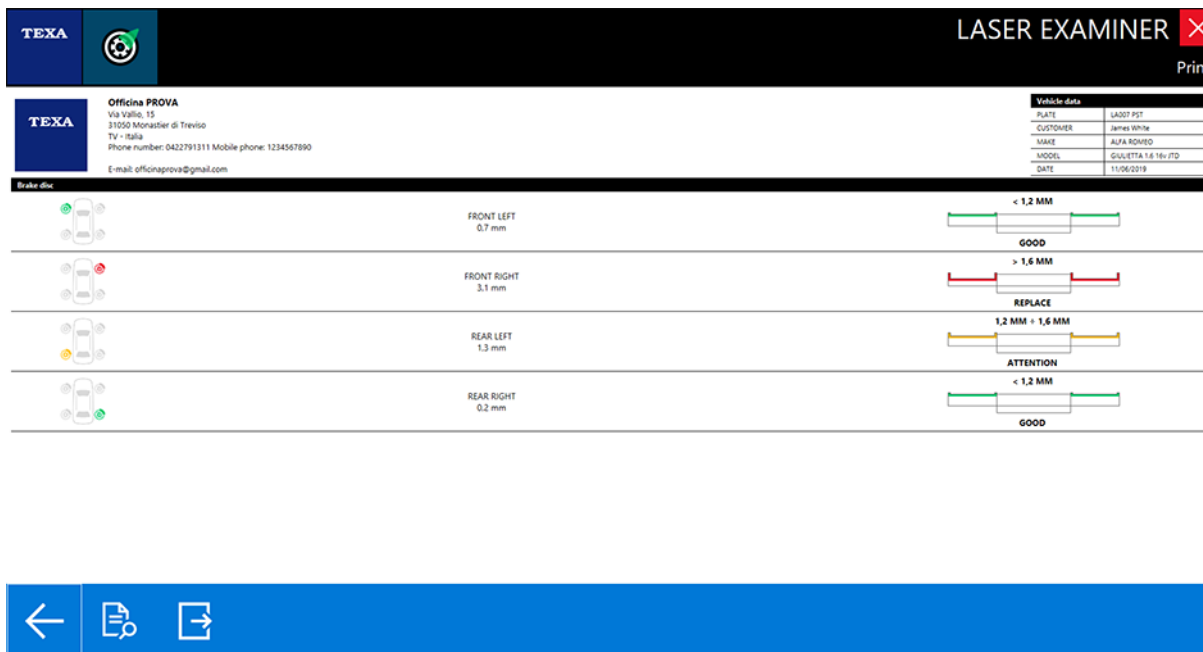

The report is displayed.





The screenshot displays the LASER EXAMINER software interface. At the top, there is a header with the TEXA logo, a circular icon, and the text "LASER EXAMINER" with a red "X" icon and a "Print" button. Below the header, there is a section for "Officina PROVA" with contact information: Via Vallo, 15, 31050 Monastier di Treviso, TV - Italia, Phone number: 0422791311, Mobile phone: 1234567890, and E-mail: officinaprova@gmail.com. To the right, there is a "Vehicle data" table:

Vehicle data	
PLATE	LA007 PST
CUSTOMER	James White
MAKE	ALFA ROMEO
MODEL	GIULETTA 16 16v JTD
DATE	11/06/2018

Below the vehicle data, there is a table showing brake disc measurements:

Brake disc	Measurement	Limit	Status
	FRONT LEFT 0,7 mm	< 1,2 MM	GOOD
	FRONT RIGHT 3,1 mm	> 1,6 MM	REPLACE
	REAR LEFT 1,3 mm	1,2 MM - 1,6 MM	ATTENTION
	REAR RIGHT 0,2 mm	< 1,2 MM	GOOD

At the bottom of the interface, there is a blue bar with three icons: a left arrow, a print icon, and an export icon.

Icon	Name	Description
	Back	It allows you to return to the previous page.
	Print preview	It allows viewing a print report regarding the test run.
	Export	It allows you to export the report of the measurement carried out in XML format.

62 HEADLIGHT ADJUST



Headlight Adjust is a software that allows the photometric analysis of the light beam projected by a vehicle headlight through use of a specific tool: the headlight tester.

Photometry is the set of techniques used to measure light-related quantities.

Photometric quantities such as the quantity of light, illuminance, luminance, etc. are used in optics to identify the characteristics of a light radiation beam and its effects on the human eye.

The tool allows you to ensure the proper distribution of the light beam and to adjust the headlights rigorously and in compliance with the regulations.

INFORMATION

This application is provided with a separate installation from the IDC6 one.

In order for the software to start properly, it must be activated using the specific code.

The activation through the code is carried out automatically the first time the software is started, if the tool is connected to an active Wi-Fi network.

For further information, contact your retailer.

62.1 Glossary

Operator: a qualified person responsible for using the testing tool.

Tool: any **eLight ONE** / **eLight ONE^D** headlight tester.

Headlamp: lighting device installed in a vehicle, composed of a light source (headlight) enclosed in a protective casing.

Headlight: single light source in the headlamp. It can be a low beam light, high beam light and fog light.

Yaw Angle: in the automotive industry, it is the angle α between the cut-off line rising from the inflection point and the horizontal line for asymmetric headlamps.

In aeronautics, it is the rotation of a vehicle around its vertical axis through the centre of gravity.

Rolling Angle: in the automotive industry, it is the angle β between the cut-off line and the horizontal line opposite the driving direction.

In aeronautics, it is the rotation of a vehicle around its longitudinal axis.

Cut-off line: limit between light area and dark area in low beams and fog lights.

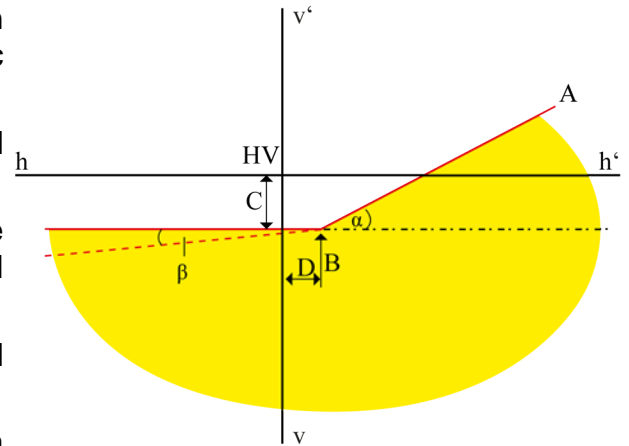

Hotspot: centre of the light beam in high beam headlights.

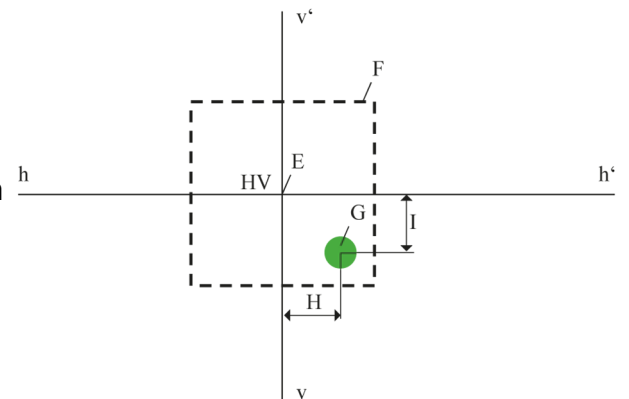

62.2 First start-up of eLight ONE^D

The tool **eLight ONE^D** is designed to work stand-alone, i.e. it can carry out the photometric analysis autonomously without needing to be connected to a display unit.

eLight ONE^D has a 7" touchscreen display with adjustable bracket, installed on the optical box.

The first time the tool is turned on, it must be activated and configured properly.

The configuration is carried out automatically the first time the software is started, if the tool is connected to an active Wi-Fi network.

Proceed as follows:

1. Select the software user language.

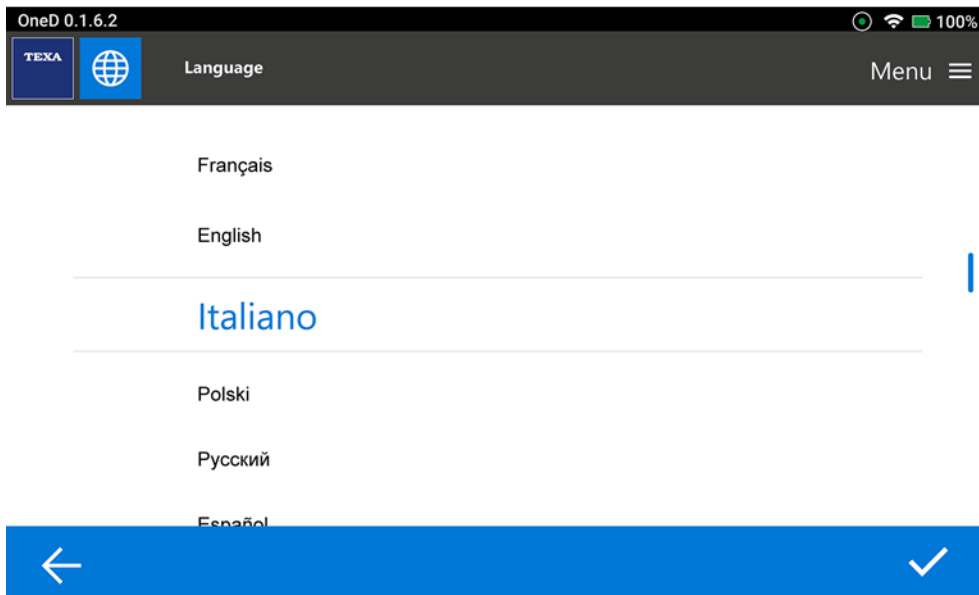

2. Press .

3. Select the Wi-Fi network you wish to connect the tool to.

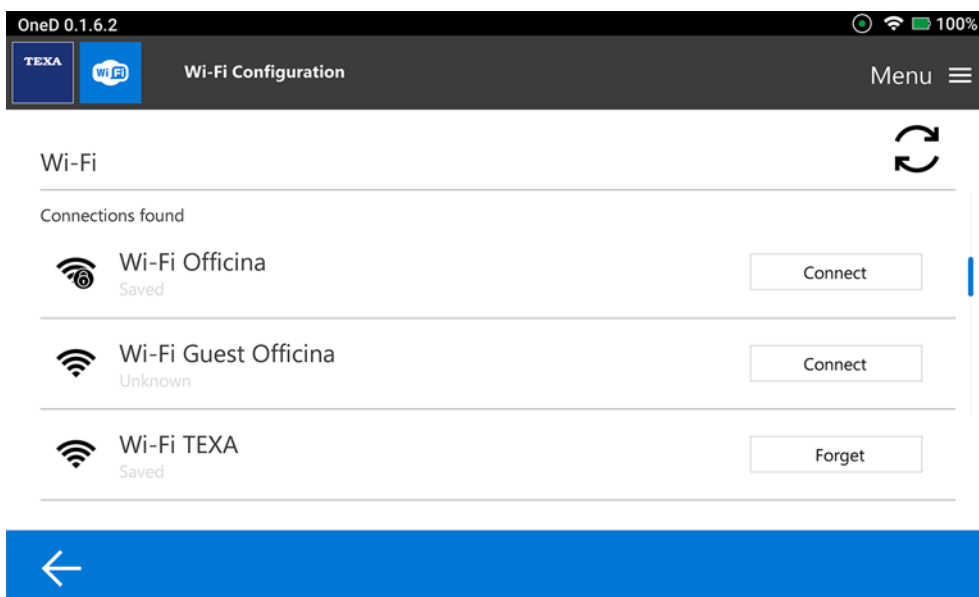

- 4.Press CONNECT.
- 5.Enter the password.
- 6.Press CONNECT.

For further information see the Wi-Fi chapter.

- 7.Activate the **LIGHT TEST** license.

For further information see the Software activation procedure chapter.

- 8.Enter the workshop information.

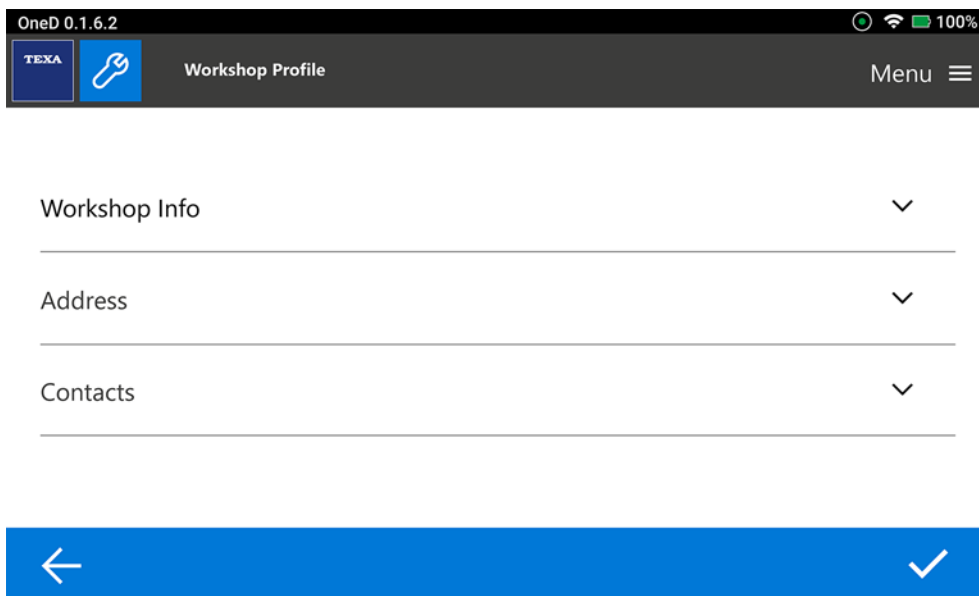

The **Light Geometry** screen is displayed.

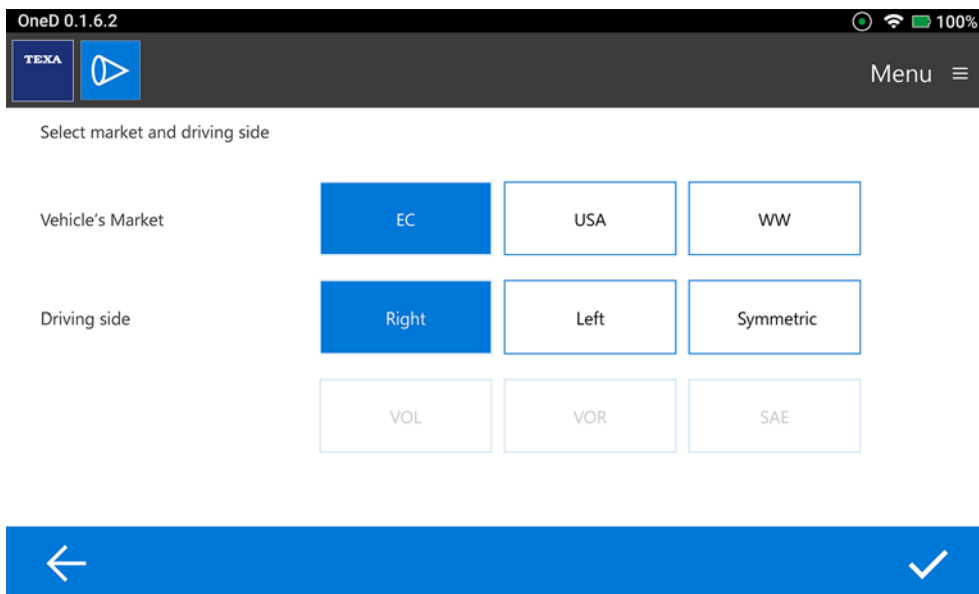

62.3 First start-up of eLight ONE

The connection between the tool and display unit is established via Wi-Fi.

INFORMATION

Make sure the display unit is equipped with a Wi-Fi card.

Make sure the display unit is properly connected to the company's Wi-Fi network.

The first time the tool is turned on, it must be activated and configured properly.

Proceed as follows:

1. Press: 
2. Follow the instructions that appear on screen.
3. Select and enable the tool that must be configured.

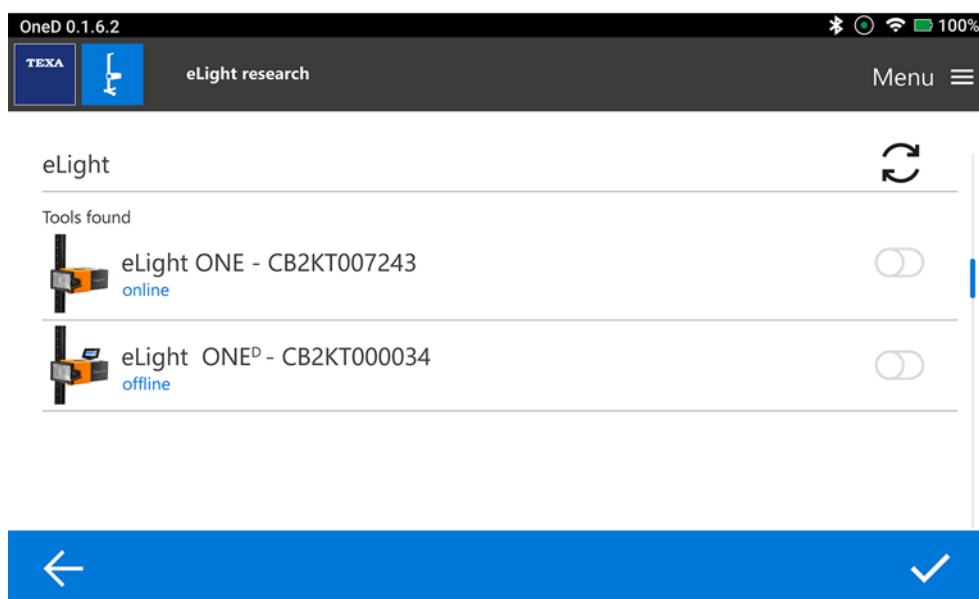

4. Press 
5. Select the software user language.

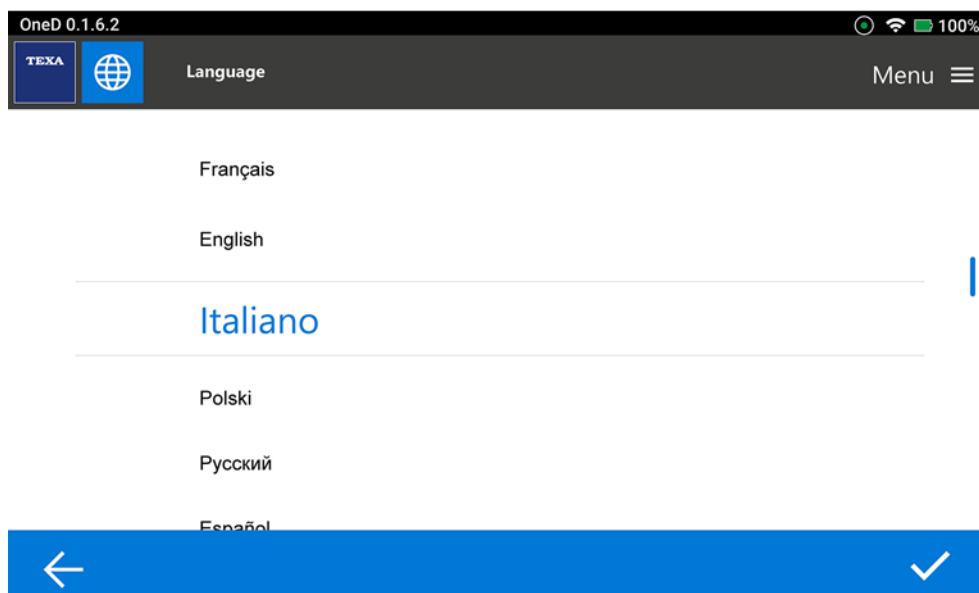

6. Press 

7. Select the Wi-Fi network you wish to connect the tool to.

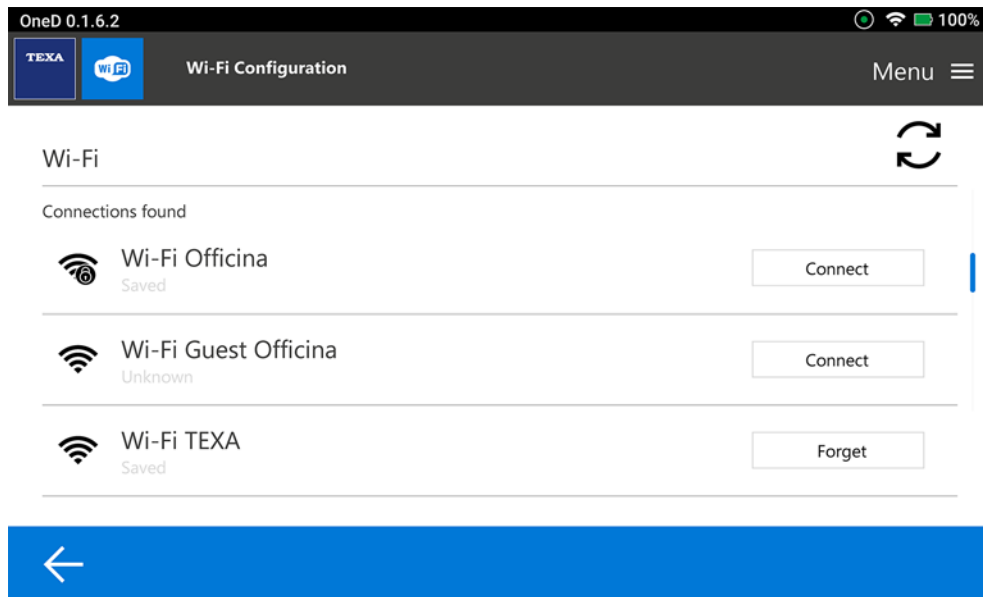

8. Press CONNECT.

9. Enter the password.

10. Press CONNECT.

For further information see the Wi-Fi chapter.

INFORMATION

If the Wi-Fi connection settings in the tool are changed, repeat the first start-up procedure.

11. Activate the **LIGHT TEST** license.

For further information see the Software activation procedure chapter.

62.4 Software activation

At the first start-up, the **LIGHT TEST** and **DIAG TEST** software is locked.

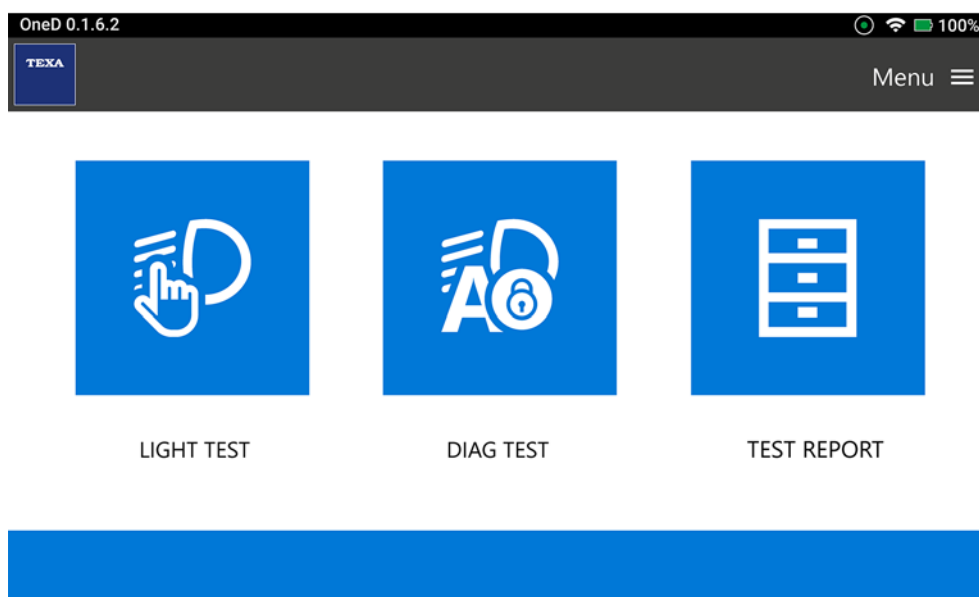

The two software programs must be activated separately.

LIGHT TEST

To activate the **LIGHT TEST** software, proceed as follows:

1. Press



INFORMATION

The activation through the entering of the activation code is carried out automatically the first time the tool is started, if the tool is connected to an active Wi-Fi network.

Otherwise, you will have to enter the code in the Confirmation Code section.

In order to know your activation code, contact your distributor.

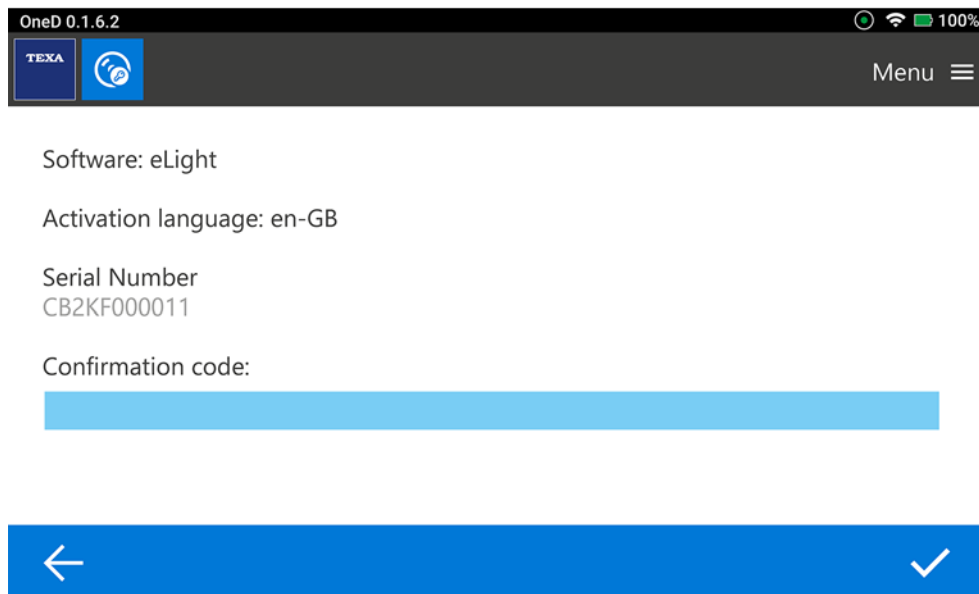

2. If the tool is connected to an active Wi-Fi, press



3. If the tool is NOT connected to an active Wi-Fi, enter the activation code in the Confirmation

Code section and press

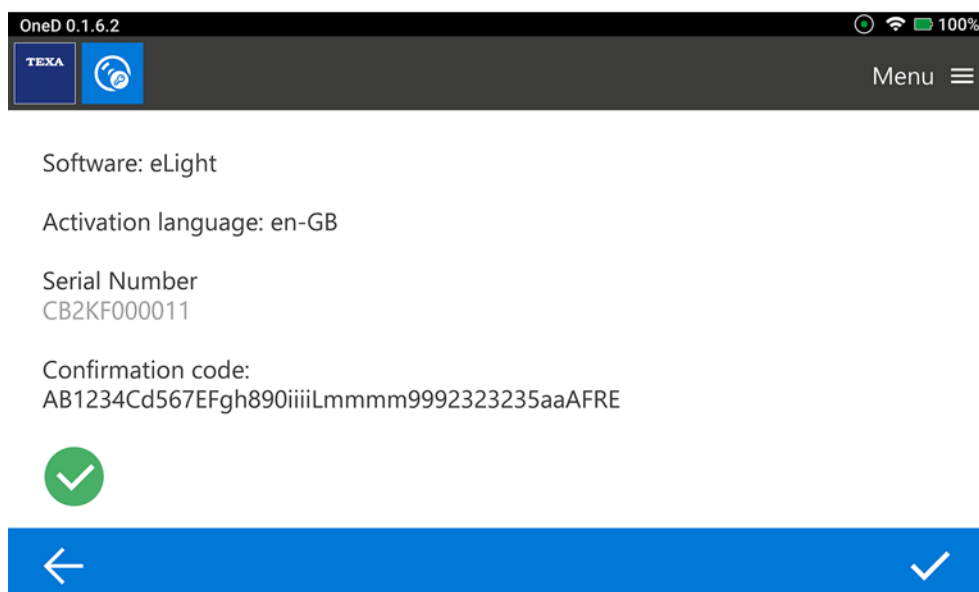

The **LIGHT TEST** software is activated.

4.To proceed, press .

5.Enter the workshop information.

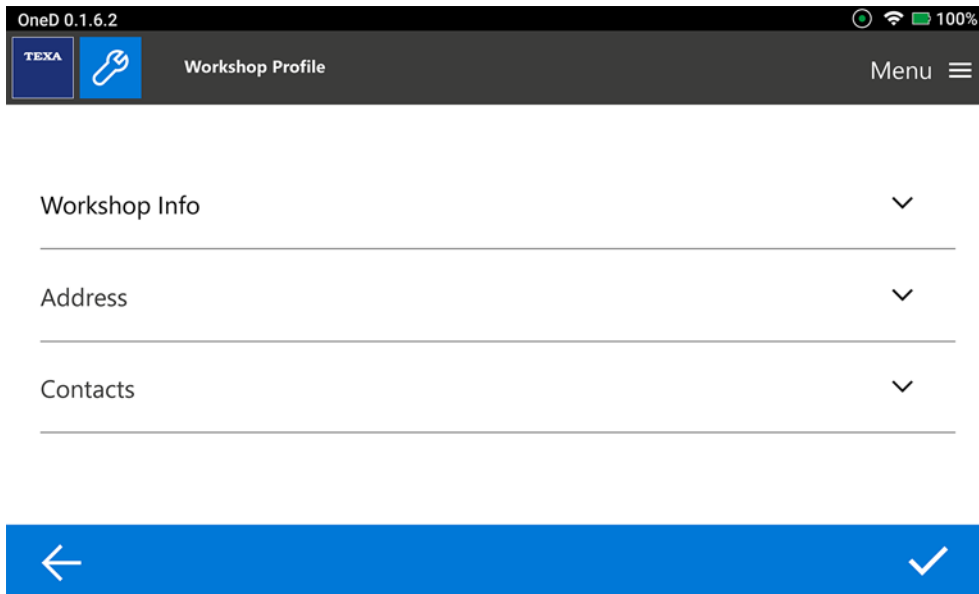

The **Light Geometry** screen is displayed.

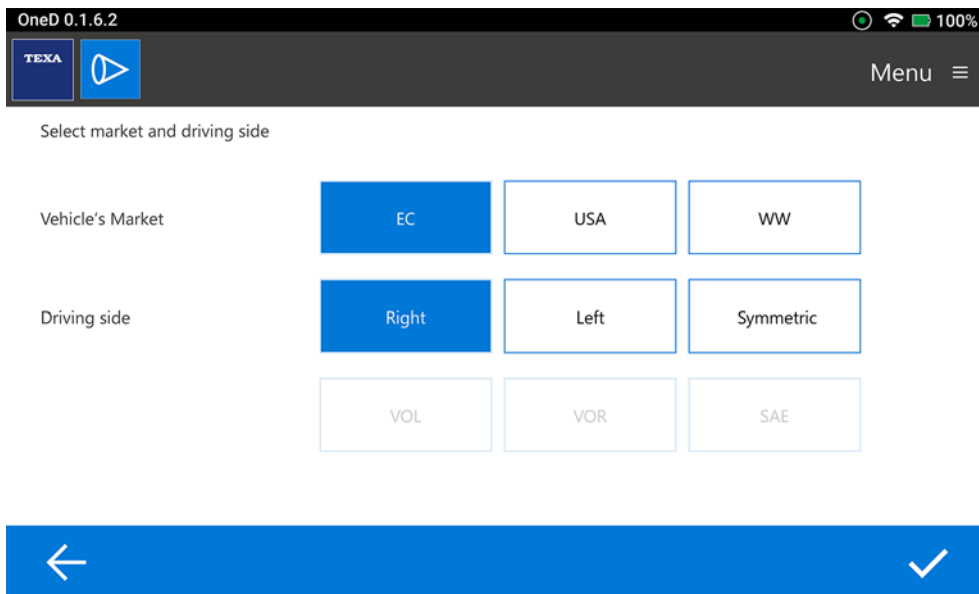

DIAG TEST

To unlock the **DIAG TEST** software, proceed as follows:

1. Insert the Micro Hasp key provided with the software in one of the USB connectors on the tool.

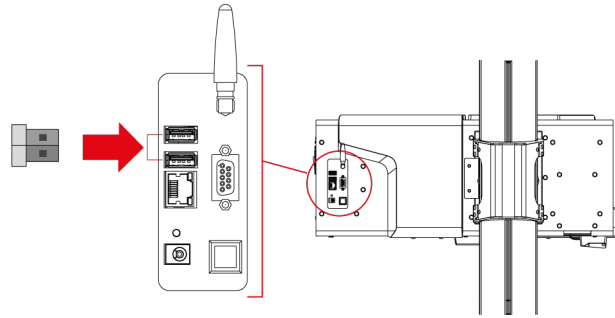

2. Press 

The software starts the tool code activation.

To activate the software you must accept the licenses and disclaimers.

3. Read the texts completely, scrolling the page using the vertical scroll bar.

4. Tick all the ACCEPT boxes.

5. Press 

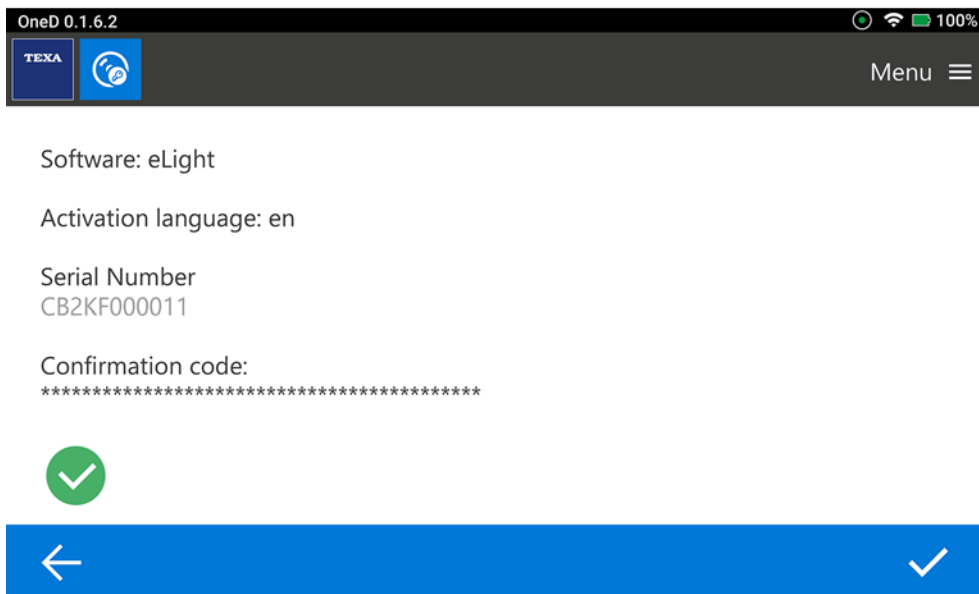

INFORMATION

The activation through the Countercode is carried out automatically the first time the tool is started, if the tool is connected to an active Wi-Fi network.

In order to know your Countercode, contact your distributor.

6. To proceed, press .

The **DIAG TEST** software is activated.

7. Select and enable the diagnostic tool that must be configured, if not already configured.

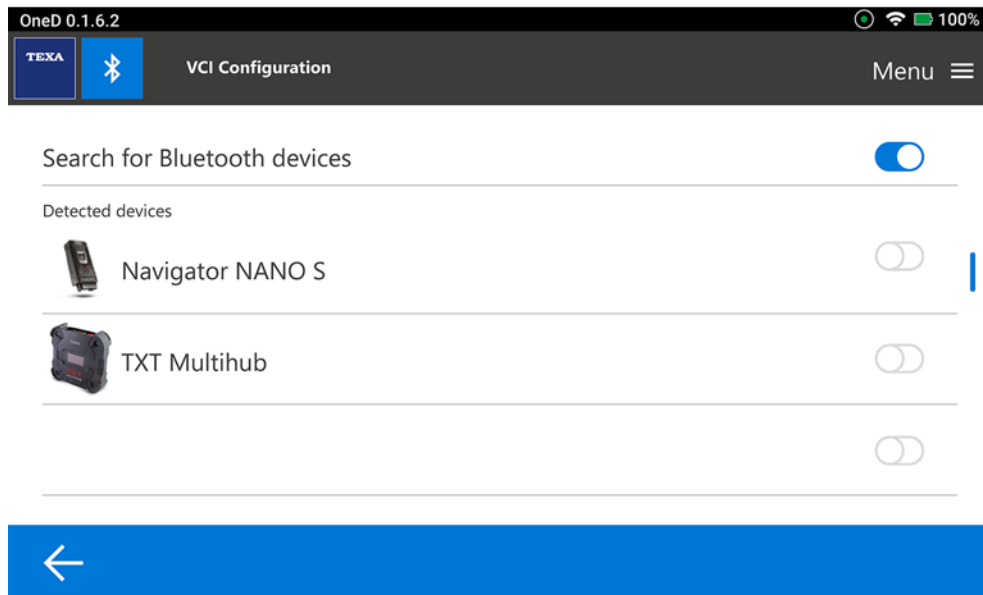

8. Follow the indications that appear on screen.

Wait for the configuration to complete.

62.5 HOME - HEADLIGHT ADJUST

The **HOME** screen allows you to launch the functions available in the software.

The image below is the software **HOME** screen.

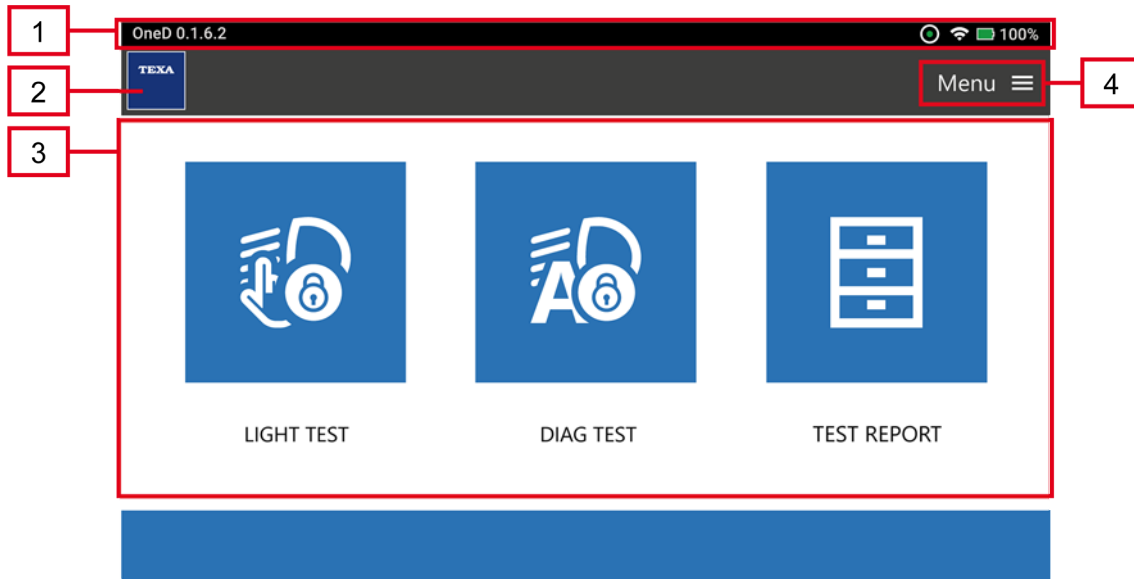

The screen is divided into:









1. *Status bar*
2. *HOME*
3. *Functions*
4. *Menu*

62.5.1 Status bar

The **Status Bar** displays:

- *information on the tool status;*
- *information on the software version;*
- *the date of use;*
- *the time of use.*

In particular, the icons indicate the following:



Icon	Name	Description
	Digital inclinometer	The tool is within the limits in which the digital inclinometer can correct the levelling.
	Digital inclinometer	The tool is NOT within the limits in which the digital inclinometer can correct the levelling. For further information, see the tool's Technical Manual.
	Wi-Fi connection	The tool is connected to the Wi-Fi network.
	Wi-Fi connection	The tool is NOT connected to the Wi-Fi network. For more information see the Settings chapter.
	Bluetooth connection	The tool is connected via Bluetooth communication.
	Bluetooth connection	The tool is NOT connected via Bluetooth communication. For more information see the Settings chapter.
	Battery	The battery level is indicated in percentage. For further information, see the tool's Technical Manual.
	Charging battery	The tool is connected to the mains.

62.5.2 Home

You can go back to the HOME screen by pressing the TEXA logo at any time.





62.5.3 Functions

The icons within this menu allow you to access the available functions.

Icon	Name	Description
	LIGHT TEST	It allows carrying out a photometric analysis on a vehicle's headlights based on parameters manually set by the operator. For further information, see the chapter LIGHT TEST.
	DIAG TEST	It allows carrying out a photometric analysis on a vehicle's headlights by automatically identifying the type of technology and lighting. For further information, see the chapter DIAG TEST.
	TEST REPORT	It allows you to display the tests performed. For further information, see the chapter TEST REPORT.

62.5.4 Menu

The icons within the **Menu** allow you to access the available functions and settings.

Icon	Name	Description
	Settings	It allows you to configure the operating parameters for the software, measuring tool and diagnostic tools.
	Updates	It allows you to check for updates and download them.
	LIGHT TEST	It allows carrying out a photometric analysis on a vehicle's headlights based on parameters manually set by the operator. For further information, see the chapter LIGHT TEST.
	DIAG TEST	It allows carrying out a photometric analysis on a vehicle's headlights by automatically identifying the type of technology and lighting. For further information, see the chapter DIAG TEST.
	TEST REPORT	It allows you to display the tests performed. For further information, see the chapter TEST REPORT.

62.6 LIGHT TEST



This function allows carrying out a photometric analysis on a vehicle's headlights based on parameters manually set by the operator.

Proceed as follows:

1. Press 

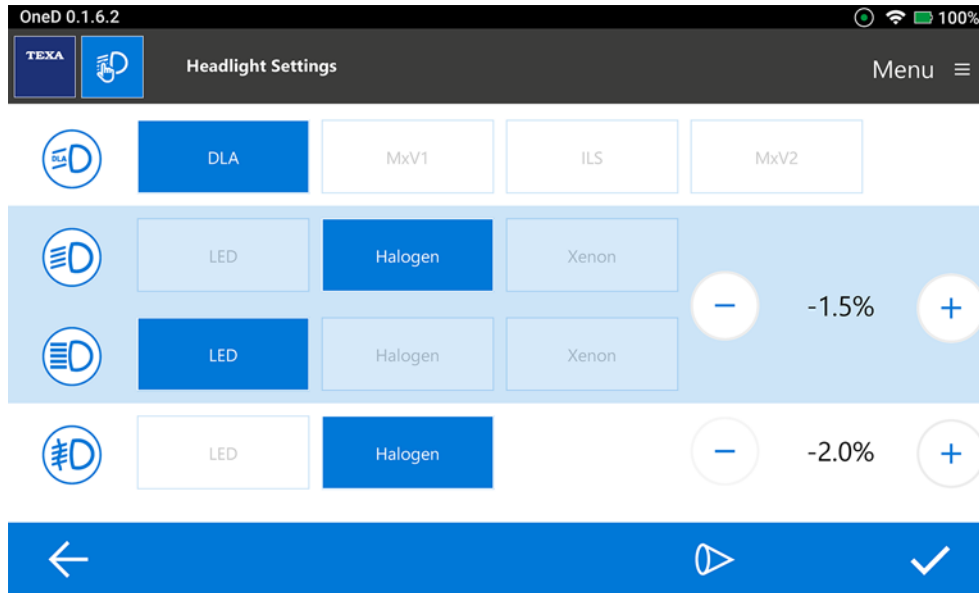
The **Headlight Settings** screen is displayed.



Icon	Name	Description
	Back	Allows you to return to the previous screen.
	Light Geometry	It allows you to temporarily change a vehicle's market and driving side. <i>For more information see the SETTINGS menu.</i>
	Confirm	It allows you to confirm the selections made.



2. Select the correct settings for the headlights of the vehicle to be tested, based on:

a) **type of technology**

The type of technology is based on the vehicle's equipment.





For further information, please refer to the technical documents provided by the vehicle manufacturer.

Icon	Description
	<p>Headlights with DLA (Dynamic Light Assist activation) system.</p> <p>The vehicles equipped with this system have a camera installed on the windscreen which analyses the preceding or oncoming vehicles.</p> <p>At speeds above 65 km/h, the system turns on the high beams permanently.</p> <p>As needed, the system automatically covers part of the headlights in order not to dazzle the preceding or oncoming vehicles.</p>
	<p>Headlights with system MATRIX (MxV1 / MxV2).</p> <p>The vehicles equipped with this system have a camera installed on the windscreen which analyses the preceding or oncoming vehicles.</p> <p>At speeds above 50 km/h, the system turns on the high beams permanently.</p> <p>As needed, the system turns on or off the light sources the headlight is made up of, in order not to dazzle the preceding or oncoming vehicles.</p> <p>The MATRIX system control unit can adjust the light beam intensity, adapting it to the various environmental conditions.</p>
	<p>Headlights with ILS (Intelligent Light System).</p> <p>It allows managing a vehicle's headlights, optimising their operation, varying the headlight intensity and tilt based on the type of road the vehicle is being driven on and the weather conditions.</p> <p>The system is also equipped with high beam assist, to avoid dazzling the preceding or oncoming vehicles, and dynamic cornering assist, which improves lighting and visibility.</p>



INFORMATION

Continuous technological evolutions may lead to the development of new settings and functions for the tool.



b) **type of headlight**

Icon	Description
	Low beam light
	High beam light
	Fog light

c) **type of lighting**

Icon	Description
	Headlight with LED light
	Headlight with halogen light
	Headlight with Xenon light

d) **nominal headlight tilt**

Icon	Description
	<p>It allows you to set the nominal tilt based on the value specified by the headlight manufacturer.</p> <p>For further information, please refer to the technical documents provided by the vehicle manufacturer.</p> <p>When the icon is pressed, the value decreases.</p> <p>The tilt is expressed as a percentage (%).</p>
	<p>It allows you to set the nominal tilt based on the value specified by the headlight manufacturer.</p> <p>For further information, please refer to the technical documents provided by the vehicle manufacturer.</p> <p>When the icon is pressed, the value increases.</p> <p>The tilt is expressed as a percentage (%).</p>

INFORMATION

The nominal tilt value prescribed by the manufacturer is printed on the headlight (example: ).

3. Confirm the selection



Follow the indications that appear on screen.

The **Photometric Analysis** screen is displayed.

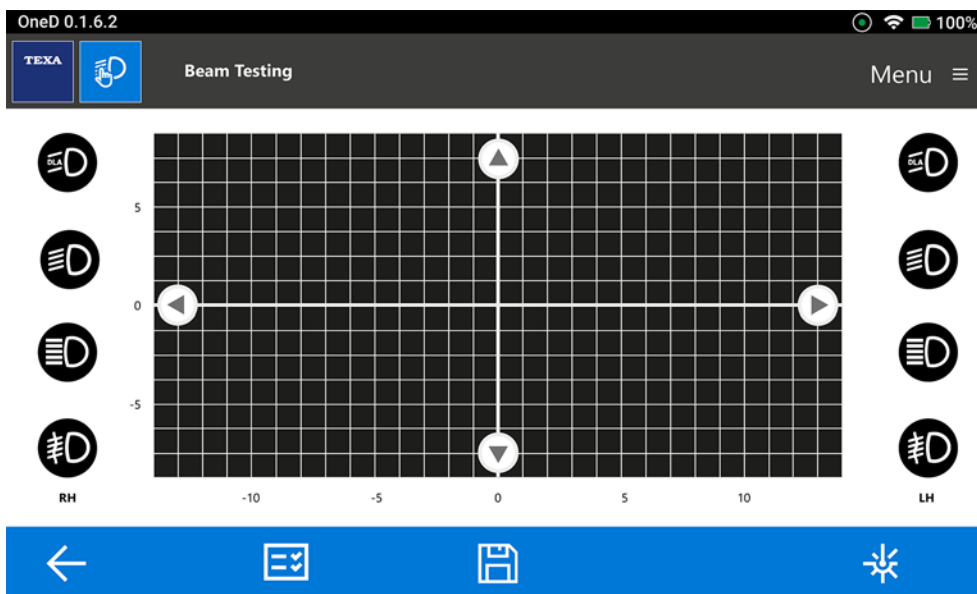

For further information see the **Photometric Analysis** chapter.

62.7 DIAG TEST

This function allows carrying out a photometric analysis on a vehicle's headlamps by automatically identifying the type of technology and lighting.

NOTICE

Make sure the diagnostic tool has been configured correctly.

For further information see the Settings chapter.

Make sure the Wi-Fi network has been configured correctly.

For further information see the Settings chapter.

Proceed as follows:

1. Press 

2. Select the category for which you wish to access the diagnostic functions.

The selection is made by choosing among the options in the drop-down menus.

In order to go from one selection level to the next you must first complete the level you are currently in.

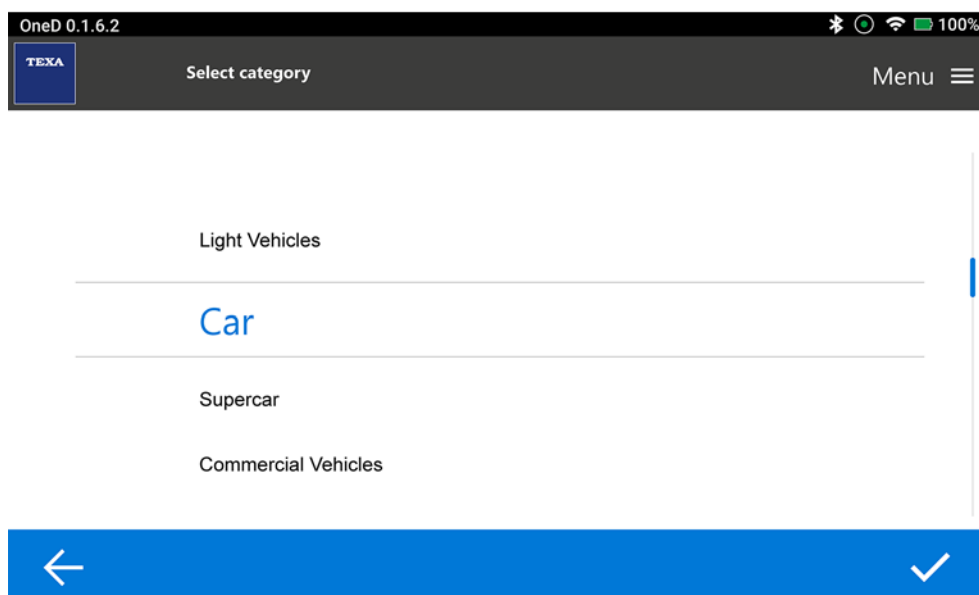

Icon	Name	Description
	Back	Allows you to return to the previous screen.

4. After identifying the vehicle **Make**, you can choose the type of selection:

- *Automatic*;
- *Manual*.

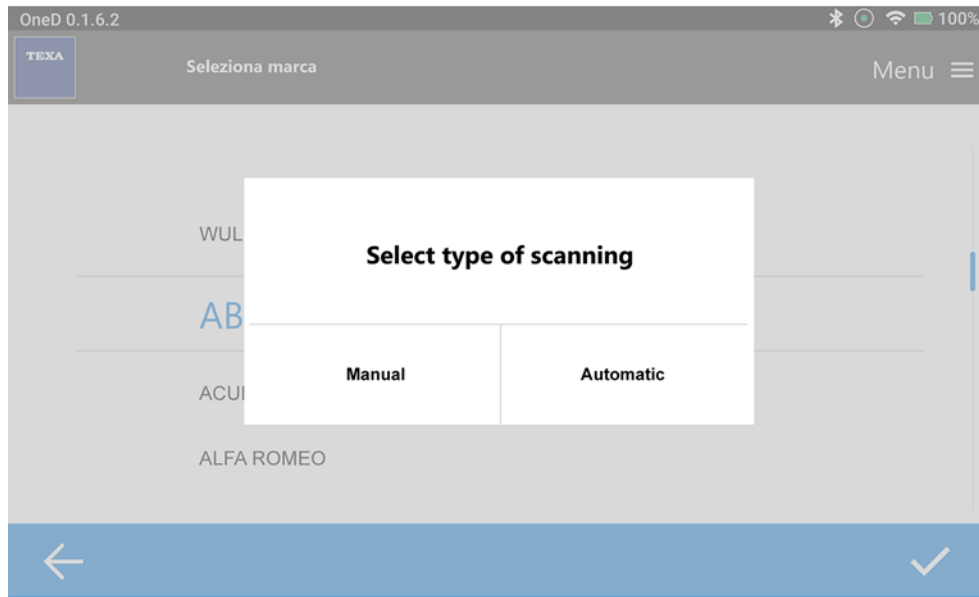

By pressing **Automatic**, the software automatically identifies the **Model** and **Model Variant**.

NOTICE

The diagnostic tool must be connected to the vehicle's diagnostic socket.

Follow the indications that appear on screen.

By pressing **Manual**, you must set the fields required for the vehicle selection manually.

Follow the indications that appear on screen.

Wait for the vehicle scan to complete.



7.If the scan is successful, the headlight type is set automatically.

In case of a negative result, the headlight type is set on **Halogen** by default.

The setting can be changed manually by pressing on the other options.

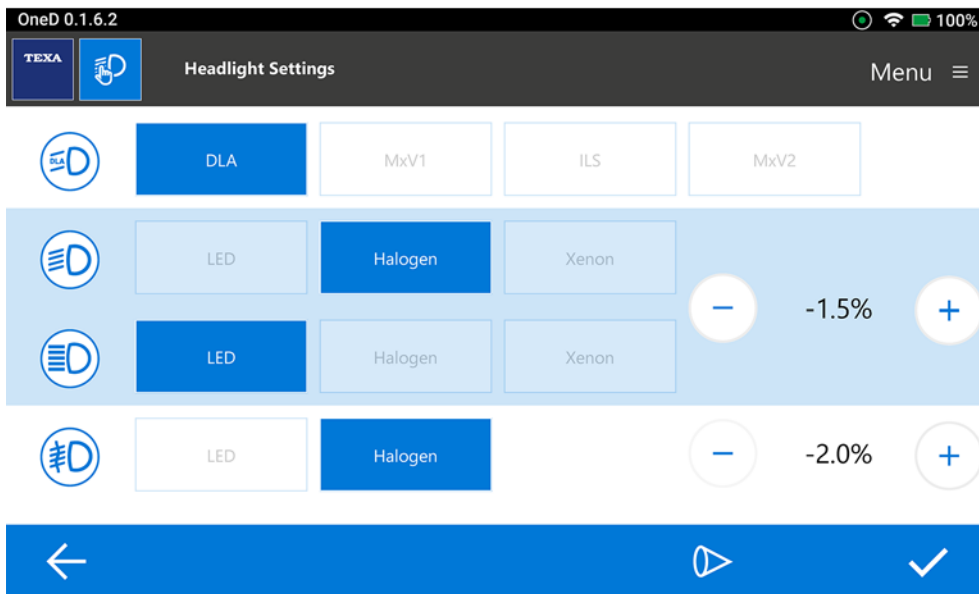
8.Set the nominal headlamp tilt.



Icon	Description
	It allows you to decrease the headlamp tilt. The tilt is expressed as a percentage (%). The tilt value prescribed by the manufacturer is indicated on the headlamp.
	It allows you to increase the headlamp tilt. The tilt is expressed as a percentage (%). The tilt value prescribed by the manufacturer is indicated on the headlamp.

The nominal tilt value prescribed by the manufacturer is printed on the headlamp (example:





The type of technology is based on the vehicle's equipment.





For further information, please refer to the technical documents provided by the vehicle manufacturer.

- **Headlight technology**

Icon	Description
	<p>Headlights with DLA (Dynamic Light Assist activation) system.</p> <p>The vehicles equipped with this system have a camera installed on the windscreen which analyses the preceding or oncoming vehicles.</p> <p>At speeds above 65 km/h, the system turns on the high beams permanently.</p> <p>As needed, the system automatically covers part of the headlights in order not to dazzle the preceding or oncoming vehicles.</p>
	<p>Headlights with system MATRIX (MxV1 / MxV2).</p> <p>The vehicles equipped with this system have a camera installed on the windscreen which analyses the preceding or oncoming vehicles.</p> <p>At speeds above 50 km/h, the system turns on the high beams permanently.</p> <p>As needed, the system turns on or off the light sources the headlight is made up of, in order not to dazzle the preceding or oncoming vehicles.</p> <p>The MATRIX system control unit can adjust the light beam intensity, adapting it to the various environmental conditions.</p>
	<p>Headlights with ILS (Intelligent Light System).</p> <p>It allows managing a vehicle's headlights, optimising their operation, varying the headlight intensity and tilt based on the type of road the vehicle is being driven on and the weather conditions.</p> <p>The system is also equipped with high beam assist, to avoid dazzling the preceding or oncoming vehicles, and dynamic cornering assist, which improves lighting and visibility.</p>

- **Type of headlight lighting**

Icon	Description
	Headlight with LED light
	Headlight with halogen light
	Headlight with Xenon light

3. Confirm the selection



Follow the indications that appear on screen.

The **Photometric Analysis** screen is displayed.

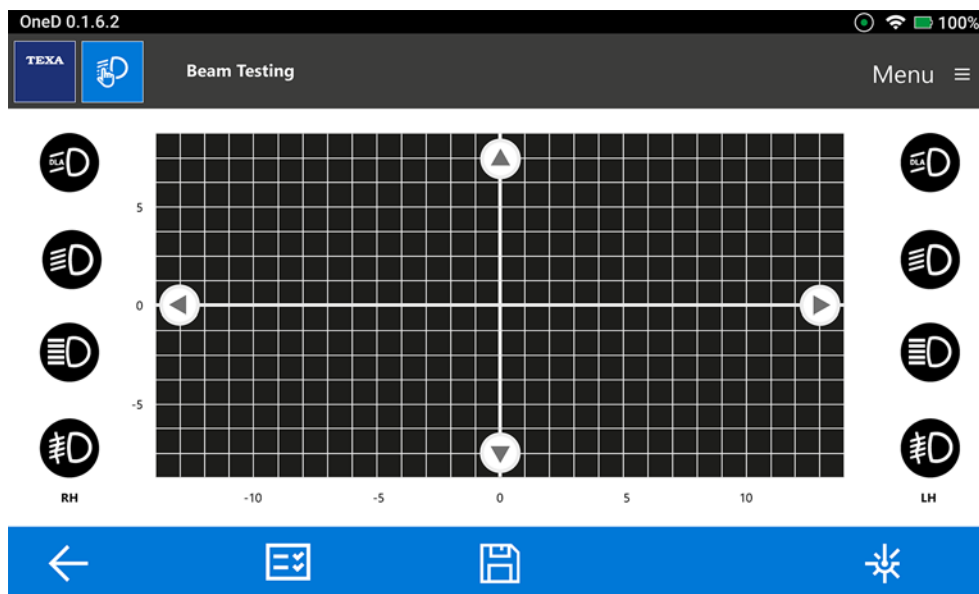

For further information see the **Photometric Analysis** chapter.

62.8 Photometric Analysis

The **Photometric Analysis** allows you to measure and assess the correct adjustment of the light beam of a vehicle's headlights.

NOTICE

Before proceeding with the analysis, make sure the tool has been positioned correctly.

The characteristics and conditions of the work surface, for both the vehicle and the tool, are essential for a correct headlight adjustment.



For further information, see the tool's technical manual.

Proceed as follows:

1. Position the tool in front of the vehicle as indicated in the Technical Manual.

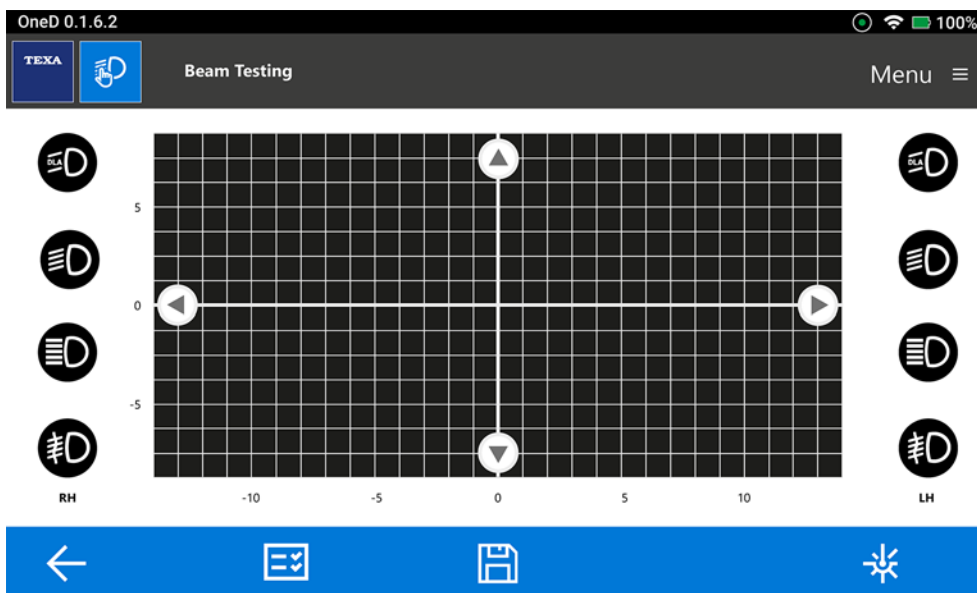

Icon	Name	Description
	Back	Allows you to return to the previous screen.
	Summary	It allows you to display a summary of the test performed.
	Save	It allows you to save the data of the test performed.
	Laser off	It indicates that the laser positioned under the optical box is off.
	Laser on	It indicates that the laser positioned under the optical box is on.

2. Press 

The lasers will turn on.

3. Centre the optical box as indicated in the tool's Technical Manual.

INFORMATION

The Fresnel lens within the tool's optical box makes it easier to use, as it rectifies any possible inaccuracies.













4. Turn on the vehicle's headlights.

Follow the indications that appear on screen.

5. Press 

The lasers will turn off.

6. Press the icon of the headlight (low beam, high beam, fog light) to be tested.

Low beams	High beams	Fog lights	Headlights with DLA system	Headlights with MATRIX system	Headlights with ILS system	Description
						Selectable headlight
						Selected headlight. Test in progress.

The headlight test is started.

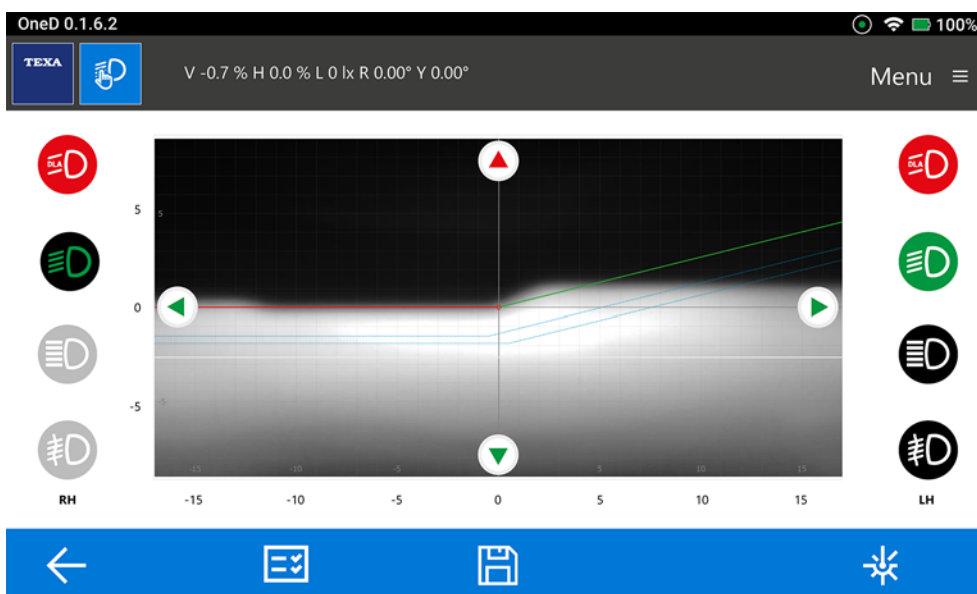

In the upper part of the screen, the test results are displayed in real time:

- Vertical beam tilt (%)
- Horizontal beam tilt (%)
- Luminous intensity (lx);
- Yaw angle (Y°);
- Roll angle (R°).

In the central part of the screen, the following is displayed:

	/	Dashed line	It indicates the upper and lower tolerance limits within which the headlight is considered to be adjusted properly.
		GREEN	It indicates that the measured value is within the set limits.
		RED	It indicates that the measured value is NOT within the set limits. It indicates in which direction the headlight must be adjusted in order to fall within the set limits.

7. Act on the screws placed on the headlamp to adjust the beam.

INFORMATION

The headlight is adjusted properly when the lines and arrows are coloured green.

The lines and arrows must be coloured green.

8. To complete the headlight's photometric analysis, press on the related symbol.

						Test completed successfully. The headlight can be selected for a new test.
						Test completed with a negative result. The headlight can be selected for a new test.

9. You can select a new headlight to analyse.

Move the tool in front of the headlight you wish to analyse.

10. The tests performed can be saved at any time, to have a complete report on the adjustments. Each report includes the headlight's photometric images and measured values.

For further information, see the paragraph **Storage of the tests performed.**

62.8.1 Storage of the tests performed

This function allows you to save and archive the tests performed.

Proceed as follows:

1. Press 

The **Edit Vehicle** screen is displayed.

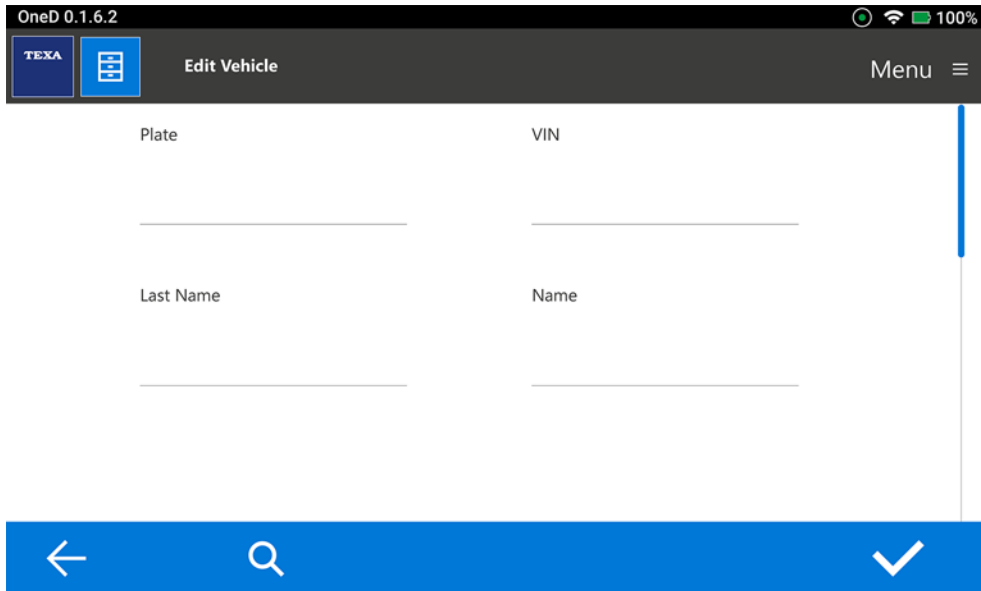

2. Enter the requested data, or at least the license plate number or the VIN.

3. Confirm 

Follow the indications that appear on screen.

INFORMATION

You cannot enter the data related to a customer without having entered the data of a vehicle first.

The stored tests can be displayed in the **TEST REPORT** or Summary menus.

For further information, see the chapter TEST REPORT.

62.9 TEST REPORT





This function allows you to display the reports of the tests performed and information on the vehicles previously stored.

Proceed as follows:

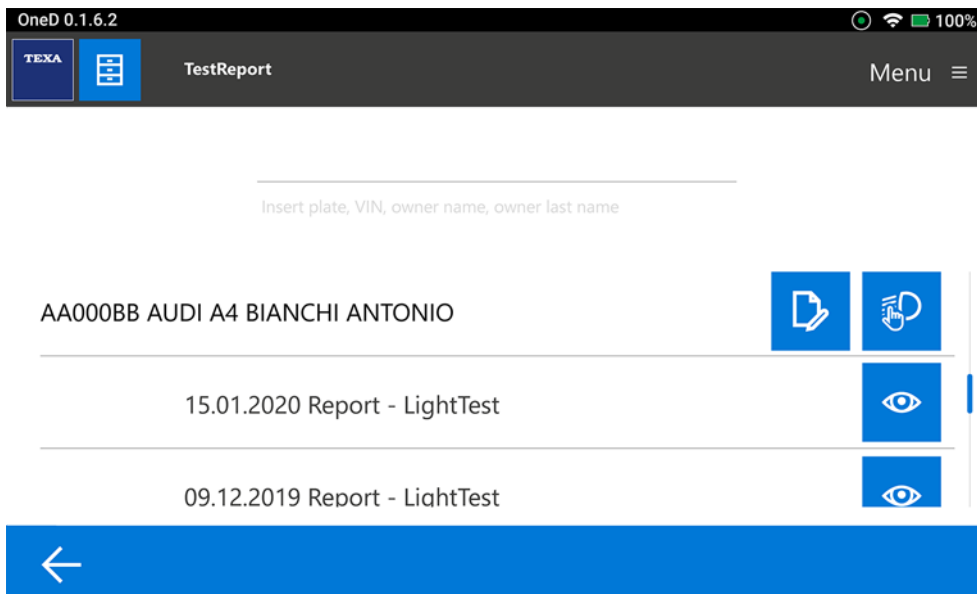
1. Press 

The **TEST REPORT** screen is displayed.



Icon	Name	Description
	Back	It allows you to return to the previous screen.
	Edit	It allows you to edit the vehicle's and/or owner's data.
	LIGHT TEST	It allows you to start a new photometric analysis. For further information, see the chapter LIGHT TEST.
	View	It allows you to view the diagnostic report.

2. Enter at least one of the following data:

- *licence plate number;*
- *VIN (Vehicle Identification Number);*
- *vehicle model;*
- *owner.*

As an alternative, scroll the list on the display or using the sidebar and select the required **TestReport**.

62.9.1 Test report reading



This page allows you to view the reports of the tests performed and the results obtained for the vehicle selected in the **TEST REPORT** menu.

Proceed as follows:





1. Press 

Below is an example of a test report:



Icon	Name	Description
	Back	Allows you to return to the previous screen.
	LIGHT TEST	It allows you to start a new analysis. For further information, see the chapter LIGHT TEST.
	Print	It allows you to print the report. For further information, see the TestReport Print / Export chapter.

The **Report** provides the following indications:

Icon	Name	Description
	Luminous intensity	It indicates the headlight's luminous intensity, expressed in lux (lx).
	Tilt	It indicates the vertical headlight tilt as a percentage.
	Deviation	It indicates the horizontal headlight tilt as a percentage.
	Asymmetry	It indicates the deviation angle of the low-beam light beam projected in the driving direction. It is also known as yaw angle (see glossary).
	Rotation	It indicates the deviation angle of the low-beam light beam projected in the opposite driving direction. It is also known as roll angle (see glossary).

62.9.2 Test report export / print

This function allows you to print the **TestReports** on a thermal printer or export them onto a **USB** drive.



Make sure the thermal printer is installed.

In order to print the report, proceed as follows:

1. Press 

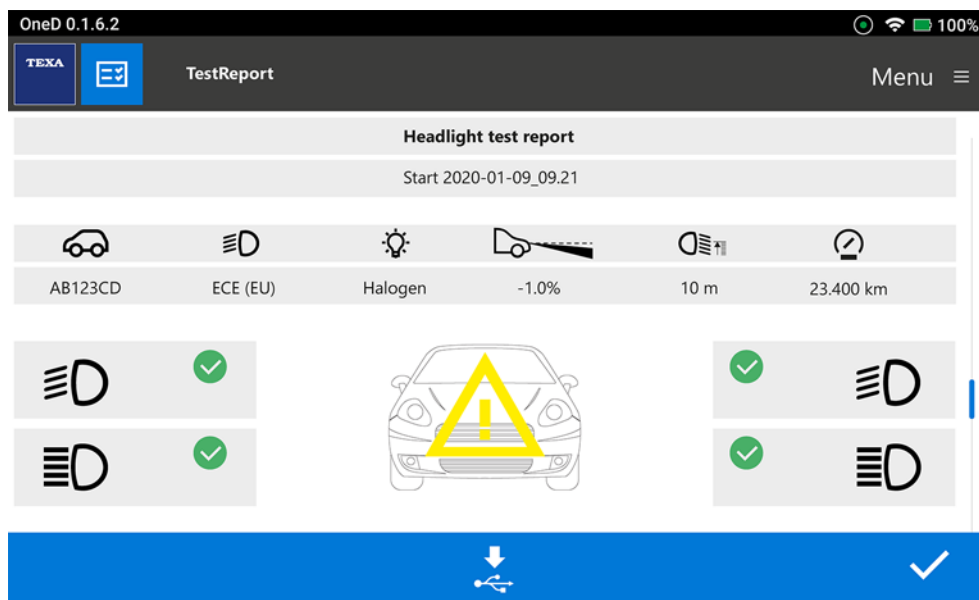
The Headlight test report is displayed for printing.





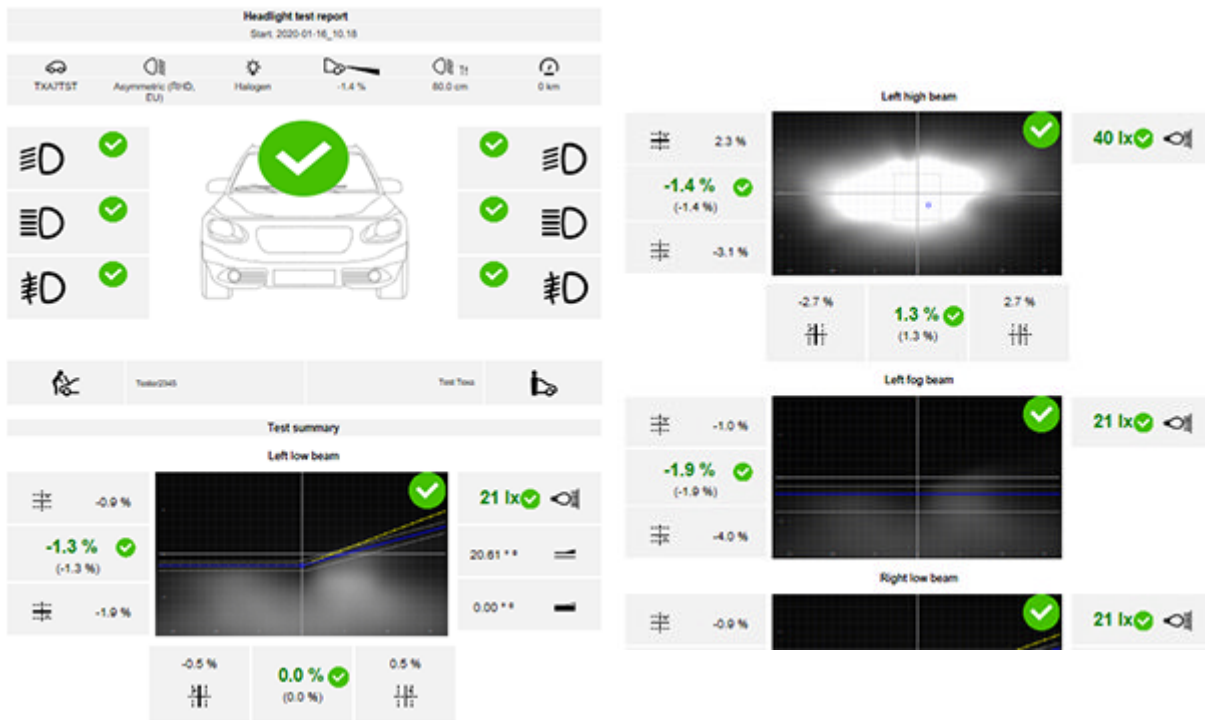

Icon	Name	Description
	USB export	It allows you to export the TestReport onto a USB drive. For the exact position of the USB ports available on the tool, see the Technical Manual.
	Print	It allows you to print the TestReport on the built-in thermal printer. The icon only appears if the thermal printer is installed.

Example of a complete Headlight test report.



Icon	Name	Description
	Plate	It indicates the vehicle's license plate number.
	Vehicle's Market	It indicates the vehicle's market (Europe, United States, or Worldwide).
	Lighting	It indicates the type of lighting (LED, Halogen or Xenon).
	Nominal tilt	It indicates the tilt value specified by the manufacturer.
	Beam height	It indicates the headlight's height detected by the tool.
	Low beam light	It indicates whether the status of the low beam headlight is correct or not.
	High beam light	It indicates whether the status of the high beam headlight is correct or not.
	Workshop operator	It indicates the workshop operator's name that was entered when saving the data.
	Owner	It indicates the vehicle owner's name that was entered when saving the data.
	Vertical tilt	It indicates the percentage of upper vertical tilt with respect to the headlight's centre.
	Vertical tilt	It indicates the percentage of lower vertical tilt with respect to the headlight's centre.





	Horizontal deviation	It indicates the percentage of horizontal tilt to the right with respect to the headlight's centre.
	Horizontal deviation	It indicates the percentage of horizontal tilt to the left with respect to the headlight's centre.
	Asymmetry	It indicates the deviation angle of the low-beam light beam projected in the driving direction.
	Rotation	It indicates the deviation angle of the low-beam light beam projected in the opposite driving direction.
	Luminous intensity	It indicates the headlight's luminous intensity, expressed in lux (lx).

62.10 MENU

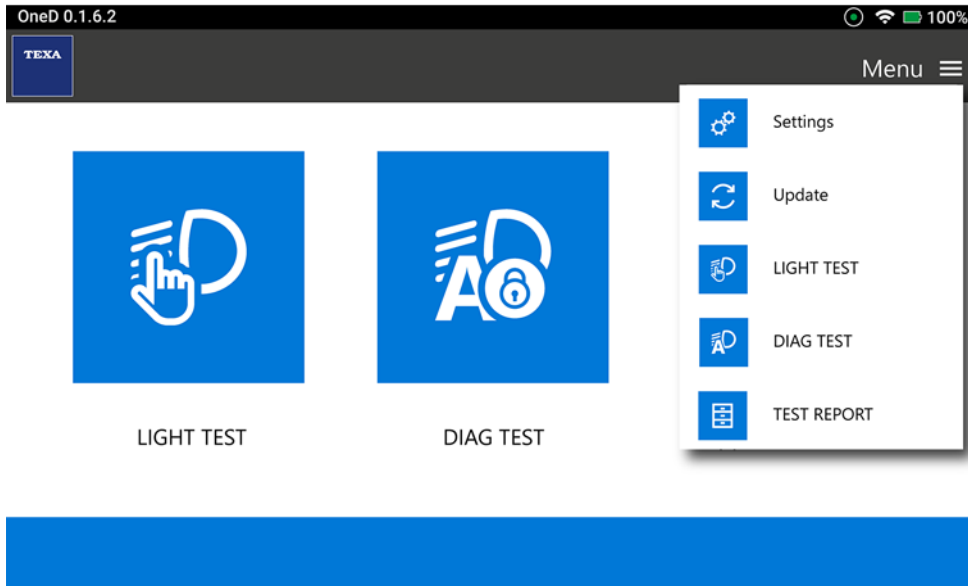
The icons within the **Menu** allow you to access the available functions and settings. Proceed as follows:

1. Press 



Icon	Name	Description
	Settings	It allows you to configure the operating parameters for the software, measuring tool and diagnostic tools.
	Updates	It allows you to check for updates and download them.
	LIGHT TEST	It allows carrying out a photometric analysis on a vehicle's headlights based on parameters manually set by the operator.
	DIAG TEST	It allows carrying out a photometric analysis on a vehicle's headlamps by automatically identifying the type of technology and lighting.
	TEST REPORT	It allows you to display the tests performed.

62.10.1 Settings

This menu allows you to access the software configurations, such as:









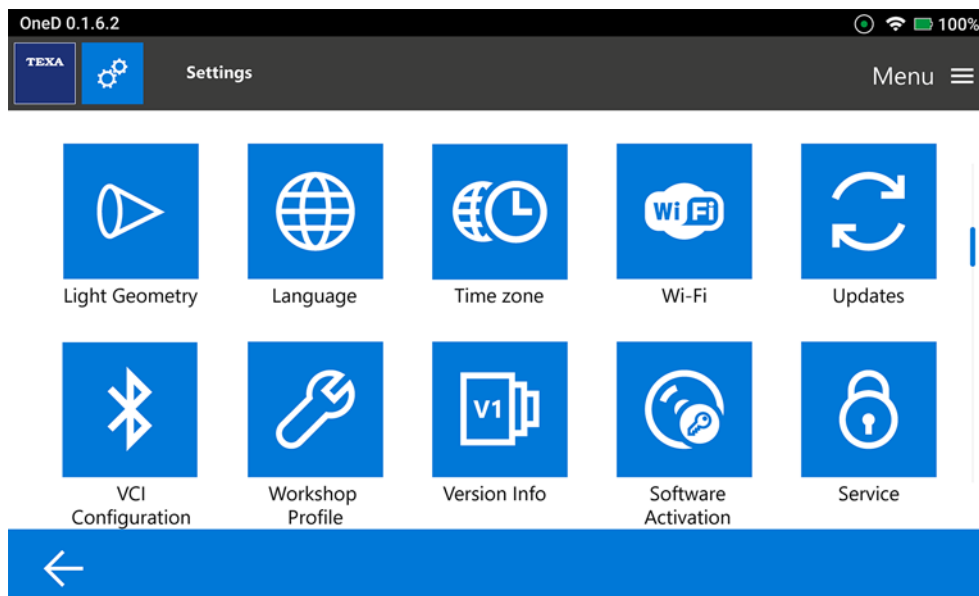

- *the user language selection;*
- *the software activation;*
- *the workshop profile;*
- *the configuration of the diagnostic VCI;*
- *etc.*

Proceed as follows:

1. Press 

The **Settings** menu is displayed.



Icon	Name	Description
	Light Geometry	It allows you to select the type of market and driving side of a vehicle for each photometric analysis.
	Language	Allows you to change the language in which the software is displayed.
	Time Zone	It allows you to set the date and time for the country or zone where the tool is used.
	Wi-Fi	It allows you to configure the Wi-Fi network.
	Updates	It allows you to check for updates and download them.
	VCI Configuration	It allows you to configure the diagnostic devices.
	Workshop Profile	It allows you to set the workshop information.
	Version Info	It provides information on the software version.
	Software Activation	It allows you to activate the software.
	Service menu	Allows you to access the customer service functions. These functions must be used only if indicated to do so by the Technical Assistance.

LIGHT GEOMETRY

This menu allows you to select the type of market and driving side of a vehicle for each photometric analysis.



The selection can be temporarily changed before each photometric analysis.

Proceed as follows:

1. Press 

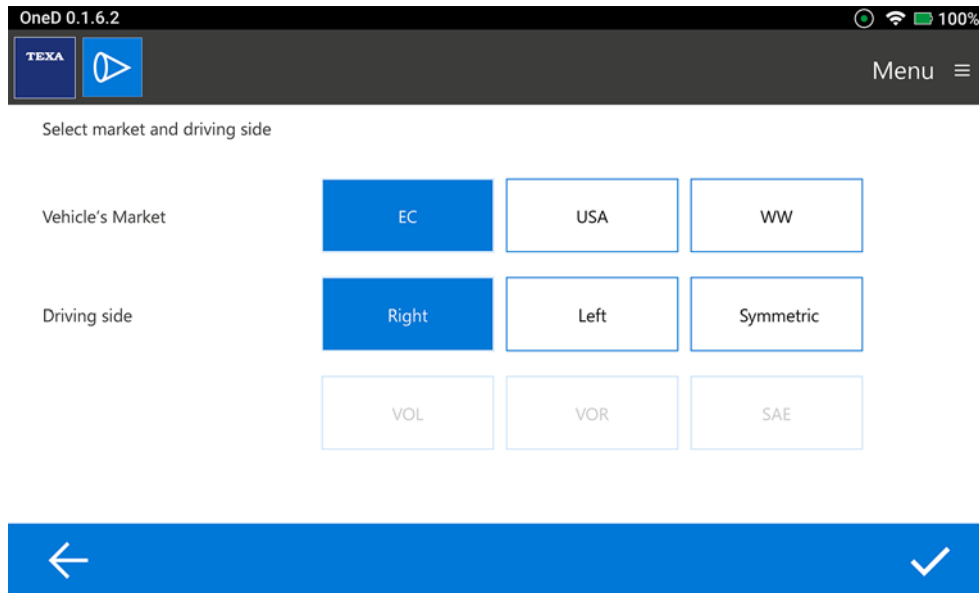
The **Light Geometry** screen is displayed.



Icon	Name	Description
	Back	Allows you to return to the previous screen.
	Confirm	It allows you to confirm the selections made.

2. Set the **Vehicle's Market and Driving Side**:

Vehicle's Market	Driving Side					
	Right	Left	Symmetric	VOL	VOR	SAE
EC : Europe	X	X	X			
USA : United States			X	X	X	X
WW : Worldwide	X	X	X	X	X	X

For further information see the **Photometry Overview** chapter.

4. Press 

LANGUAGE



This menu allows you to change the language in which the software is displayed.

Proceed as follows:

1. Press 

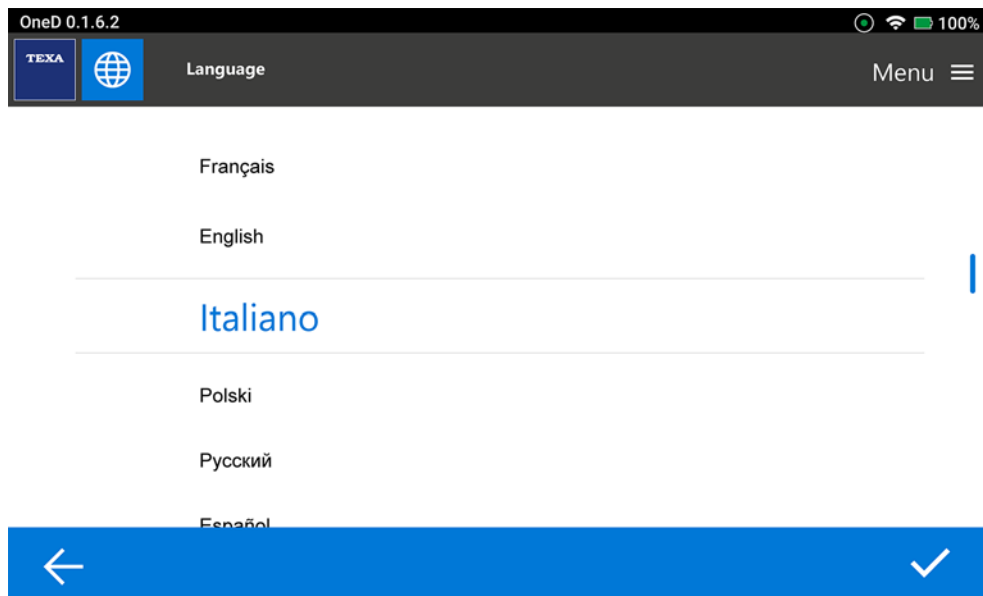
The **Language selection** screen is displayed.



Icon	Name	Description
	Back	Allows you to return to the previous screen.
	Confirm	It allows you to confirm the selections made.

TIME ZONE



It allows you to set the date and time for the country or zone where the tool is used.

Proceed as follows:

1. Press 

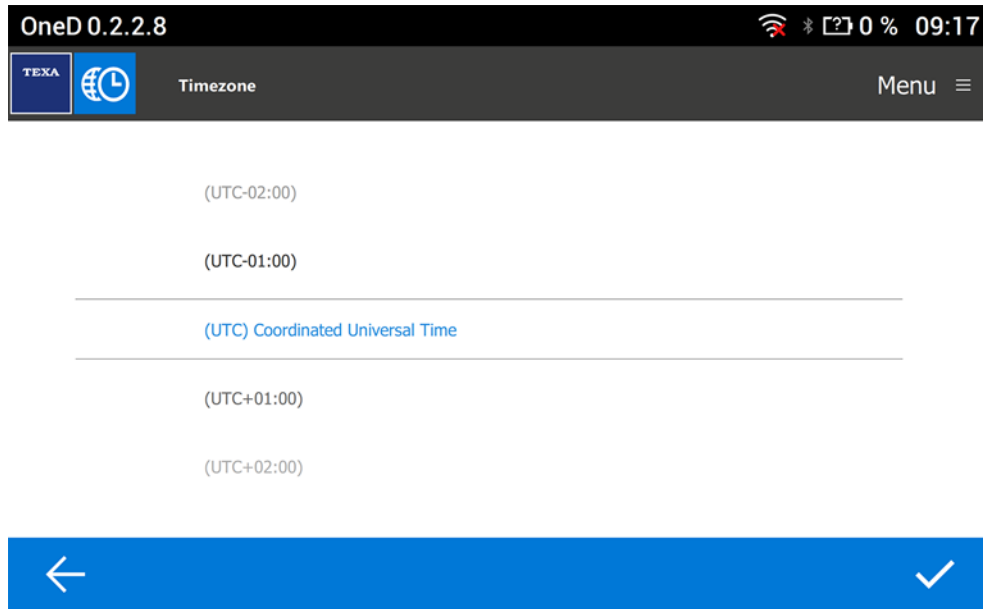
The **Time Zone** screen is displayed.



Icon	Name	Description
	Back	Allows you to return to the previous screen.
	Confirm	It allows you to confirm the selections made.

Wi-Fi

This menu allows you to configure the connection between the tool and the display unit. The tool is compatible with the smartphone Tethering / Hotspot Wi-Fi networks.



For more information see the smartphone user manual.

Proceed as follows:

1. Press 

The **Wi-Fi** screen is displayed.

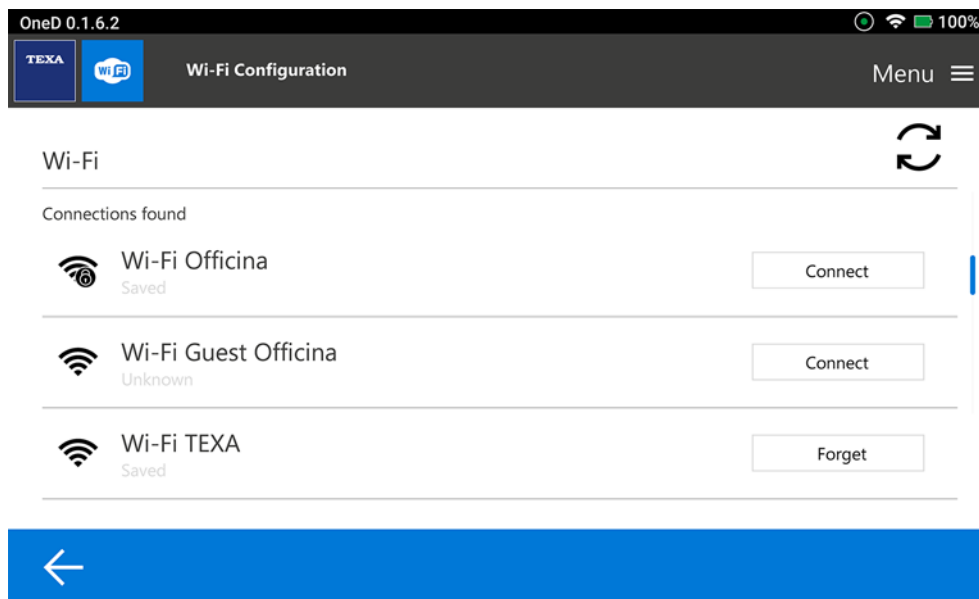

2. Select the correct Wi-Fi network by pressing **Connect**.

3. Enter the password if the network is encrypted.

4. Press **Connect**.

5. If necessary, restart the Wi-Fi network scan by pressing 

INFORMATION

The tool will not be connected if the Wi-Fi data was not entered correctly.

UPDATES

This menu allows you to check for updates and download them.
It also checks if updates are available in the connected HASP key.

INFORMATION

You must have an active Internet connection.

The complete download of these updates may take several minutes.
Proceed as follows:

1. Press 

The **Updates** screen is displayed.

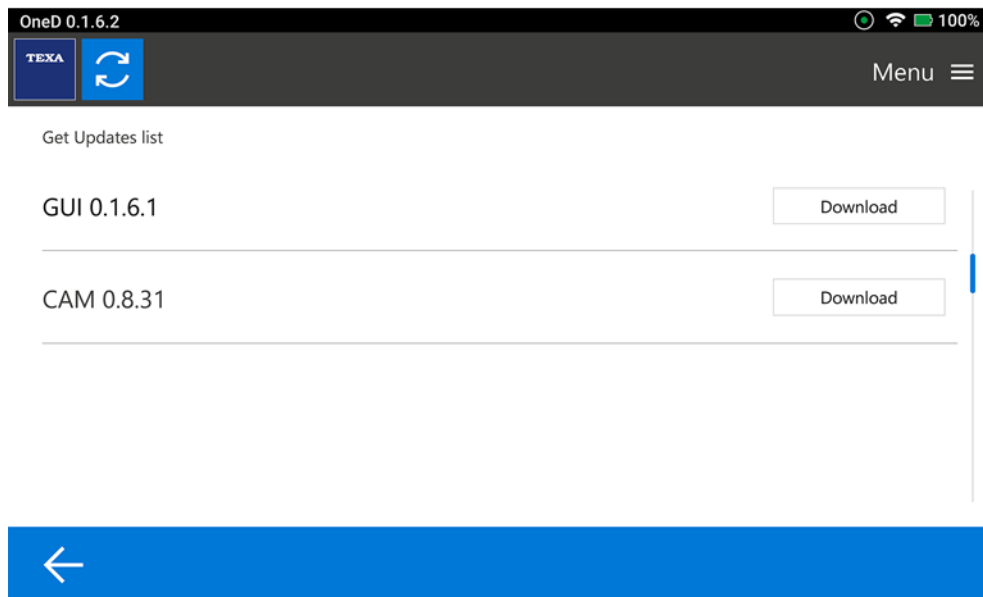

2. Select the desired update.

3. Press **Download**.

Wait for the update to complete.

VCI CONFIGURATION

This menu allows you to configure the diagnostic devices required to use the **DIAG TEST** software.

Proceed as follows:

1. Press 

The **VCI configuration** screen is displayed.

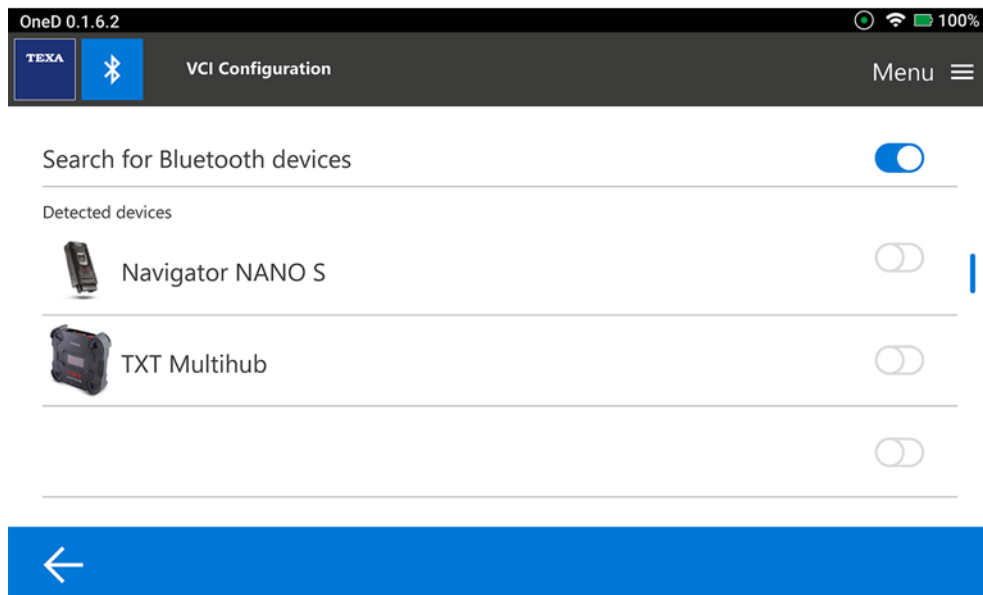

2. Select and enable the diagnostic tool that must be configured.

3. Follow the instructions that appear on screen.

Wait for the configuration to complete.

WORKSHOP PROFILE



This menu allows you to set the information regarding the workshop that must be printed on the reports of the tests carried out.

Proceed as follows:

1. Press 

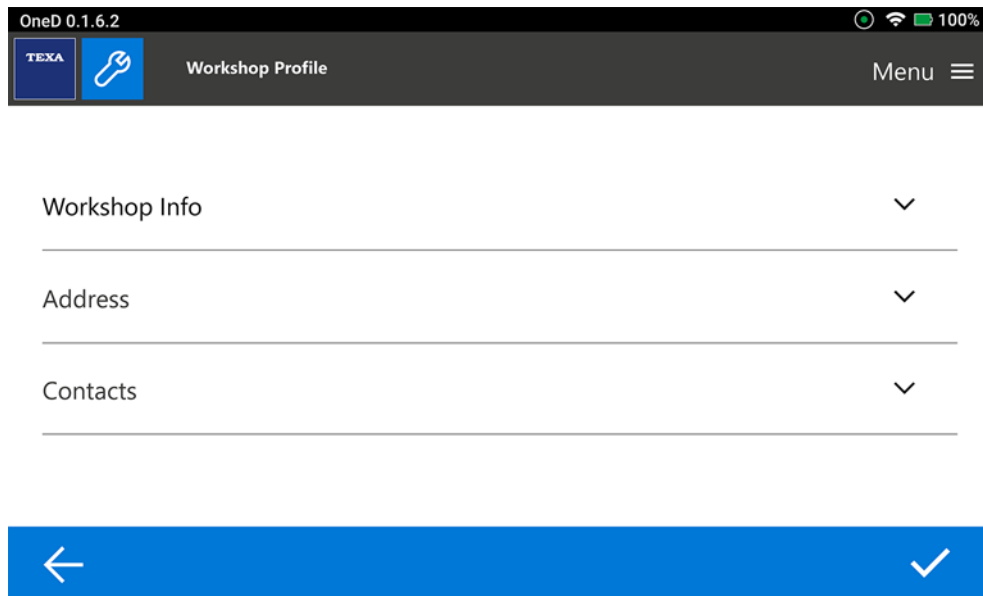
The **Workshop Profile** screen is displayed.



Icon	Name	Description
	Back	Allows you to return to the previous screen.
	Confirm	It allows you to confirm the selections made.

Proceed as follows to insert the data relating to:

- *Workshop Info*;
- *Address*;
- *Contacts*.

1. Press 

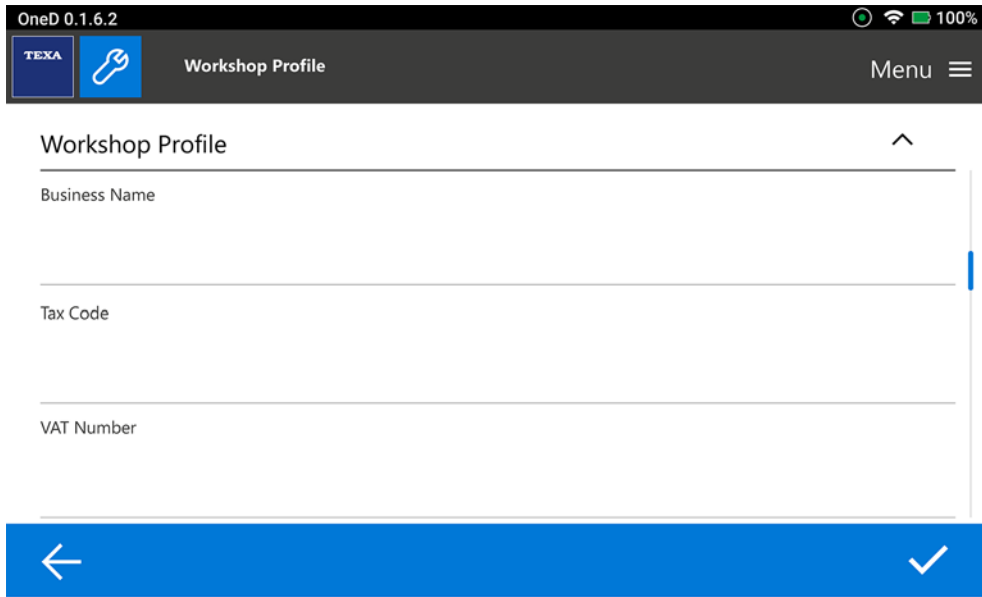

OneD 0.1.6.2 100%

Workshop Profile Menu

Workshop Profile ^

Business Name

Tax Code

VAT Number

← ✓

Enter the required information in the specific fields.

2. Press 

VERSION INFO

This menu provides information on the software version.

Proceed as follows:

1. Press 

The **Version Info** screen is displayed.



Serial Number: TESTS000001

LightTest: v 0.2.2.6

DiagTest: v 1.0.0

HASP ID: 1234567890

Copyright



Icon	Name	Description
	Back	Allows you to return to the previous screen.

SOFTWARE ACTIVATION

This menu allows you to activate the software.

INFORMATION

In order for the software to start properly, it must be purchased and then activated using the specific code.

The activation through the code is carried out automatically the first time the software is started, if the tool is connected to an active Wi-Fi network.

Proceed with the activation only if it has NOT been already carried out during the first installation.

For further information, contact your retailer.

Proceed as follows:

1. Press 

The **Software Activation** screen is displayed.

Example of LIGHT TEST Software Activation:

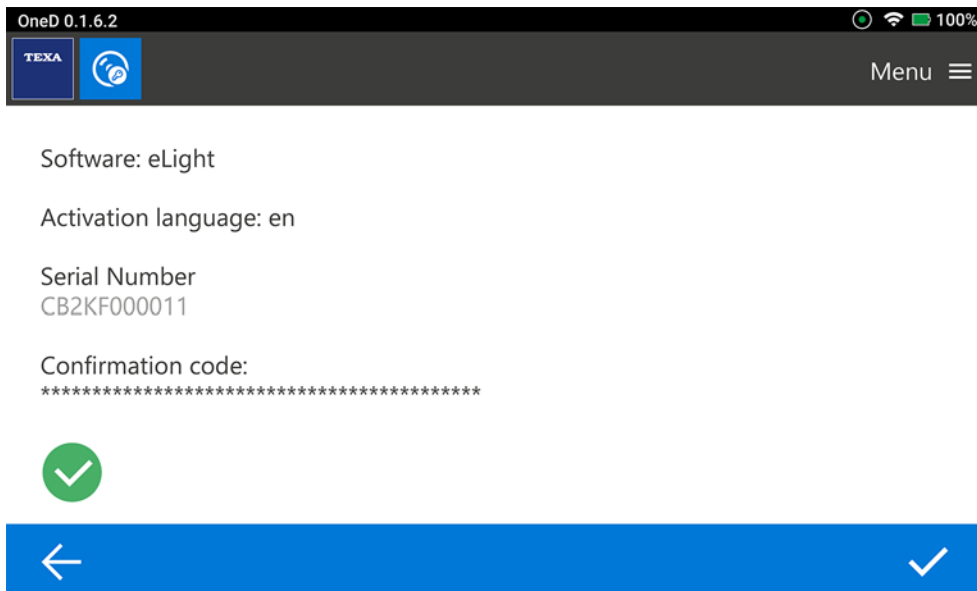

2. Enter the Confirmation code if the tool is not connected to an active Wi-Fi network.

INFORMATION

For further information, contact your retailer.

SERVICE

This menu allows you to access the customer service functions.

NOTICE



These functions must be used only if indicated to do so by the Technical Assistance.

Proceed as follows:

1. Press 

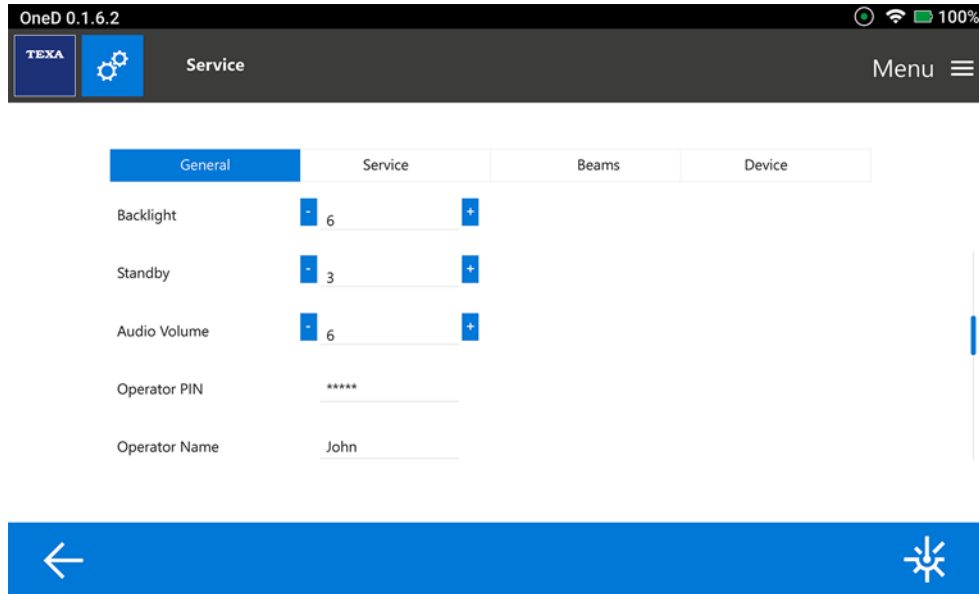
The **Service** screen is displayed.



Icon	Name	Description
	Back	Allows you to return to the previous screen.
	Laser	It allows you to check the activation and operation of the lasers positioned under and on the side of the optical box.

Follow the indications and/or requests of the Technical Assistance.

62.10.2 Updates

This menu allows you to check for updates and download them. It also checks if updates are available in the connected HASP key.

INFORMATION

You must have an active Internet connection.

The complete download of these updates may take several minutes. Proceed as follows:

1. Press 

The **Updates** screen is displayed.

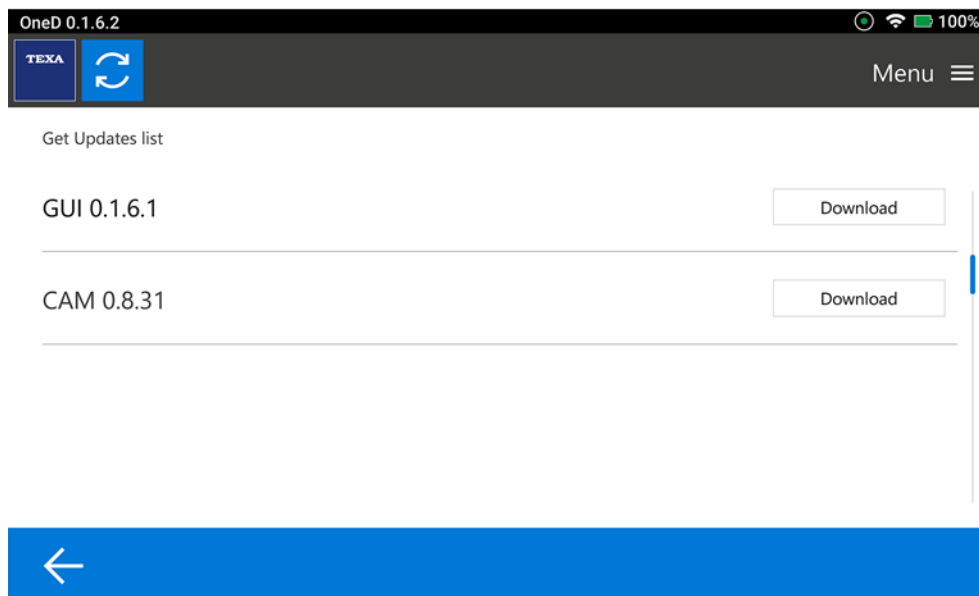

Icon	Name	Description
	Back	Allows you to return to the previous screen.

2. Select the desired update.

3. Press **Download**.

Wait for the update to complete.



63 UTILITIES SECTIONS

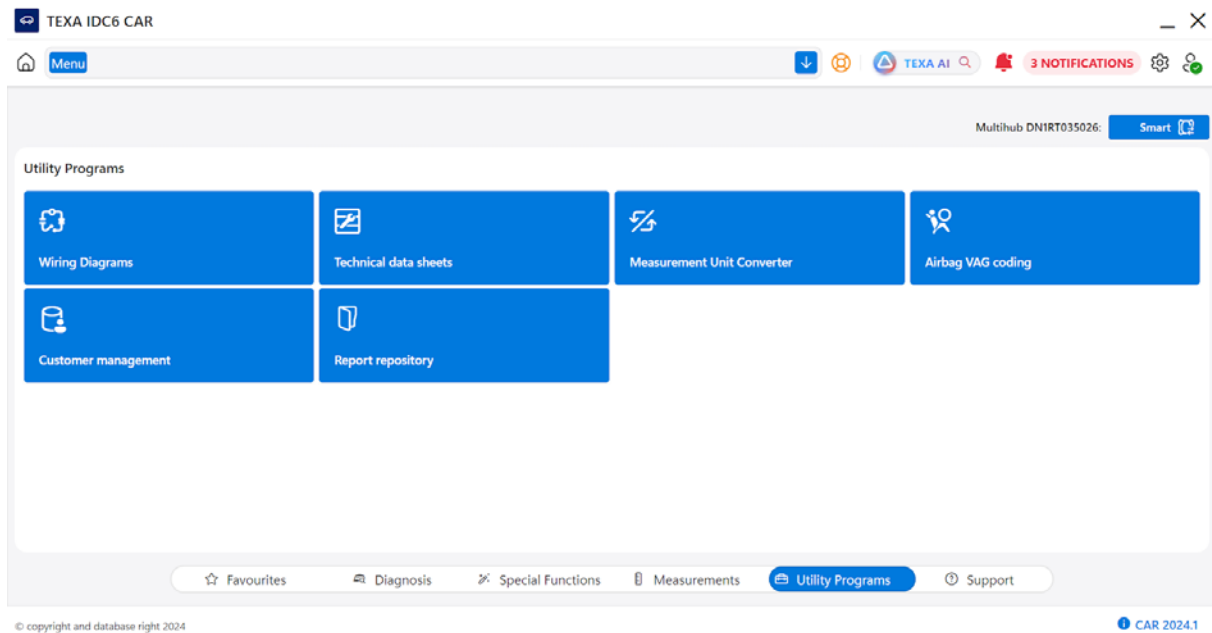

This section gathers the utility accessory functions.



Icon	Name	Description
	Wiring diagrams	It allows displaying the wiring diagrams related to the selection made.
	Technical data sheets	It allows accessing the support information in specific pages that appear when selecting the vehicle.
	Measurement unit converter	It allows converting a value input into different units of measurement. The conversions are divided by subject (for ex.: acceleration, fuel consumptions, frequency, etc.).
	Customer management	It allows managing the workshop's customer archive.
	Report repository	It allows accessing the folder in which the files in XML and PDF format are archived and exported from the Self-diagnosis and TGS3s functions.
	Airbag VAG coding	It allows calculating the codes needed to code a new airbag control unit of the VAG Group.
	Exchange manager	It allows managing the control unit firmware.
	BIKE CABLES	It allows accessing the database of the specific cables for the BIKE environment.
	MARINE CABLES	It allows accessing the database of the specific cables for the MARINE environment.

	TRUCK CABLES	It allows accessing the database of the specific cables for the TRUCK environment.
	OHW CABLES	It allows accessing the database of the specific cables for the OHW environment.

INFORMATION

Some functions may not be available for all the environments or on all the platforms.

64 WIRING DIAGRAMS



This function allows you to view the wiring diagrams relative to the selection made.

The wiring diagrams provided comply with proprietary standards and refer to specific electronic systems installed in the vehicle.

The components of an electronic system are indicated using standard symbols.

By moving the cursor on top of one of the symbols in the wiring diagram, a description that identifies the corresponding component and indicates its position will appear.

By pressing on the symbol of a component, a menu with the available functions is displayed.

Proceed as follows:

1. Press: 

2. Carry out a complete vehicle selection.

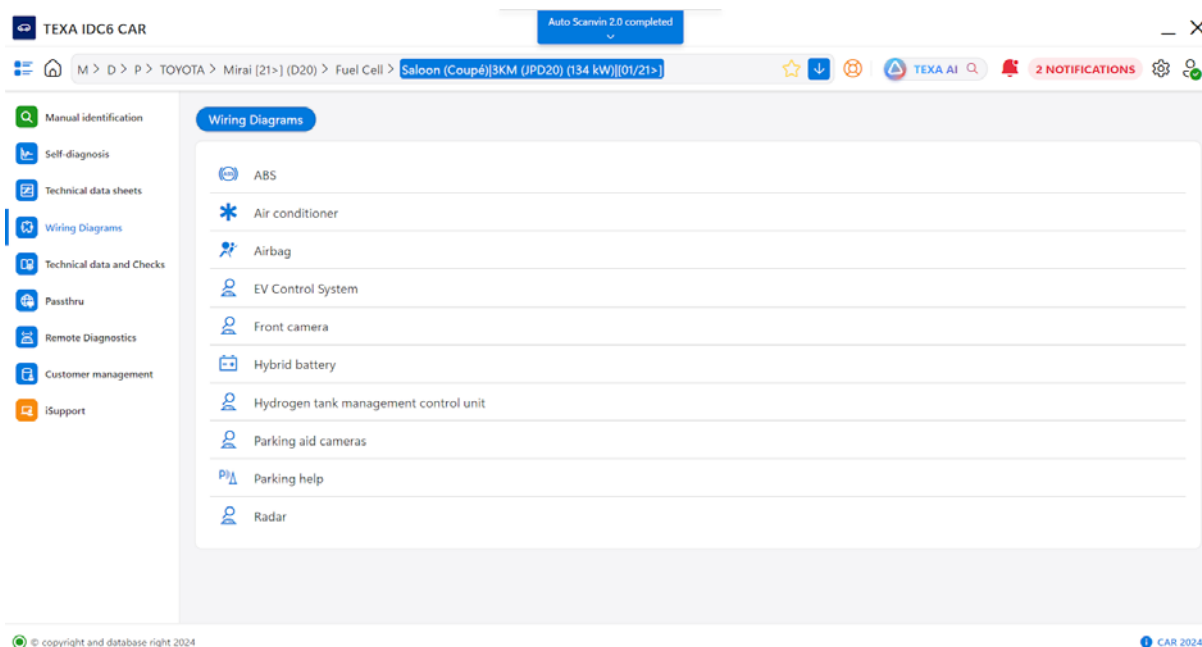

The screenshot shows the TEWA IDC6 CAR software interface. The top navigation bar includes the text 'TOYOTA > Mirai [21>] (D20) > Fuel Cell > Saloon (Coupé)[3KM (JPD20) (134 kW)][01/21>]'. A sidebar on the left contains a list of menu items: Manual identification, Self-diagnosis, Technical data sheets, Wiring Diagrams (highlighted), Technical data and Checks, Passthru, Remote Diagnostics, Customer management, and iSupport. The main content area is titled 'Wiring Diagrams' and displays a list of vehicle components with their respective icons:

- ABS
- Air conditioner
- Airbag
- EV Control System
- Front camera
- Hybrid battery
- Hydrogen tank management control unit
- Parking aid cameras
- Parking help
- Radar

At the bottom left, there is a copyright notice: '© copyright and database right 2024'. At the bottom right, there is a version identifier: 'CAR 2024.1'.

3. Select the desired system.

The screenshot displays the TEXA IDC6 CAR software interface. At the top, a blue notification bar reads "Auto Scanwin 2.0 completed". The breadcrumb navigation path is: M > D > P > TOYOTA > Mirai [21>] (D20) > Fuel Cell > Saloon (Coupé)[3KM (JPD20) (134 kW)][01/21>]. The left sidebar contains a menu with the following items: Manual identification, Self-diagnosis, Technical data sheets, Wiring Diagrams (highlighted), Technical data and Checks, Passthru, Remote Diagnostics, Customer management, and iSupport. The main content area is titled "Wiring Diagrams" and lists the following systems: ABS (with sub-item ABS/EPB > [>12/23]), Air conditioner, Airbag, EV Control System, Front camera, Hybrid battery, Hydrogen tank management control unit, Parking aid cameras, Parking help, and Radar. At the bottom left, there is a copyright notice: "© copyright and database right 2024". At the bottom right, there is a version indicator: "CAR 2024.1".

4. Select the desired variant.



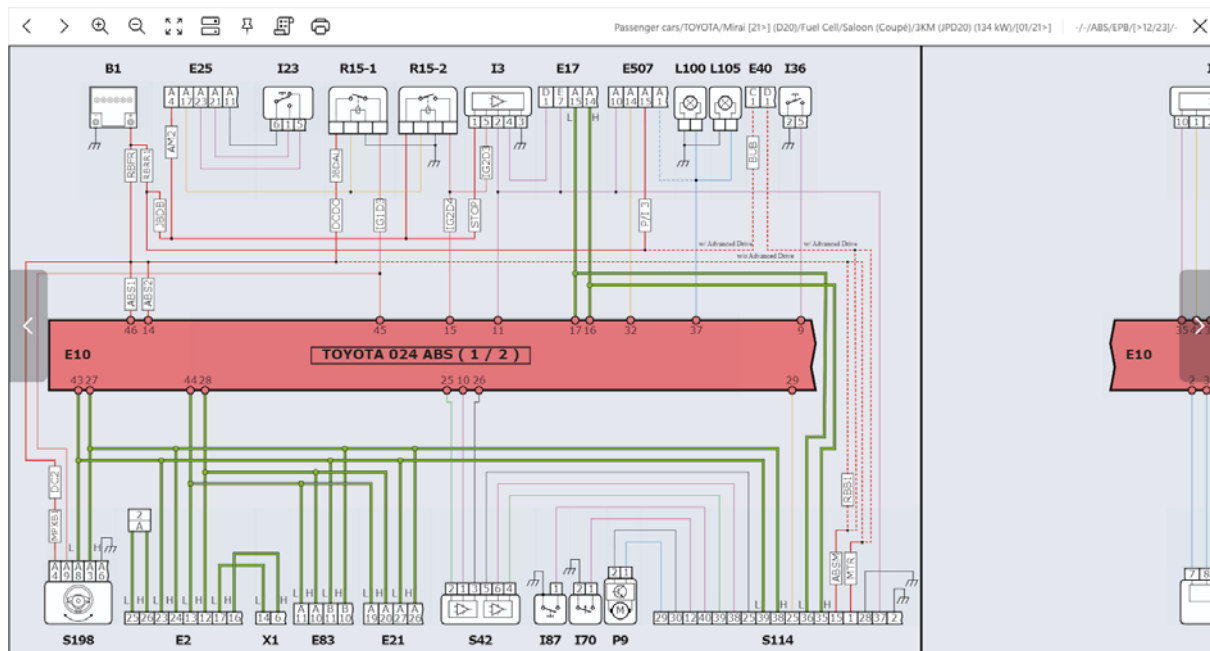

The selected wiring diagram is displayed.

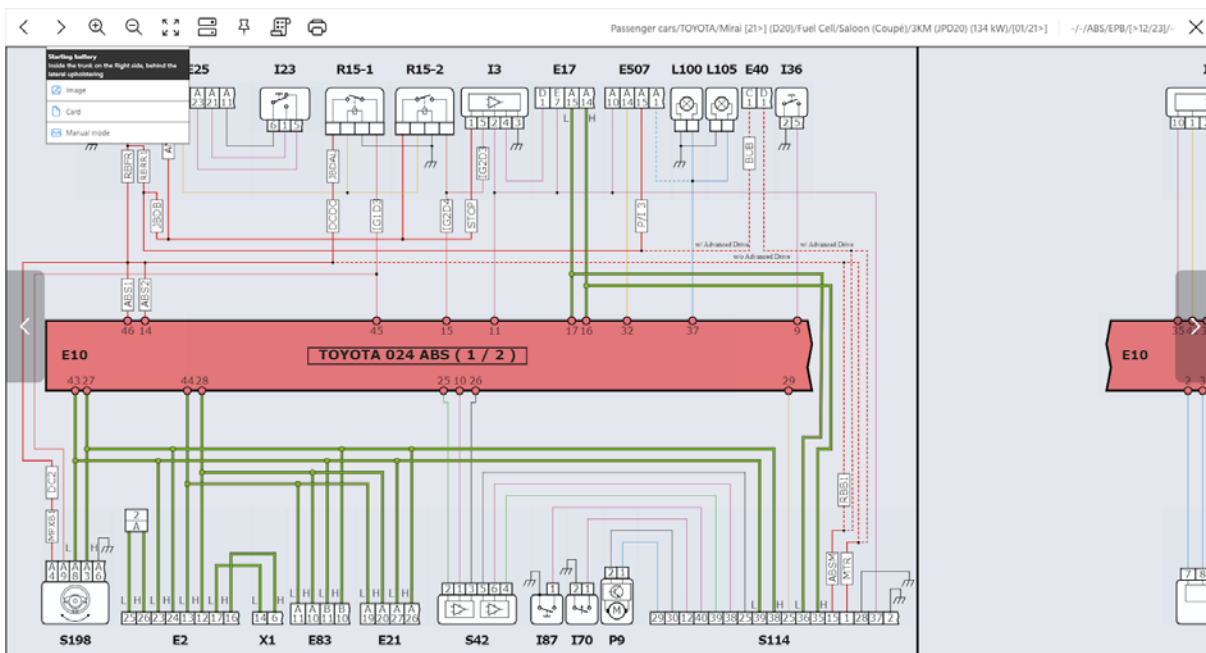

Icon	Name	Description
< / >	Previous / Next Page	Allows you to move from one page of a wiring diagram to another.
⊕ / ⊖	Zoom In / Out	It allows you to zoom in / out on a part of the diagram. Once they have been enlarged, you can navigate through the wiring diagrams by dragging the cursor towards the desired area.
↶ ↷	Full screen	Allows you to have a full-screen view of the wiring diagram.
☰	Component list	It allows you to view the list of components contained in the wiring diagram. By selecting a line in the legend, the corresponding component is highlighted in the wiring diagram.
📌	Device Location	It allows you to view the position of the selected component in the example vehicle's outline. The position of the spot changes as you move the cursor over another component.
📖	Wiring Diagram Key	Allows you to view the colour codes used within the diagram to explain the various types of connections. The colour code within the key is used to indicate the type of signal or the power supply within a specific connection.
🖨️	Print	Allows you to print the wiring diagram or the legends/keys.



Below there is an example of the functions and information available for the selected component.

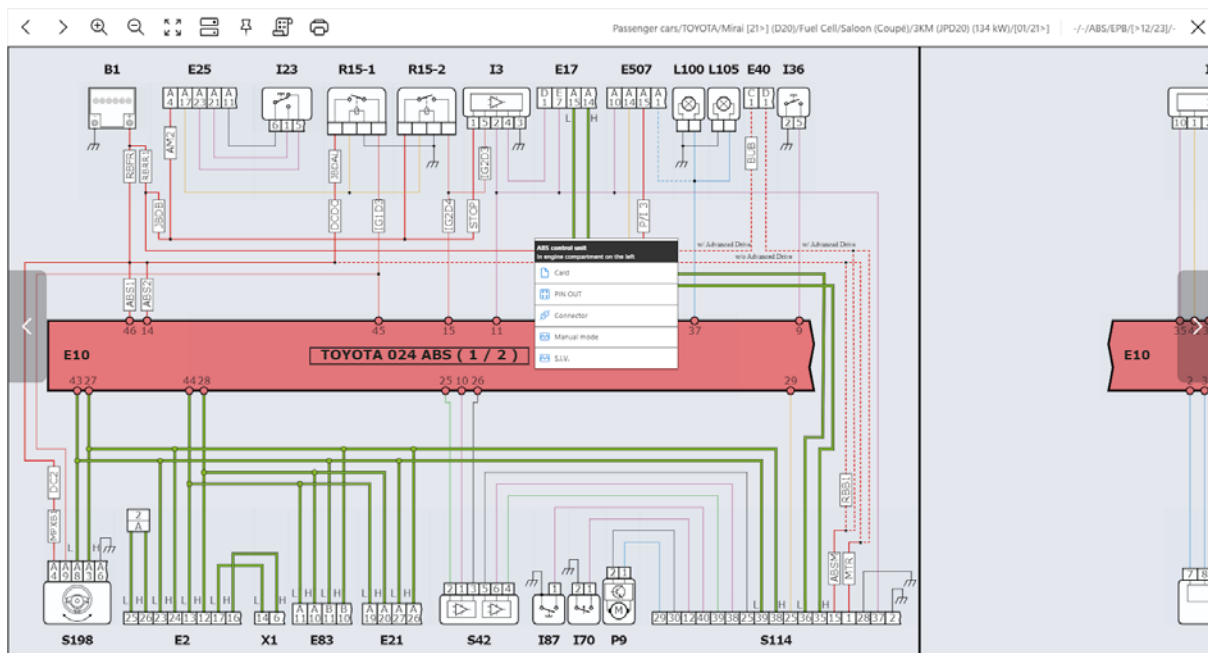

Icon	Name	Description
	Image	It allows you to view a photo or a drawing of the selected component. The image changes as you move the cursor over another component.
	Technical data sheet	It allows you to access one or more documents related to the selected component.
	Manual	It allows launching the Oscilloscope function in manual mode.
	S.I.V.	It allows launching the Oscilloscope function in S.I.V. (Signal Information Viewing) mode. In this mode the oscilloscope allows checking the quality of the signal present on the selected component.

In particular, some extra information is provided by pressing on the control unit.



Icon	Name	Description
	Pinout	It allows you to view a list indicating the control unit's pinout.
	Connector	It allows you to view an image of the control unit's diagnostic connector. Before being able to view the connector, you must accept a specific disclaimer.

65 TECHNICAL DATA SHEETS



This function allows accessing the support information provided by the software.

Proceed as follows:

1. Press: 

2. Carry out a complete vehicle selection.

TEXA IDC6 CAR



M > D > P > TOYOTA > Mirai [21>] (D20) > Fuel Cell > Saloon (C



Manual identification



Self-diagnosis



Technical data sheets



Wiring Diagrams



Technical data and Checks



Passthru



Remote Diagnostics



Customer management



iSupport

System sheets

Vehicle sheets



Air conditioner



Airbag

The screen is divided into the following pages:

Name	Description
System Sheets	It allows viewing all the Bulletins and Technical data sheets available for the selection made, divided by system and variant.
Vehicle Sheets	It allows viewing all the Bulletins and Technical data sheets that are available during the vehicle selection phases.

Below the differences between **Bulletins** and **Technical data sheets** are explained:

Name	Description
Bulletins	Generally the Bulletins are documents that refer to a specific fault. The bulletin provides straightforward information on the probable cause of the problem and the correct procedure in order to solve and eliminate the problem.
Technical data sheets	The Technical data sheets describe the characteristics and operating strategies of the different systems installed in the vehicle. The contents of the sheets are generally organised in the same way and include: <ul style="list-style-type: none">• <i>general description of the system;</i>• <i>operating strategies and particular features;</i>• <i>position and images of the components.</i>

65.1 System Sheets

In this page you can view all the **Bulletins** and **Technical data sheets** available for the selection made, divided by system and variant.

Proceed as follows:

1. Press: **System Sheets**
2. Select the desired system.

The screenshot shows the TEVA IDC6 CAR interface. The breadcrumb trail indicates the path: M > D > P > TOYOTA > Mirai [21>] (D20) > Fuel Cell > Saloon (Coupé) [3KM (JPD20) (134 kW)] [01/21>]. The 'System sheets' tab is active, displaying a list of systems: Air conditioner and Airbag. Below this, a table lists system sheets:

Type	Date	Title
BLT	09/25/2006	Correct system selection - Abbreviation list
FNZ	06/30/2005	Airbag systems

3. Select the variant.
4. Select the bulletin or the technical data sheet.

The selected bulletin or technical data sheet is displayed.

The screenshot shows a 'Technical info sheet' for the bulletin '25/09/2006 Correct system selection - Abbreviation list'. The text explains that in order to select correctly the diagnosis and / or the wiring diagram of the Airbag system, the following tables show the relevant acronyms related to various types of systems which can be selected from the instrument menu. It notes that as a matter of fact, it is possible to find abbreviations such as "...2F-2P-2L-2T" can be found. They identify the vehicle airbag system components. A yellow highlight states: "As far as the auto diagnosis is concerned, the inappropriate selection can lead to incorrect readings or absence of status and / or parameters."

- **1F** only one driver side front explosive charge
- **2F** two front charges, driver and the passenger side
- **2P** two belts' charges, one on the driver's side and one on the passenger's side
- **4P** as 2P with the addition of two more pretensioners in the rear belts
- **PG** Driver side pretensioner charge
- **PP** Passenger side pretensioner charge
- **2L** two lateral charges, driver and passenger (usually placed in the front seats)
- **4L** as 2L with addition of two more Lateral charges in the rear seat
- **2T** two charges for curtain airbag to protect the hood during lateral crash, one on the driver's side and one on the passenger's side
- **G** airbag charge for Knee protection
- Charge exclusion switch on the passenger's side (normally key on the passenger's side)
- **ZI** like I with the addition of a switch (normally in the boot) for rear seat charge exclusion with arrangement for baby's seat clasp
- **S** Passenger occupancy sensor, on the passenger side seat
- **SB** clasp/sensor for Baby's seat
- **C** belt clasp switches

Example

'2F-4P-4L-2T-2I-S' shows a protection system with: a Front charge on the driver's side, a Front charge on the passenger's side, two front and two rear pretensioner charges, two Lateral charges integrated to the front seats and two to the rears, two charges for curtain airbags, two airbag charge exclusion switches.

65.2 Vehicle Sheets

In this page you can view all the **Bulletins** and **Technical data sheets** that are available during the vehicle selection phases.

INFORMATION

This information is specific for the selection level.

There are specific bulletins and technical data sheets based on the make, model, engine type, etc.

If the icon disappears when switching to the following selection level, this means that there are no technical data sheets available for the selected level.

1. Press: **Vehicle Sheets**
2. Select the System.

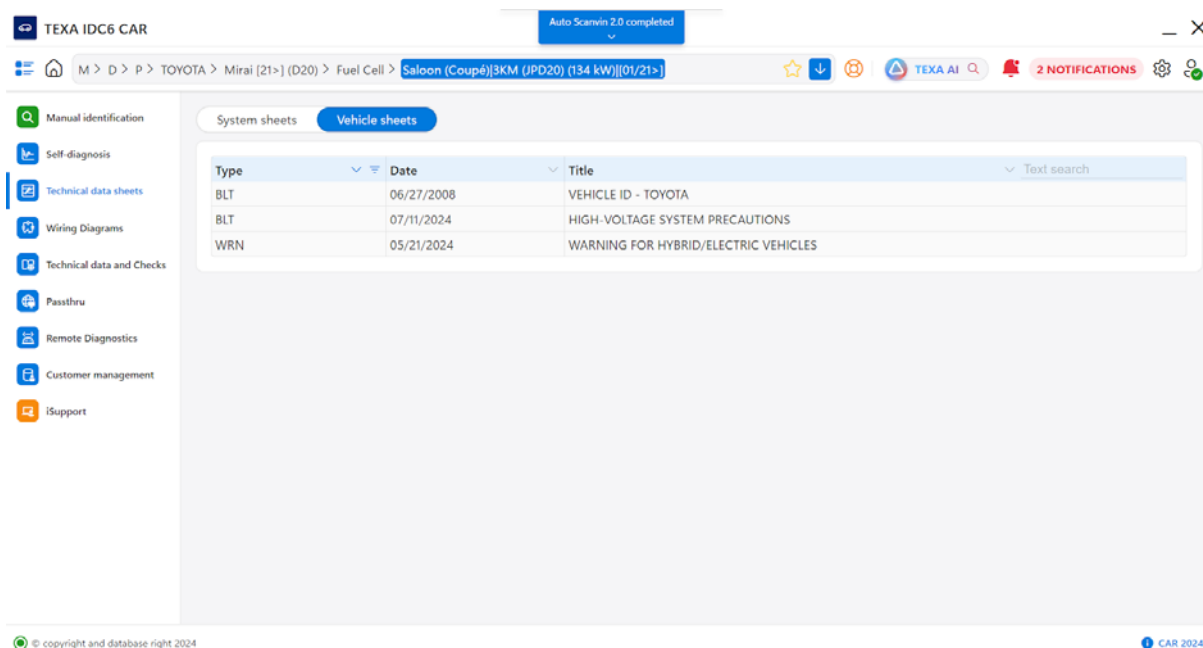

Type	Date	Title
BLT	06/27/2008	VEHICLE ID - TOYOTA
BLT	07/11/2024	HIGH-VOLTAGE SYSTEM PRECAUTIONS
WRN	05/21/2024	WARNING FOR HYBRID/ELECTRIC VEHICLES

3. Select the bulletin or the technical data sheet.
- The selected bulletin or technical data sheet is displayed.

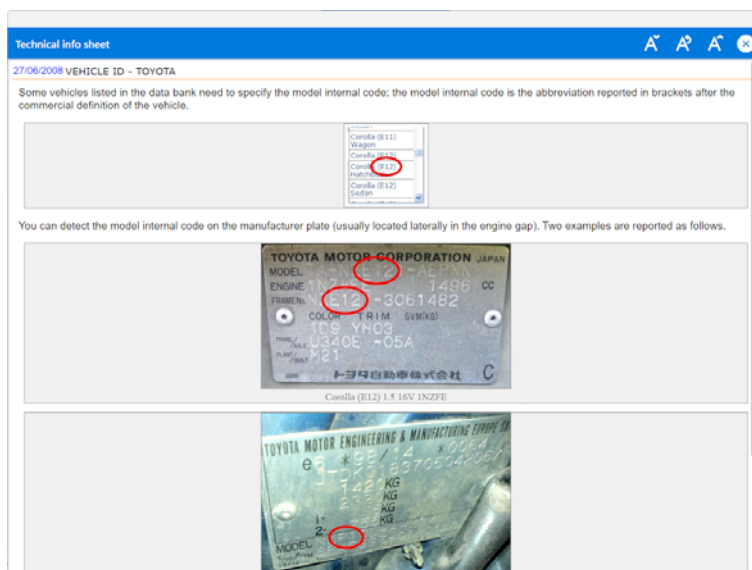

Technical info sheet

27/06/2008 VEHICLE ID - TOYOTA

Some vehicles listed in the data bank need to specify the model internal code; the model internal code is the abbreviation reported in brackets after the commercial definition of the vehicle.

You can detect the model internal code on the manufacturer plate (usually located laterally in the engine gap). Two examples are reported as follows.

Corolla (E112) 1.5 16V 1NZFE

66 MEASUREMENT UNIT CONVERTER



This function allows displaying the conversion of a value entered in different units of measurement. Proceed as follows:

1. Press: 
2. Select the desired measure.

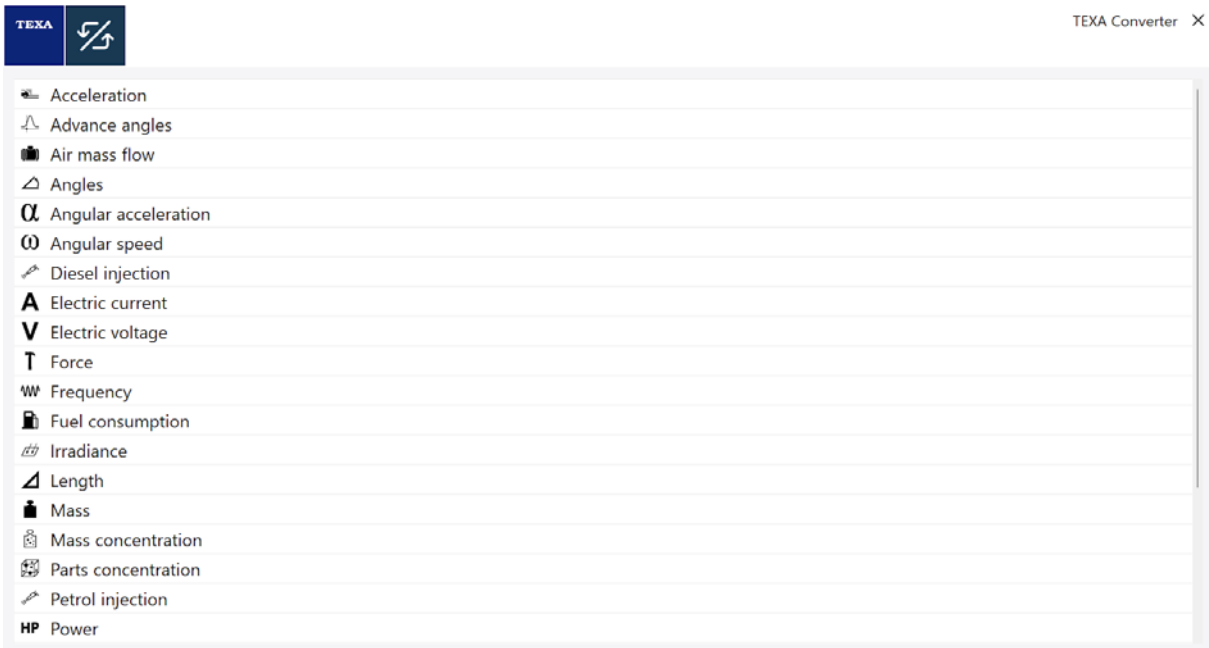

3. Press: 
4. Enter the value you wish to convert in the specific field.
5. Select the reference unit of measurement using the dropdown menu.

The software displays the conversion in all the available units of measurement.

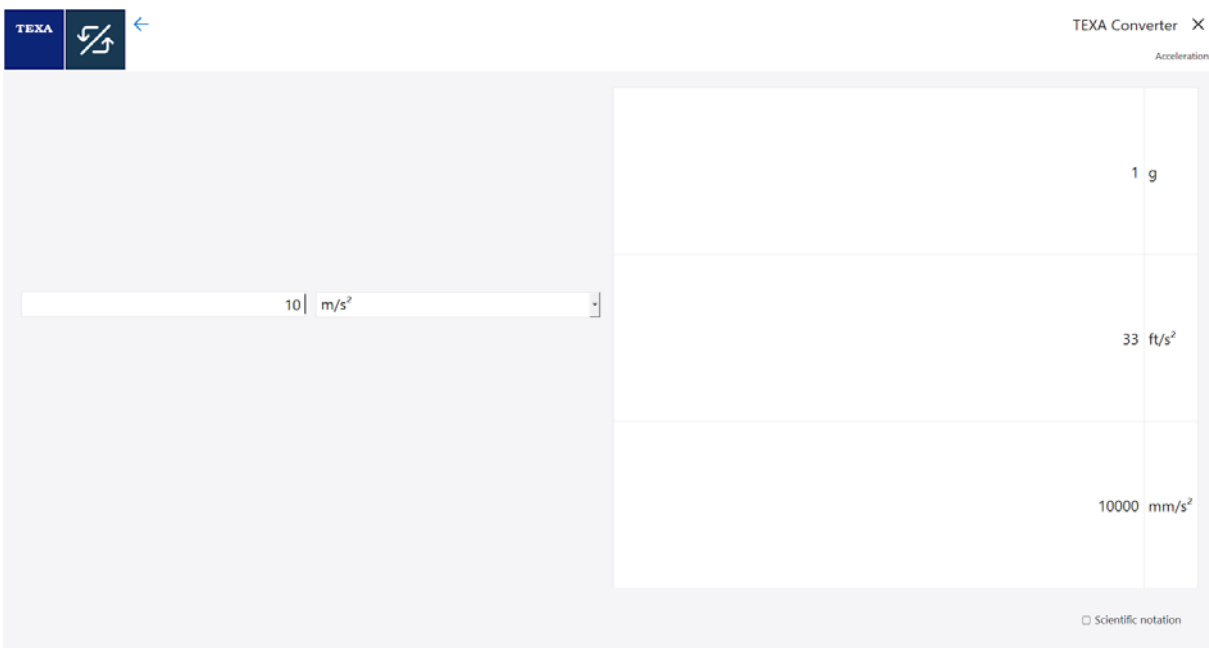

INFORMATION

By ticking the Scientific Notation box, you can display the results of the conversions through the scientific notation (times powers of ten).

67 AIRBAG VAG CODING



This function allows calculating the coding code of a new airbag control unit if it needs to be replaced.

If it is impossible to retrieve the coding code traditionally, you may calculate it using the identification code indicated on the new control unit's package.

The acquired coding code must be entered when requested by the diagnostic function **Control Unit Coding**.

Proceed as follows:



1. Press:

The screen for calculating the coding code is displayed.

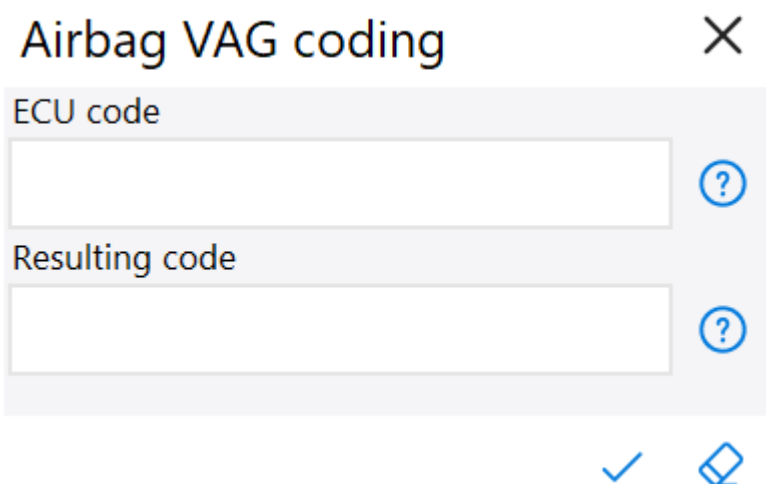

Icon	Name	Description
	Confirm	It allows you to calculate the new control unit's coding code.
	Delete	It allows you to delete the texts from all the text boxes.
	Information	It allows you to view help sheets related to the function and the replacement of the airbag control unit.

2. Enter the identification code of the control unit that must be replaced in the specific field.

Airbag VAG coding ✕

ECU code

 ?

Resulting code

 ?

✓ 📄

3. Press: ✓

The coding code is displayed.

Airbag VAG coding ✕

ECU code

 ?

Resulting code

 ?

✓ 📄

68 CUSTOMER DATA MANAGEMENT



This function allows you to manage the workshop's customer archive.

Once the function is launched, the customer search screen is displayed.

In the search field you may enter the following search keys:

- *the vehicle's license plate number or VIN;*
- *the customer's name or surname;*
- *information regarding the vehicle (make, model, engine type);*
- *date of the last action.*

By clicking on the line that corresponds to the desired customer, you reach a screen that is divided into three pages.





Name	Description
Repair	It allows you to enter or change the data related to the actions.
Vehicle Data	It allows you to change the data of the vehicle associated to the customer.
Client's Data	It allows you to modify the customer data.

From the main screen, you may also enter a new customer and set the model of the vehicle that will be used when carrying out operations.

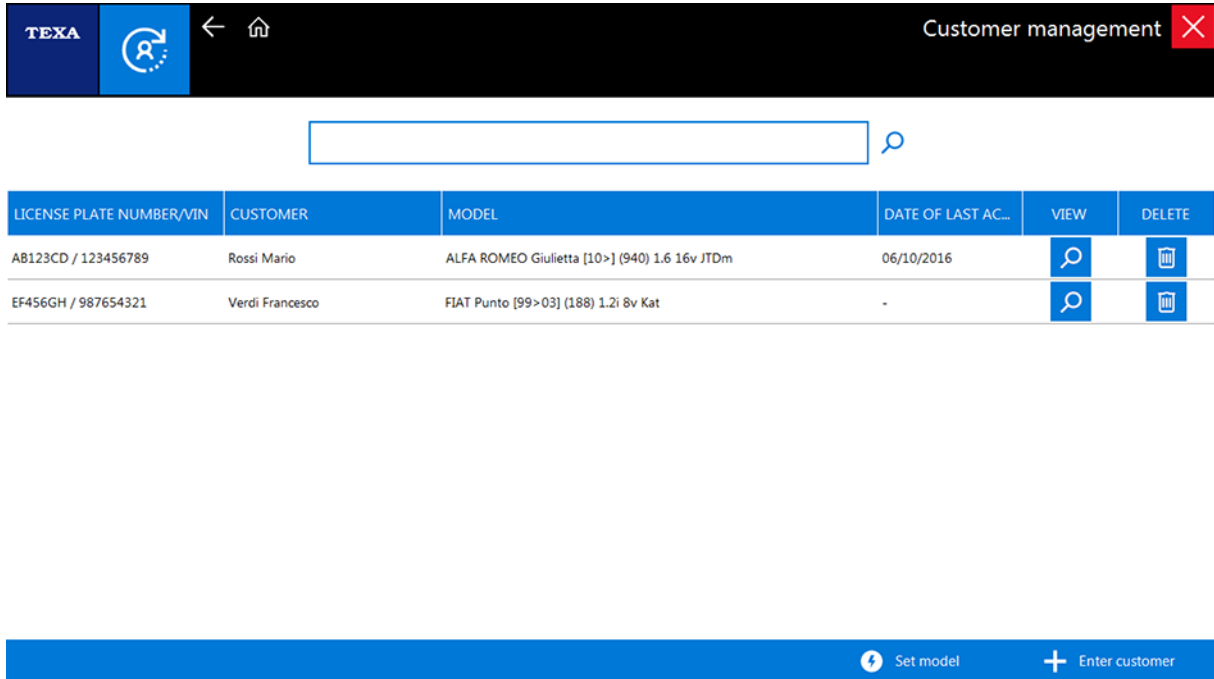
Proceed as follows:

1. Press: .
2. Enter the search key in the specific field.
3. Press on the row that corresponds to the desired customer or on one of the functions listed in the table below the screen.



Icon	Name	Description
	View	It allows you to view the screen for managing the actions, vehicle data and customer data.
	Delete	It allows you to delete the related customer.
	Set Model	It allows you to carry out a complete selection of the vehicle associated to the customer selected. This way you can use all the functions that save information in the Customer Management archive.
	Enter Customer	It allows you to enter the data related to a new customer into the archive.



68.1 Enter Customer

This function allows you to enter the data related to a new customer into the archive.

The software allows you to enter the data related to a vehicle temporarily, without having to associate a customer to it.

You cannot enter the data related to a customer without having entered the data of a vehicle first.

Proceed as follows:

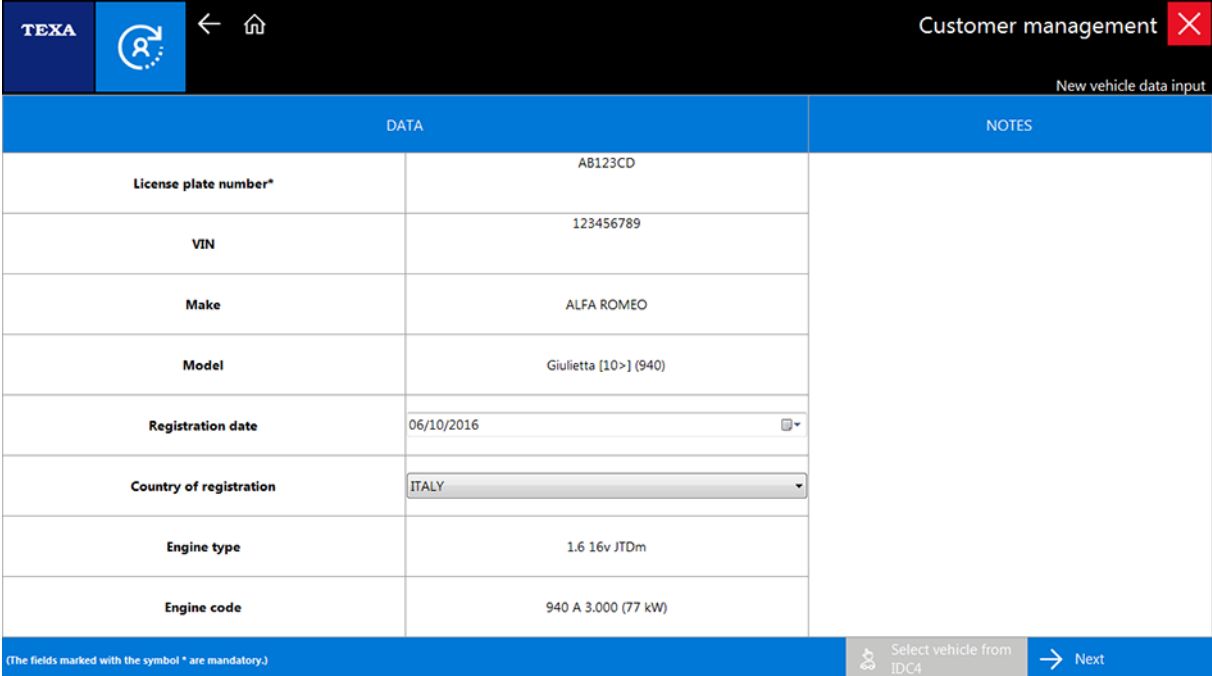

1. Press: .
- The **New Vehicle Data Input** screen is displayed.
2. Enter the required information in the specific fields.
3. Use the **Select Vehicle from IDC6** function to select the desired vehicle.
4. Press: .



DATA		NOTES
License plate number*	AB123CD	
VIN	123456789	
Make	ALFA ROMEO	
Model	Giulietta [10>] (940)	
Registration date	06/10/2016	
Country of registration	ITALY	
Engine type	1.6 16v JTDm	
Engine code	940 A 3.000 (77 kW)	



(The fields marked with the symbol * are mandatory.)

Select vehicle from IDC6 → Next

Icon	Name	Description
	Select Vehicle from IDC6	It allows you to select a vehicle through Vehicle Selection .
	Next	It allows you to switch to the screen for entering the customer's data.

The **Customer Data Input** screen is displayed.

5. Enter the required information in the specific fields.

Icon	Name	Description
	Reset	It allows you to delete all the fields.
	Search Customer	It allows you to select a customer among the ones already entered.
	Save	It allows you to save the customer - vehicle association.

6. Press: .

The customer's profile is entered and associated to a vehicle.

Once you have entered a customer, this latter will appear in the function's main screen.

68.2 Repair

In this page all the entered actions are displayed, divided into the operations required to complete them.

The operations available are:

- *self-diagnosis (error recording, parameter recording, screenshots, etc.);*
- *scheduled maintenance;*
- *oscilloscope (manual mode);*
- *free operation.*

Proceed as follows:



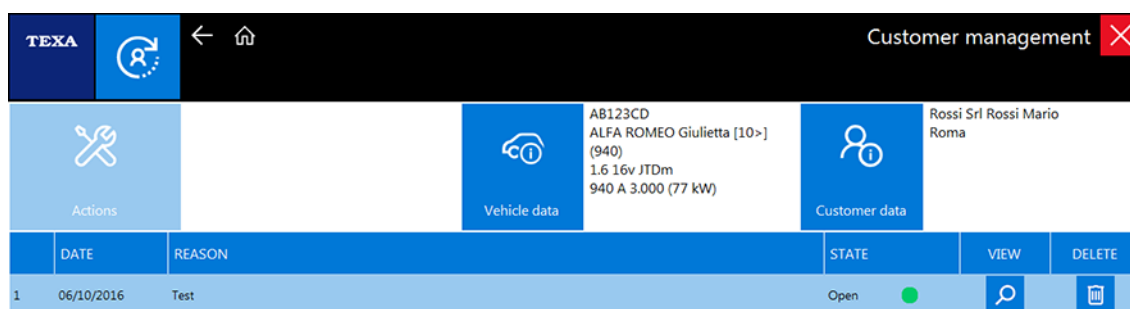

1. Press:**Actions**.
2. Press on the row that corresponds to the desired action or on one of the functions listed in the table below the screen.



Icon	Name	Description
	View	It allows you to view the screen for managing the operations.
	Delete	It allows you to delete the related action.
	Enter Action	It allows you to enter an action into the archive, with which different operations can be associated.

The operations associated to the selected action are displayed.

The screenshot shows the TEEXA Customer management interface. At the top, there is a navigation bar with the TEEXA logo, a home icon, and a 'Customer management' title with a close button. Below this, the 'ACTION DETAILS' section is divided into three panels: 'Actions' (with a wrench icon), 'Vehicle data' (showing AB123CD, ALFA ROMEO Giulietta [10>] (940), 1.6 16v JTDm, 940 A 3.000 (77 kW)), and 'Customer data' (showing Rossi Srl Rossi Mario, Roma). Below the panels is a table with columns: DATE, REASON FOR THE ACTION, MILEAGE (IN K...), STATE, and NOTES. The first row shows: 06/10/2016, Test, 20000, Open, and a green status indicator. At the bottom, there is a table with columns: DATE, TIME, OPERATION, VIEW, PRINT, and DELETE. The first row shows: 1, 06/10/2016, 15:01, Self-diagnosis (Diesel injection - EDC - 16 C 39), and icons for view, print, and delete. A blue bar at the bottom contains '+ Enter operation' and 'Save action'.

Icon	Name	Description
	View	It allows you to view the type of operations carried out.
	Print	It allows printing a report related to some particular tests.
	Delete	It allows you to delete the related action.
	Enter Operation	It allows inputting an operation into the archive manually.
	Save Action	It allows you to save the changes made.

From this screen you can edit the data related to the action (date, reason for the action, mileage, etc.).

Some operations are divided by type (for example: **Self-Diagnosis**).

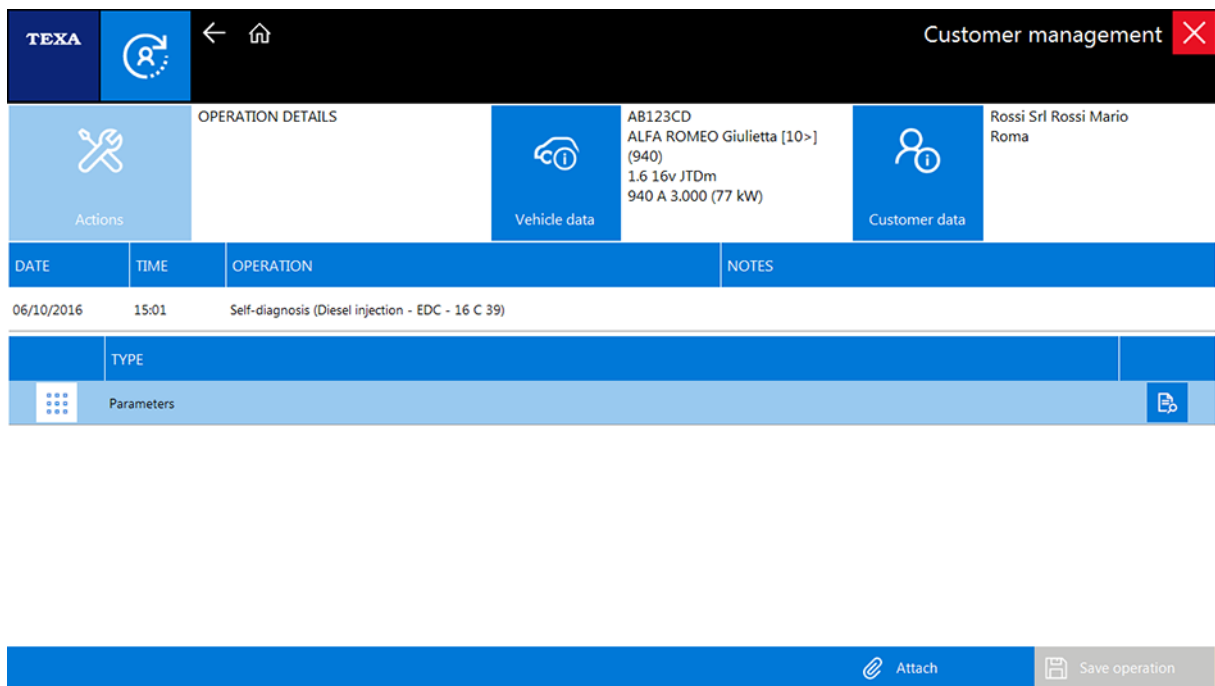

Icon	Name	Description
	View Data Operation	It allows you to view the information related to the selected operation.
	Send	It allows you to send to TEXA the support file created through the Fault Notification function. *
	Save Action	It allows you to save the changes made.

(*) For more information consult the Auto-diagnosis chapter.

From this screen you can edit the data related to the action (date, time, operation, etc.).

68.2.1 View Operation Data

This function allows you to view the information related to the selected operation.

Below there is an example of the display of diagrams obtained by registering the trend of some self-diagnostic parameters.

This screen allows:



- viewing all the information regarding the operation (workshop data, vehicle data, etc.);
- learning the exact value of a parameter in a specific moment simply by passing the cursor over the desired area;
- zooming in on a portion of the diagrams to have a more precise view of the trend of the values (making a selection on the desired portion of the diagram).

Proceed as follows:

1. Press: 

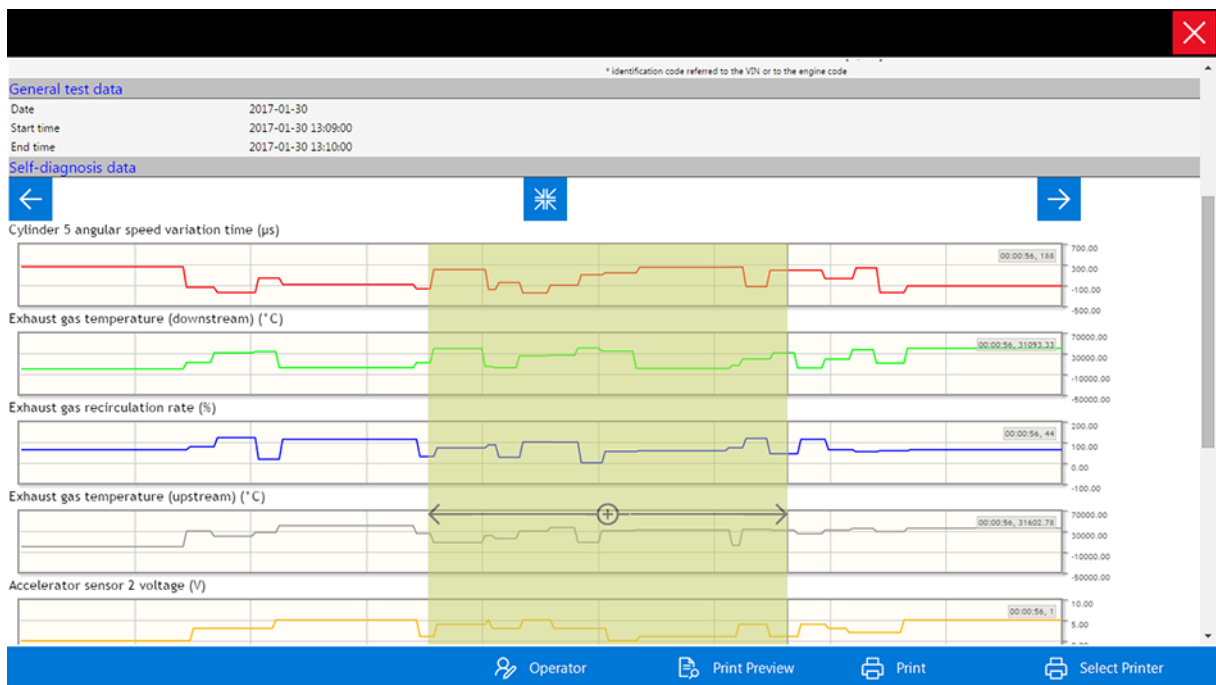
The diagrams of the registered parameters are displayed.





Icon	Name	Description
	Left Arrow	It allows moving towards the left part of the diagrams.
	Zoom Out	It allows returning to the full view of the diagrams.
	Right Arrow	It allows moving towards the right part of the diagrams.

68.2.2 Enter Action

This function allows you to enter an action into the archive, with which different operations can be associated.

Proceed as follows:

1. Press:  .
2. Enter the required information in the specific fields.
3. Press:  to save the action.
4. Press:  in the confirmation message.

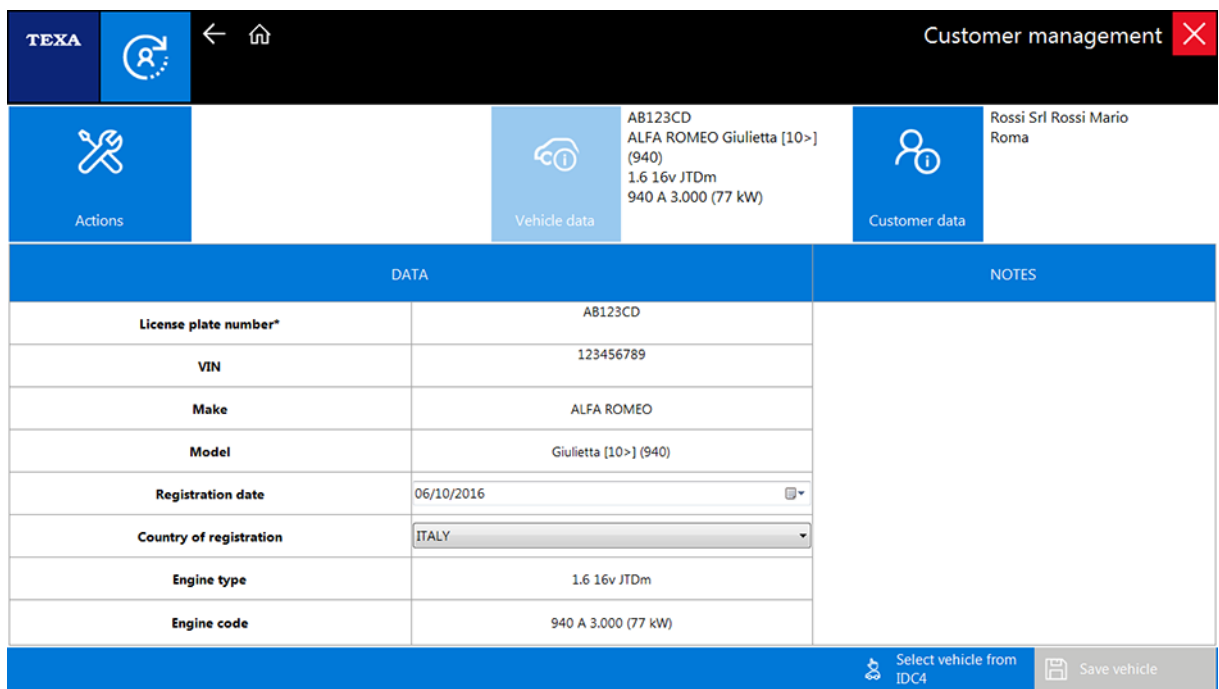



This screen is the same displayed if an action that is already entered is selected.

68.2.3 Enter Operation





This function allows inputting into the archive a free operation.

This type of operation is not associated to a test that was carried out, but it can be created manually by the user by entering the requested information and eventually an image.

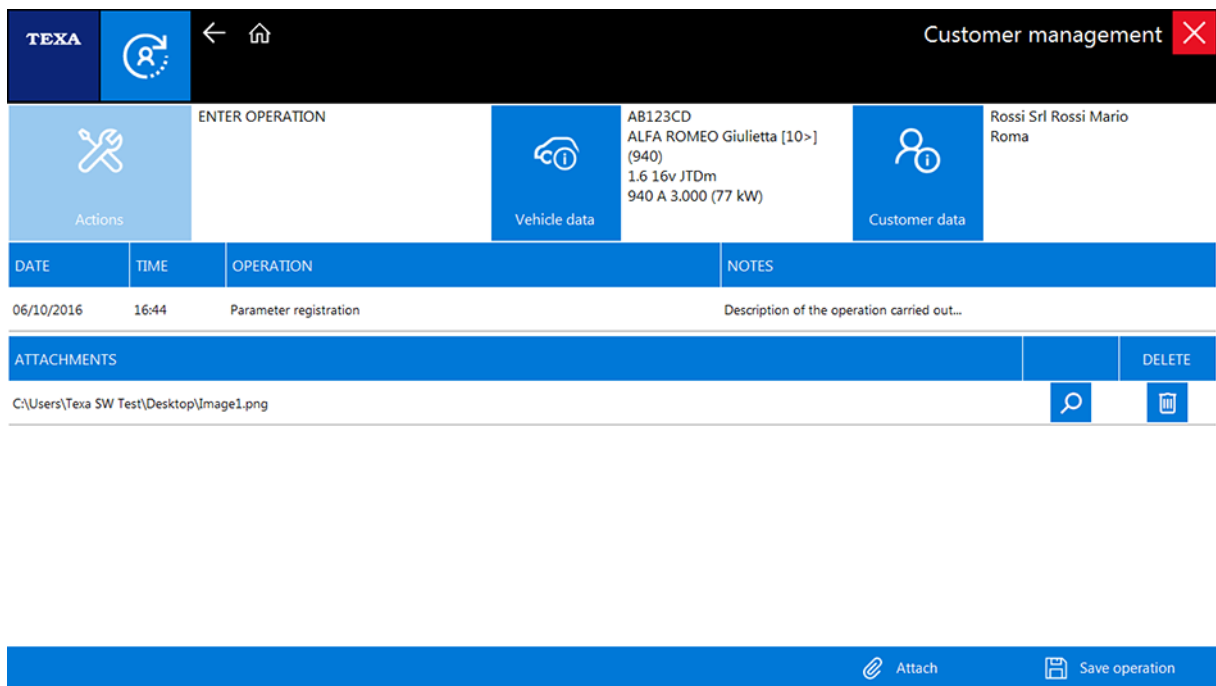
Proceed as follows:

1. Press: .
2. Enter the required information in the specific fields.
3. Press:  to save the action.
4. Press:  in the confirmation message.



Icon	Name	Description
	View	It allows you to view the attachment loaded.
	Delete	It allows you to delete the attachment loaded.
	Attach	It allows you to attach to the operation an image among the ones in the PC's folders.
	Save Operation	It allows you to save the changes made.

68.3 Vehicle Data

In this page you can change and save the information related to the vehicle associated to the customer selected.

Proceed as follows:

1. Press: **Vehicle Data**.
2. Change the desired information.

DATA		NOTES
License plate number*	AB123CD	
VIN	123456789	
Make	ALFA ROMEO	
Model	Giulietta [10>] (940)	
Registration date	06/10/2016	
Country of registration	ITALY	
Engine type	1.6 16v JTDm	
Engine code	940 A 3.000 (77 kW)	



Icon	Name	Description
	Select Vehicle from IDC5	It allows you to select a vehicle through Vehicle Selection .
	Save Vehicle	It allows you to save the changes made.

68.4 Client's Data

In this page you may change and save the information related to the selected customer.

Proceed as follows:

1. Press: **Customer Data**.
2. Change the desired information.

Icon	Name	Description
	Search Customer	It allows you to select a customer among the ones already entered. In this context, the function is useful if a vehicle was entered without being associated to a customer.
	Save Customer	It allows you to save the changes made.

69 REPORT REPOSITORY



This function allows accessing the folder in which the files in XML and PDF format are archived and exported from the Self-diagnosis and TGS3s functions.

Proceed as follows:

1. Press: 

The content of the folder is displayed.

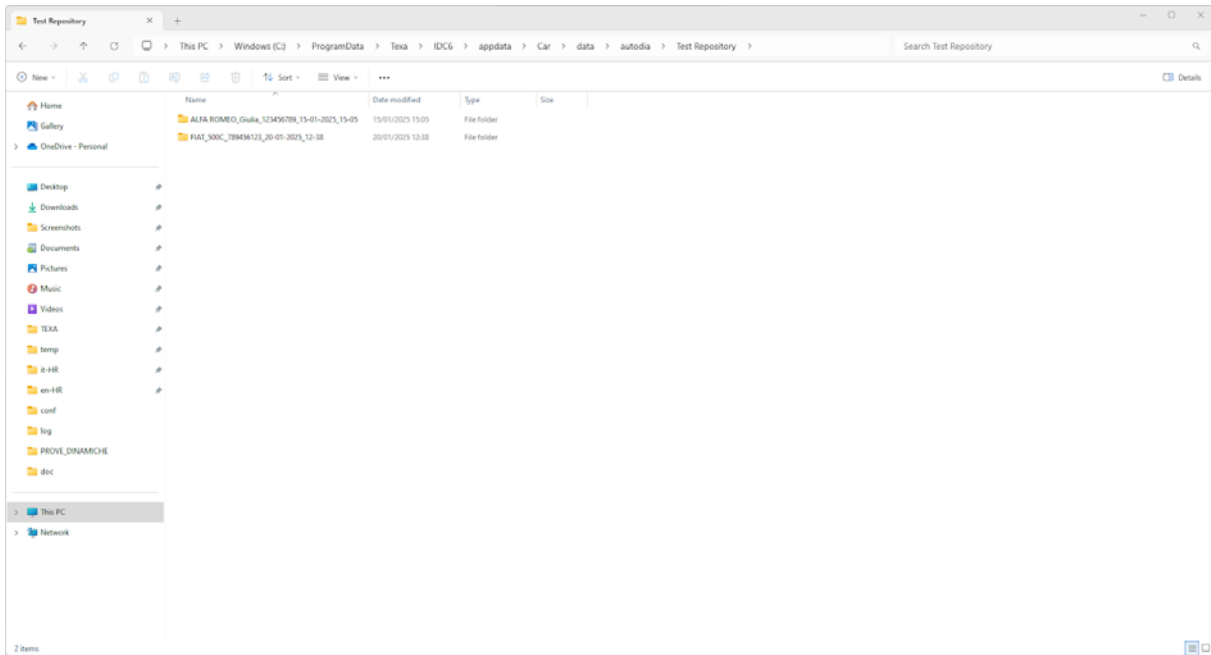

The subfolders are renamed using the data of the vehicles for which they collect the reports:

- *make;*
- *model;*
- *licence plate number.*

2. Press on the desired subfolder to view the stored reports.

70 EXCHANGE MANAGER



This function allows you to manage the control unit firmwares of particular systems (control units) of the vehicle being tested.

Thanks to this function, you can download, using Internet, firmwares provided by the manufacturer of the vehicle, save firmwares that are in the system and delete firmwares that are obsolete or no longer useful.

Proceed as follows:

1. Press:

2. Access the folder: **exmanager**

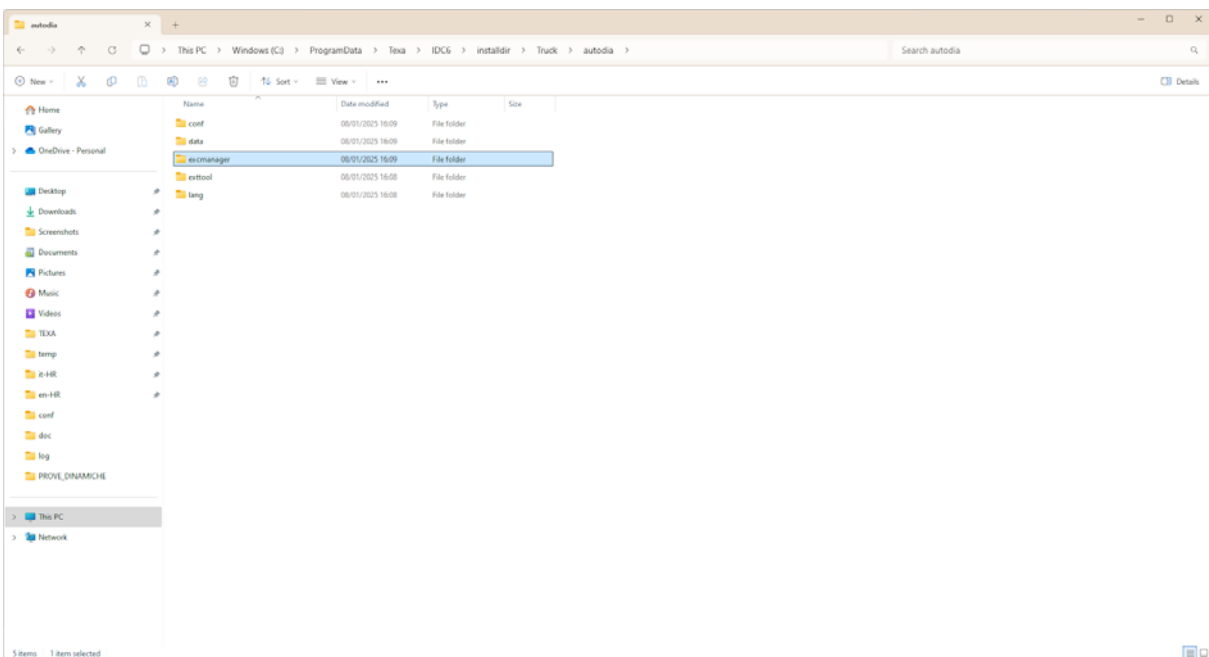

The following subfolders are displayed.

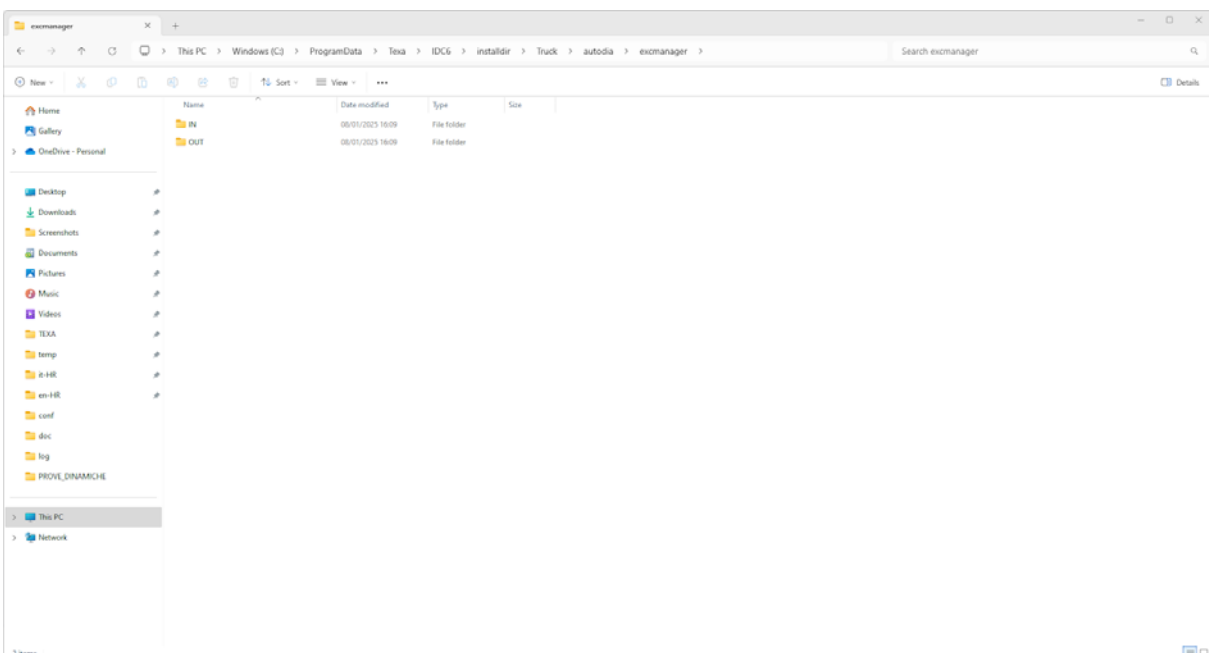

The firmwares downloaded using Internet are saved in the **IN** folder, while the firmwares that are in the diagnostic systems are saved in the **OUT** folder.

INFORMATION

The function is available from the operating system desktop using the

icon: 

71 BIKE / MARINE / TRUCK / OHM CABLES



This function allows accessing the database of the specific cables for the environment you are working in.

INFORMATION

You can always use the menus in the database to change:

- environment;
- reference geographical area;
- language.





NOTE: As an example, below you will find the database of the TRUCK environment cables.

Proceed as follows:

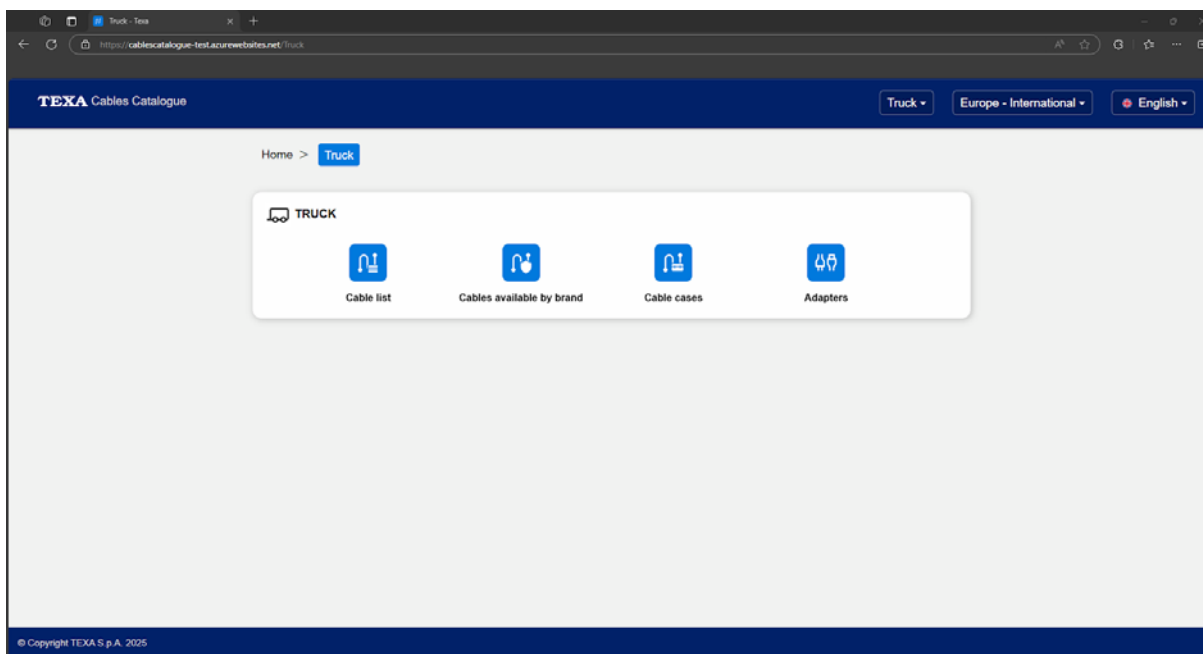
1. Press: 

The main screen of the database of the cables related to the environment you are working in is displayed.



Icon	Name	Description
	Cable list	It allows accessing the complete list of cables for the environment you are working in.
	Cables available by brand	It allows accessing the list of available cables divided by brand.
	Cable cases	It allows displaying the cable cases that can be associated with the environment you are working in.
	Adapters	It allows displaying the adapters that make the cables of the environment you are working in compatible with the VCIs used by other environments.

71.1 Cable List

This section allows accessing the complete list of cables for the environment you are working in. Proceed as follows:

1. Press: 

The list of cables is displayed.

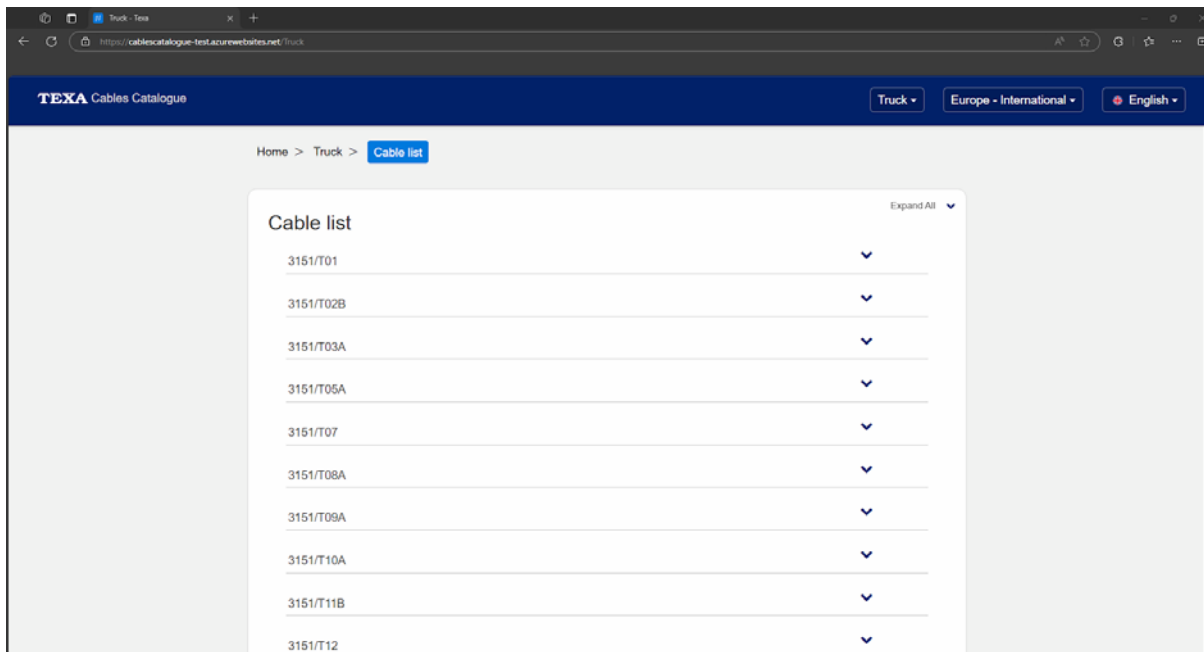

2. Press on the desired cable to display its description.

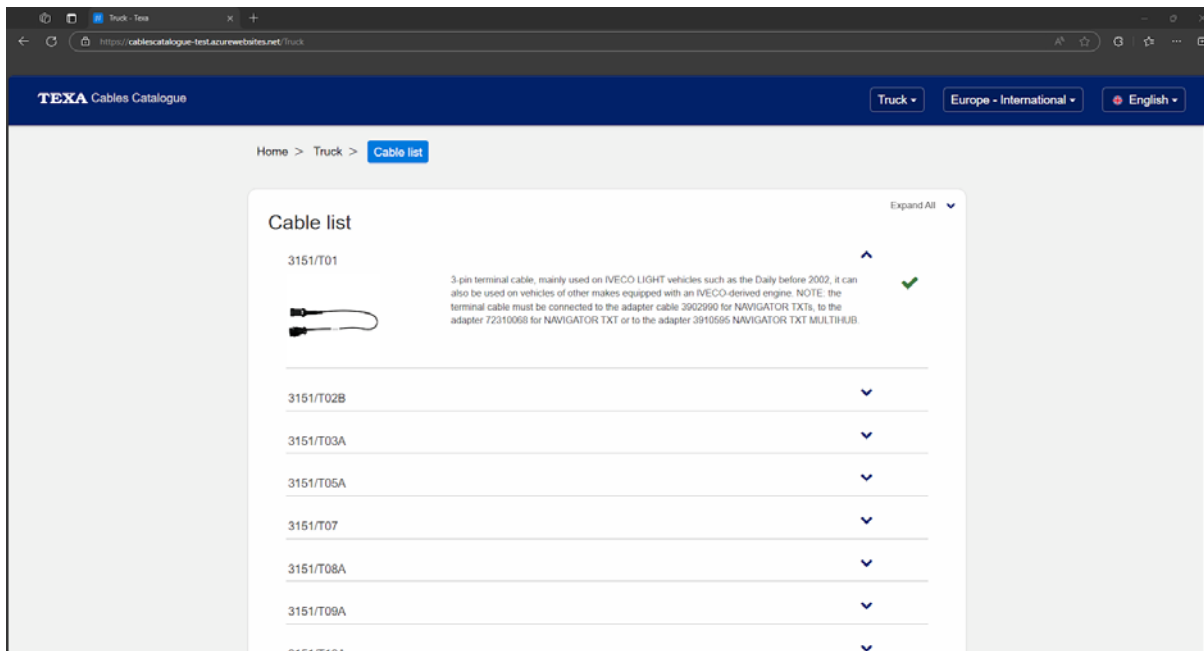

71.2 Cables Available by Brand

This section allows accessing the list of available cables divided by brand.

Proceed as follows:

1. Press: 

The list of the cables available by brand is displayed.

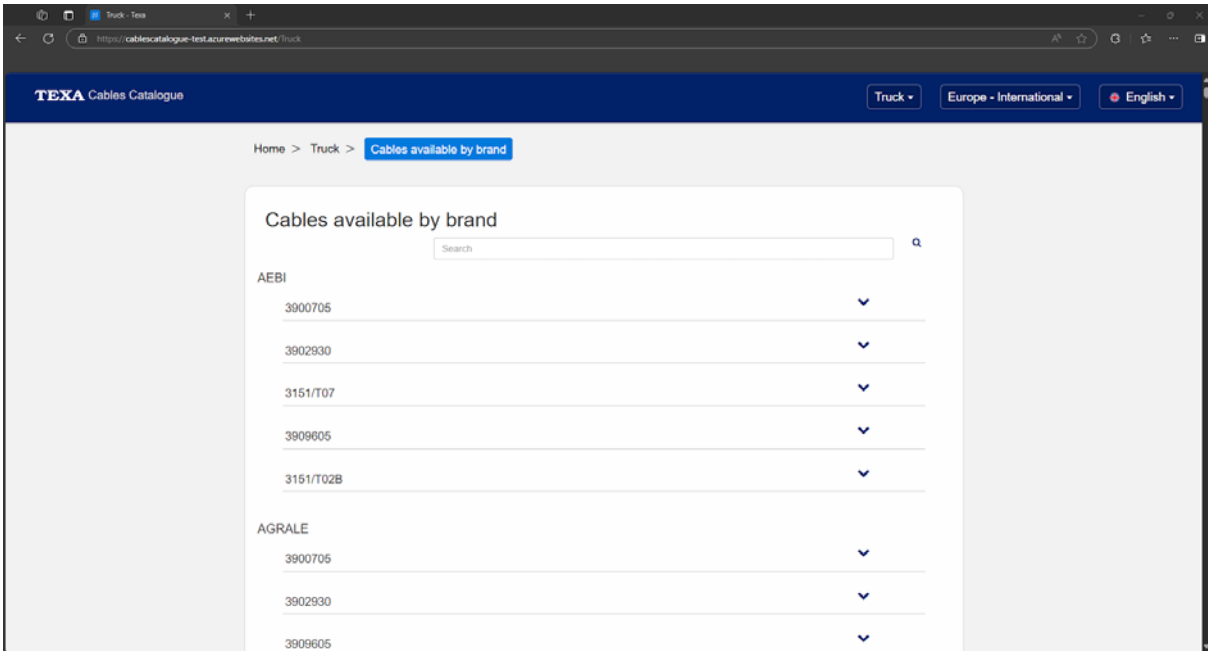

2. Press on the desired cable to display its description.

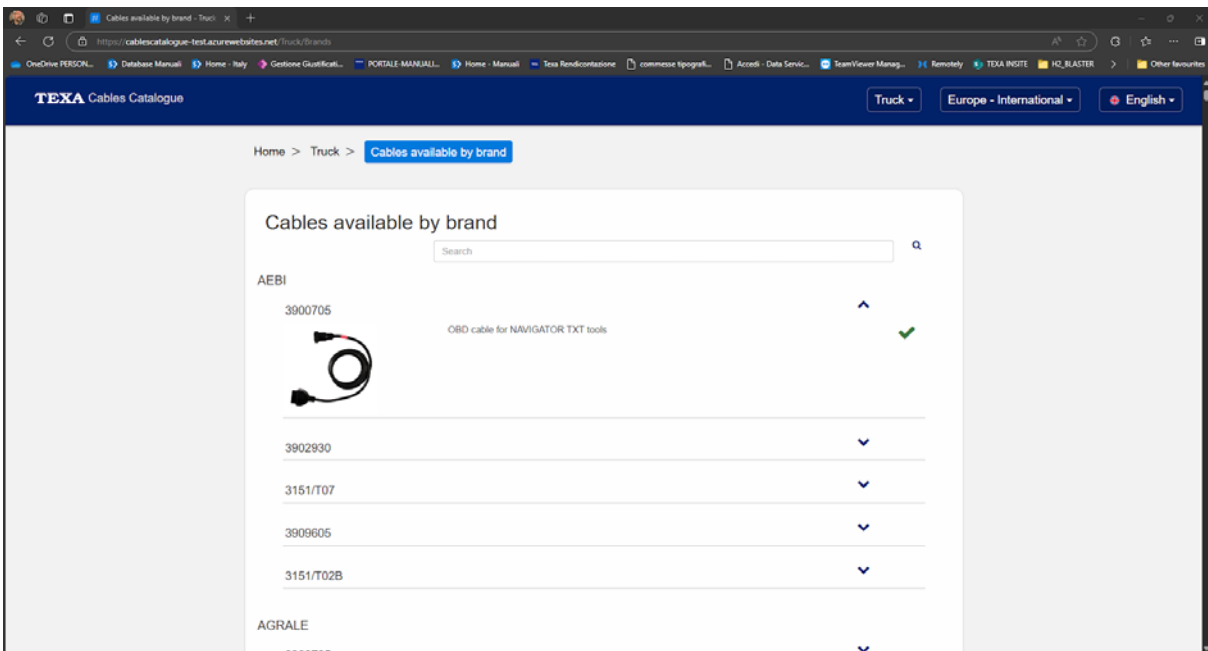

INFORMATION

You can enter the name of a vehicle brand in the free search files to automatically display all the cables it is associated with.

71.3 Cable Cases

This section allows displaying the cable cases that can be associated with the environment you are working in.

Proceed as follows:

1. Press: 

The list of the cable cases available by brand is displayed.

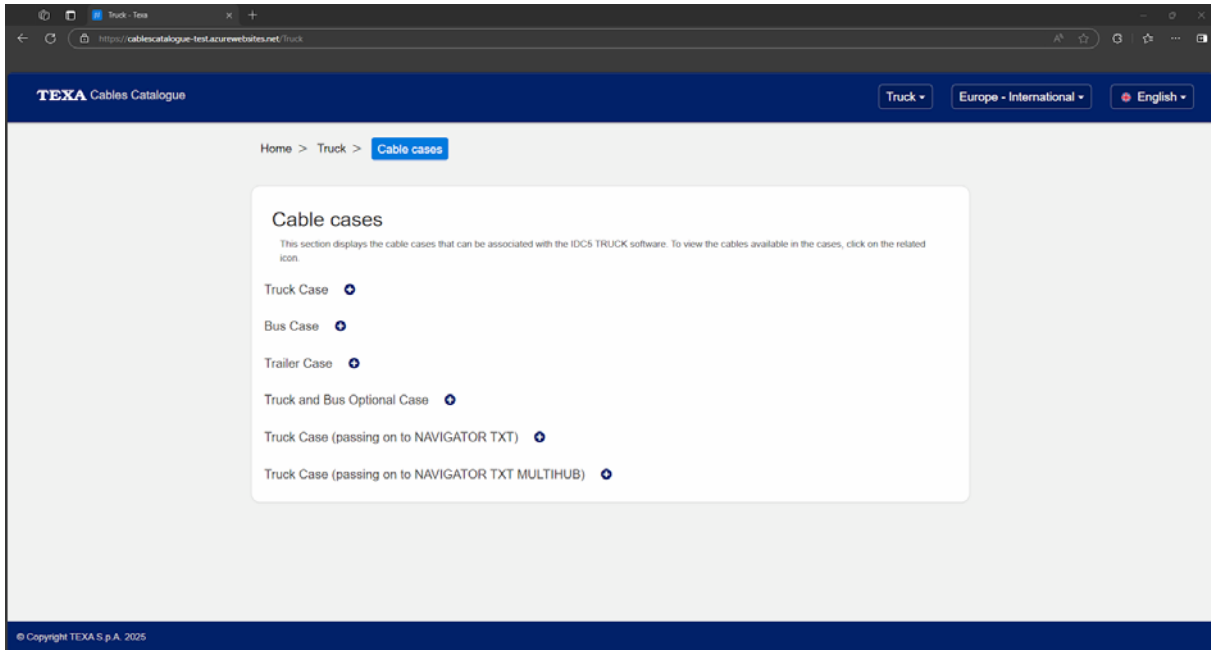

2. Press on the desired case to display its description.

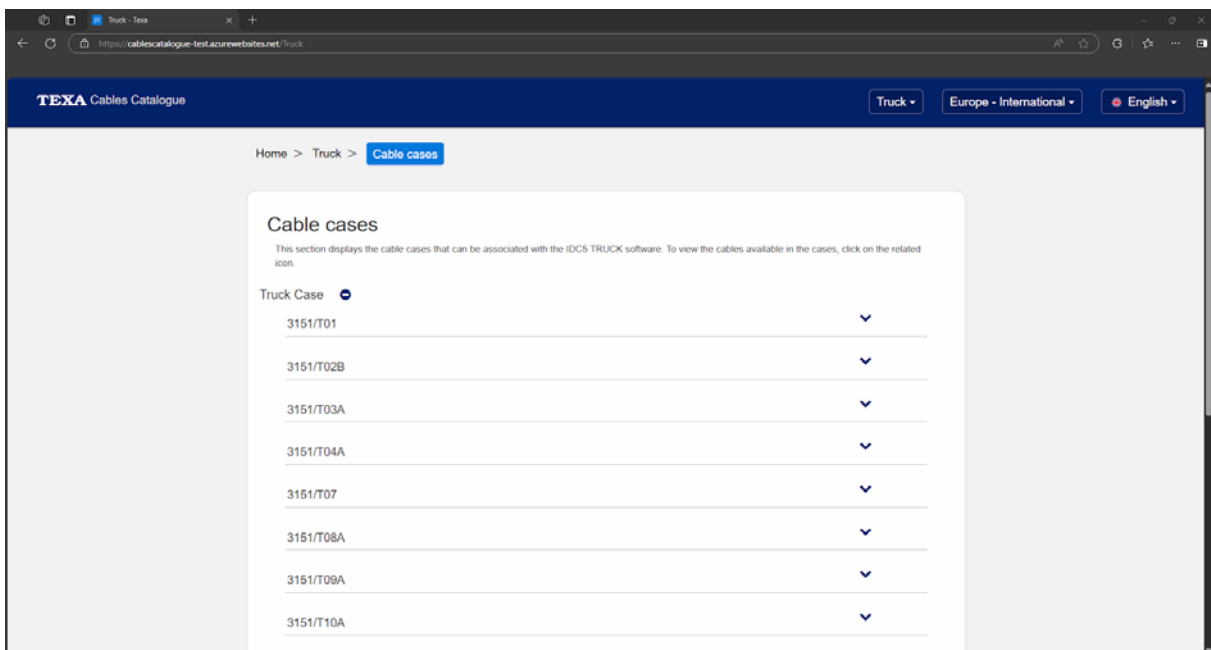

3. Press on the desired cable to display its description.

71.4 Adapters

This section allows displaying the adapters that make the cables of the environment you are working in compatible with the VCIs used by other environments.

Proceed as follows:

1. Press: 

The VCIs and related adapters are displayed.

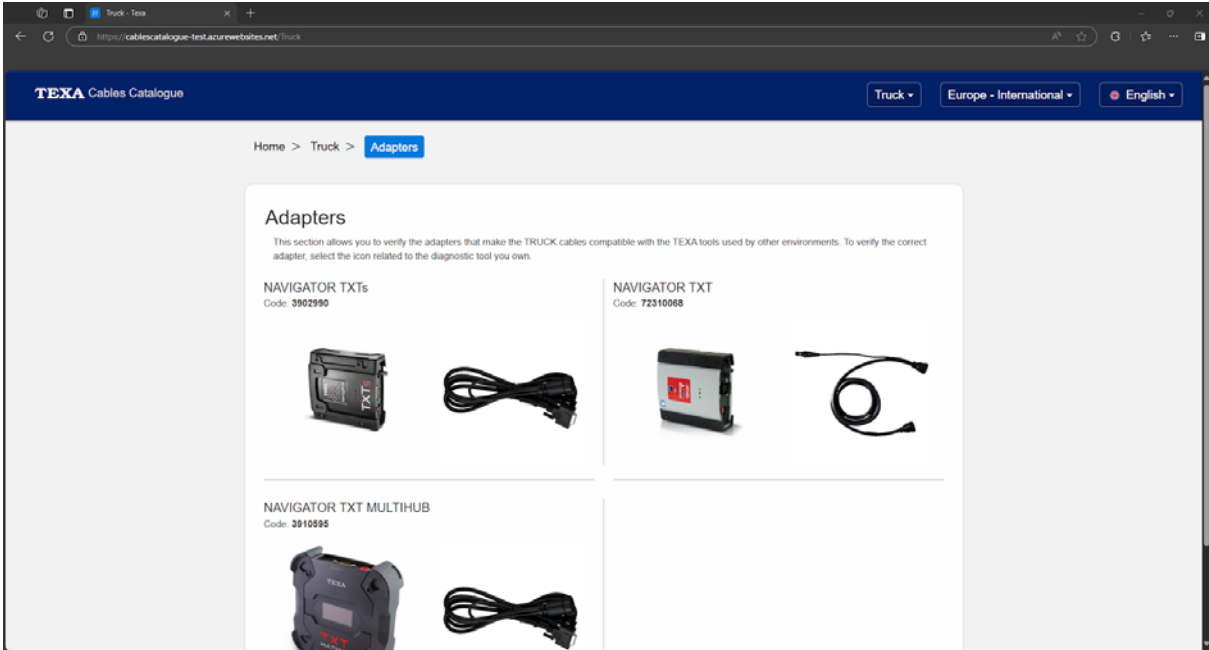

72 SUPPORT SECTION



This section gathers the support functions for the diagnosis and software use.

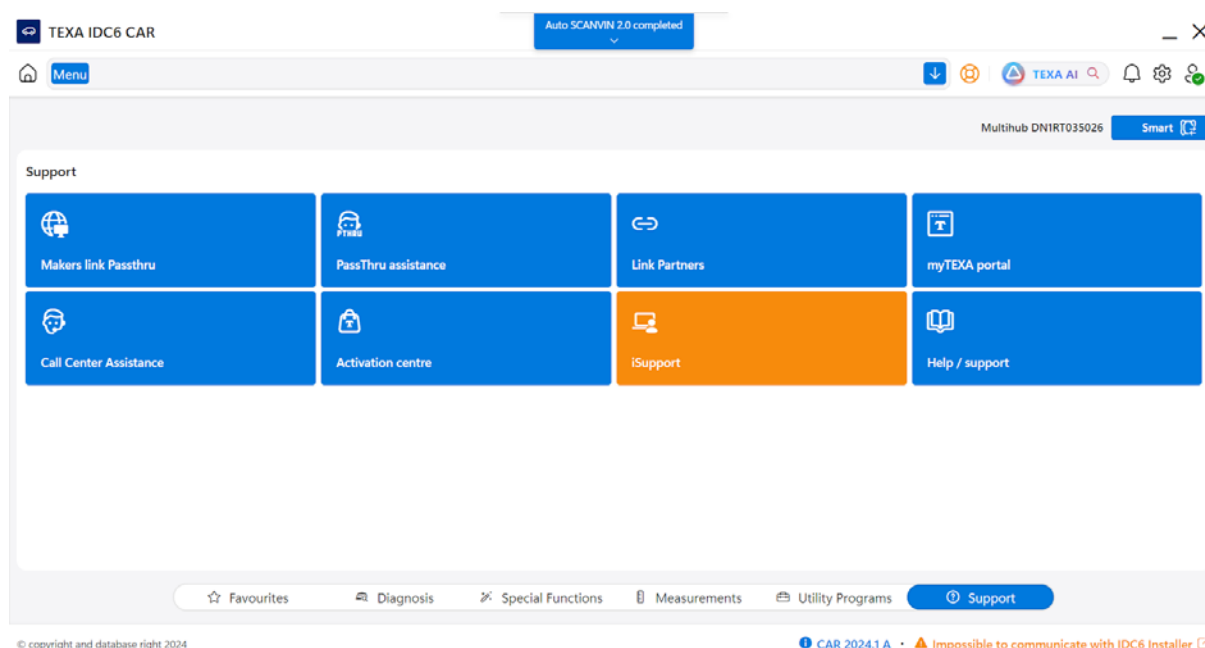

Icon	Name	Description
	PASSTHRU MANUFACTURERS' LINK	Allows to access the portal with the link to the manufacturers sites.
	PASSTHRU ASSISTANCE	It allows accessing the assistance portal for passthru diagnosis.
	PARTNERS' LINKS	It allows accessing the portal with the links to the TEXA partners' websites.
	myTEXA PORTAL	It allows accessing myTEXA, the portal dedicated to TEXA customers.
	CALL CENTER ASSISTANCE	It allows accessing the web portal for the Call Center assistance requests.
	ACTIVATION CENTRE	It allows accessing the web page with the list of purchased ACTIVATIONS and SERVICES.
	iSUPPORT	It allows you to access the on-line assistance function.
	HELP / SUPPORT	It allows you to access the documentation related to the selected environment.

INFORMATION

Some functions may not be available for all the environments or on all the platforms.

73 PASSTHRU



The Pass-Thru standards SAE J2534 and ISO 22900 aim at guaranteeing the possibility to carry out specific operations for control unit diagnosis and reprogramming using a third-party VCI, i.e. not proprietary to the vehicle manufacturer.

These operations are possible by using the VCI in combination with a specific software.

The VCI and the software must comply with the requirements of the Pass-Thru standards.

The software is distributed by the vehicle manufacturer through its website or a physical storage device.

INFORMATION

The activation date, the actual availability, the type, the cost and the procedures regarding the use of the Pass-Thru service(s) are specifically determined by each manufacturer; costs, performances and procedures may therefore vary independently of what TEXA S.p.A establishes.

Each manufacturer imposes specific hardware and operating system requirements for the PC where its software will be installed.

The PC must be generally equipped with the following:

- *Windows operating system;*
- *USB port;*
- *serial port;*
- *RJ45 port;*
- *Wi-Fi;*
- *access to the Internet.*

INFORMATION

Reprogramming or calibrating the control units may require you to download specific files from the vehicle manufacturer's website.

A high-speed connection to the Internet is highly recommended.

The vehicle manufacturer is entitled to request specific documentation to independent vehicle repairers (e.g.: Chamber of Commerce company registration showing that the company is actually registered in the register of vehicle repairers) so that they can carry out reprogramming operations on security systems (e.g.: immobiliser and/or antitheft control units).

The full compliance with the J2534-1 standard of the VCI that you purchased allows you to carry out operations using the diagnostic cable indicated by the software.

If operating on vehicles using the J2534-2 standard for the CAN Single Wire reprogramming, an optional cable may be required to connect to the **PV** connector.

During the reprogramming operations, it is essential that:

- *the vehicle's supply voltage remains constant throughout the operations; if necessary, use an external power adapter to charge the vehicle's battery;*
- *the vehicle's electrical system is efficient and working properly;*
- *the Internet connection is stable and suitable for the operations required;*
- *the instructions provided by the vehicle manufacturer are followed to the letter step by step.*

NOTICE

Reprogramming or calibrating the control units is an extremely delicate operation that may cause serious damage to persons or things if not performed properly.

Carefully follow the indications by the vehicle manufacturer for every aspect of the reprogramming procedure and in general for every operation in Pass-Thru.

INFORMATION

TEXA S.p.A. is not, under any circumstance, liable for repair and maintenance work carried out on vehicles using the Technical Information and/or Services offered by the specific websites of each manufacturer. In this respect, the use of Pass-Thru mode is subject to the acceptance of specific Liability regulations defined by each vehicle manufacturer.



For further information, please refer to the documentation provided by the vehicle manufacturer.

73.1 Passthru Manufacturers' Link

This function allows to access the portal with the link to the manufacturers sites.

Proceed as follows:

1. Press:  / **Passthru Manufacturers' Link**

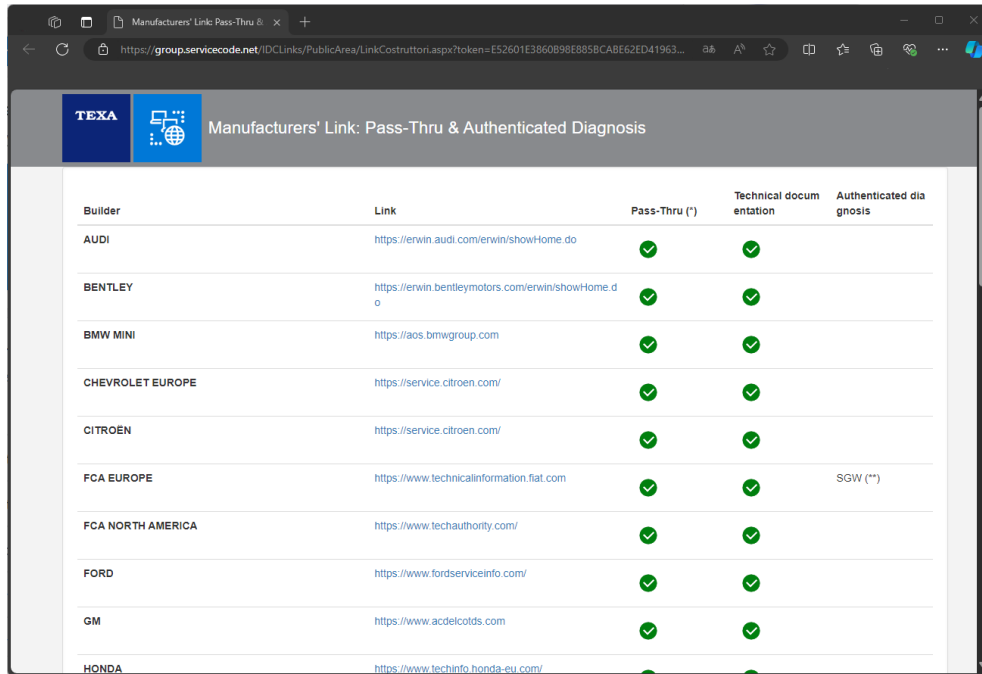

Builder	Link	Pass-Thru (*)	Technical documentation	Authenticated diagnosis
AUDI	https://erwin.audi.com/erwin/showHome.do	✓	✓	
BENTLEY	https://erwin.bentleymotors.com/erwin/showHome.do	✓	✓	
BMW MINI	https://aos.bmwgroup.com	✓	✓	
CHEVROLET EUROPE	https://service.citroen.com/	✓	✓	
CITROEN	https://service.citroen.com/	✓	✓	
FCA EUROPE	https://www.technicalinformation.fiat.com	✓	✓	SGW (**)
FCA NORTH AMERICA	https://www.techauthority.com/	✓	✓	
FORD	https://www.fordserviceinfo.com/	✓	✓	
GM	https://www.acdelcotds.com	✓	✓	
HONDA	https://www.techinfo.honda-eu.com/	✓	✓	

2. Click on the link of the desired manufacturer.
3. Follow the instructions provided by the manufacturer.

73.2 Passthru Assistance

This function allows accessing the assistance portal for passthru diagnosis.

INFORMATION

In order to use this function, you need to have a myTEXA account and enter your credentials when requested.

Proceed as follows:



1. Press: **Passthru Assistance**

2. Select the desired manufacturer

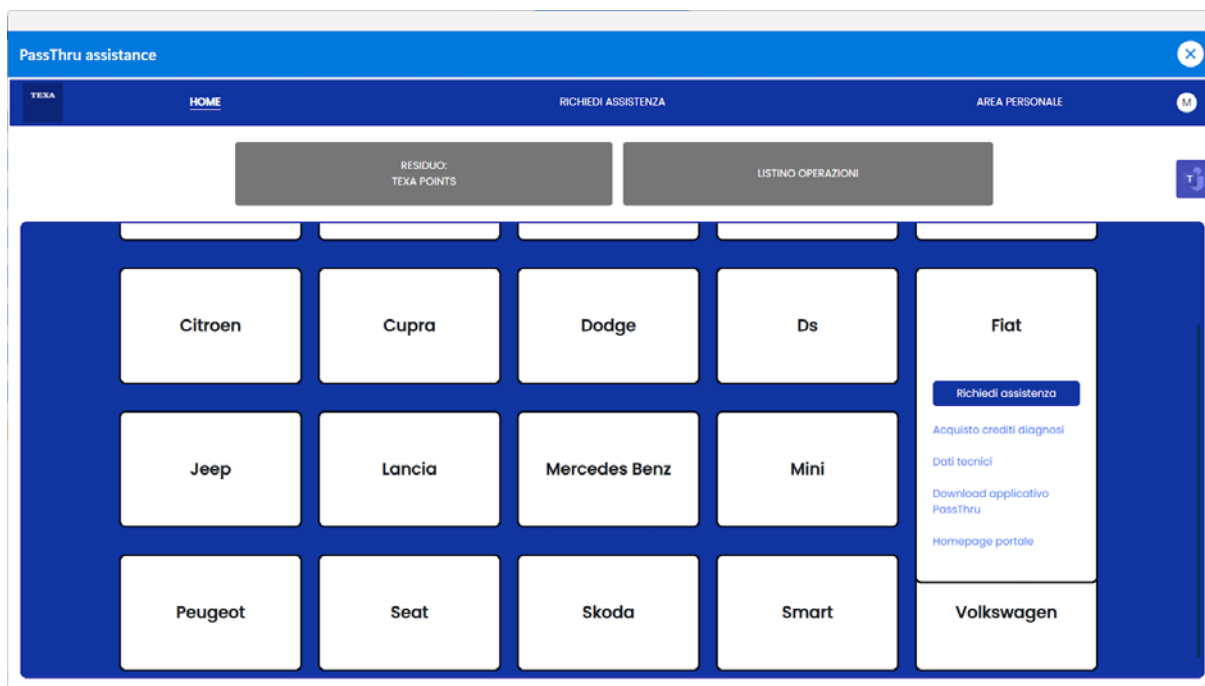

REMAINING TEXA POINTS	It indicates the number of remaining TEXA POINTS.
OPERATION LIST	<p>It allows you to:</p> <ul style="list-style-type: none"> • <i>view the history of requests, divided by Open and Closed tickets;</i> • <i>activate the Passthru Assistance service;</i> • <i>view the price list of the available operations (e.g.: Purchase of diagnostic credits);</i> • <i>purchase one of the available operations.</i>

3. Select the desired manufacturer

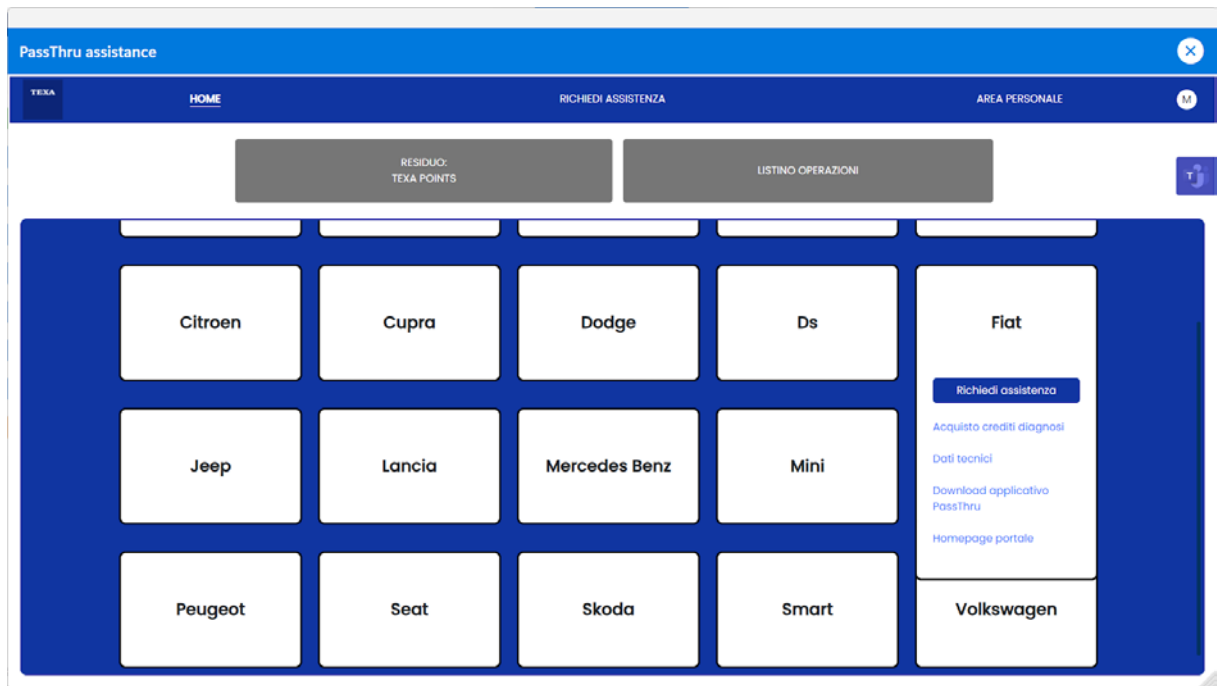

4. Select the desired operation.

74 PARTNERS' LINKS



This function allows accessing the portal with the links to the TEXA partners' websites. Proceed as follows:

1. Press: 

The portal's homepage is displayed.

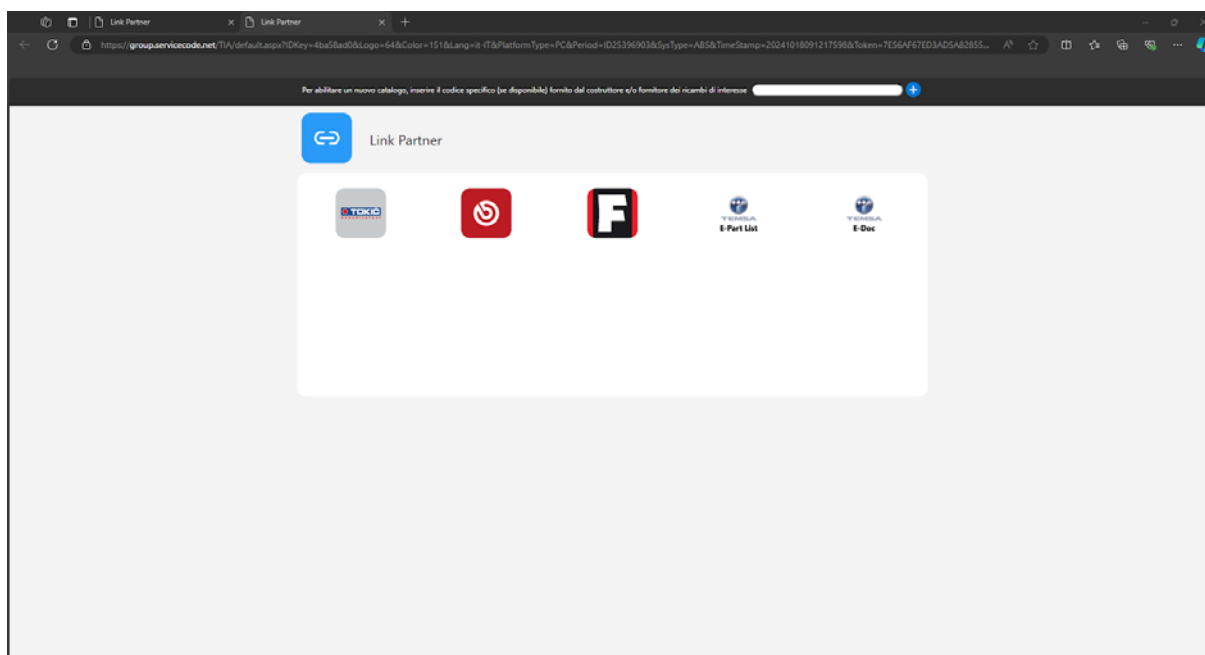

2. Press on the icon/logo of the desired TEXA partner.
The software automatically redirects to the selected partner's website.

75 myTEXA



This function allows accessing myTEXA, the portal dedicated to TEXA customers.

In myTEXA you can:

- *view your personal information;*
- *view the TEXA tools and devices purchased and activated;*
- *check the software for the tools and devices;*
- *check the active subscriptions and services.*

INFORMATION

In order to access the portal, you need to have a myTEXA account.

You must sign up to the portal to obtain your LOGIN data, entering the serial number of a TEXA tool or device you purchased and your TEXA ID.

To get your TEXA ID, contact your retailer.

If you have a VCI, your TEXA ID can also be found in the SETTINGS screen indicating the software version.

For further information, see the chapter: Software Information

Proceed as follows:

1. Press:

The portal is displayed.

myTEXA

myTEXA è il portale realizzato per permettere ai clienti TEXA di crearsi un profilo identificativo che consenta loro di accedere, anche al di fuori dell'officina, a tutti i servizi dedicati.

Tramite questo portale è innanzitutto possibile entrare, con un link, nell'area riservata di DOWNLOAD MANAGER, il nuovo applicativo sviluppato appositamente per semplificare, velocizzare e rendere ancora più protette le procedure di scaricamento dei software di diagnosi.

Sarà possibile, inoltre, iscriversi alla newsletter e ricevere sulla propria casella di posta selezionata tutte le ultime notizie relative all'azienda, ai suoi prodotti e relativi aggiornamenti ed upgrade, oltre al calendario corsi TEXAEDU e molto altro ancora.

Registrazione

Registrarsi è semplice e veloce e ti dà la possibilità di accedere a tutto ciò che riguarda il mondo TEXA.

REGISTRAZIONE HELP

Login

E-Mail

example@texa.com

Password

ENTRA

Privacy Recupera password Resetta Account

2. Enter your credentials.

3. Press: **ENTER**

The personal homepage of your account is displayed.

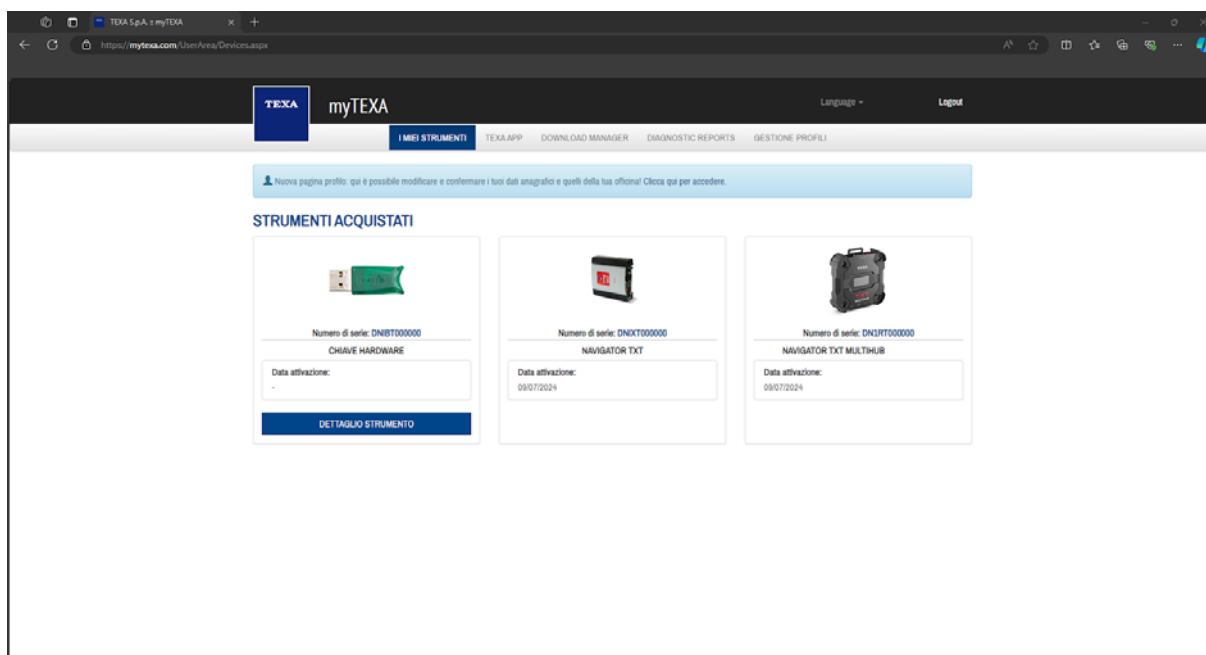

MY EQUIPMENT	It shows the list of purchased tools and hardware (HASP) keys, complete with serial number and activation date.
TEXA APP	It allows you to access TEXA's virtual store where you can request from your retailer the activation of additional applications.
DOWNLOAD MANAGER	It allows you to access the web page where you can download the DOWNLOAD MANAGER software.
DIAGNOSTIC REPORT	It allows you to access configurable dashboards that are available in a graphic or table format.
PROFILE MANAGEMENT	It allows accessing the workshop employee profile management page.

INFORMATION

HARDWARE KEY

Press: EQUIPMENT DETAIL

The complete list of the following purchased items is displayed:

- *environments*
- *apps / services*
- *subscriptions*

These items are linked to the specific hardware key selected.

75.1 Diagnostic Reports



The service allows you to access configurable dashboards that are available in a graphic or table format.

You can view the data directly through the dashboard or create a periodic report containing all the summarised data.

The report is automatically sent to the e-mail address indicated in the company details.

The dashboards available in **Diagnostic Reports** are:

- *general report of diagnoses;*
- *diagnosis by system;*
- *adjustments performed by system;*
- *operator activity;*
- *diagnosis by brand;*
- *DTCs detected by system.*

75.1.1 Dashboard configuration through filters

The dashboards can be filtered, from the "**Filter settings**" area, by:

- *environment;*
- *serial number;*
- *reference period.*

The drop-down menus allow setting the filters for the dashboard configuration.

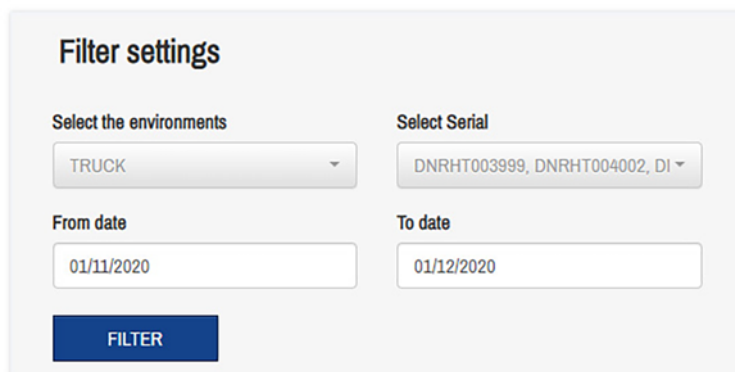

Filter settings

Select the environments: TRUCK

Select Serial: DNRHT003999, DNRHT004002, DI

From date: 01/11/2020

To date: 01/12/2020

FILTER

75.1.2 Periodic report scheduling

It is possible to activate the periodic generation of a report, which can then be sent via e-mail.

Periodic report scheduling

E-Mail	Document format
<input type="text" value="example@domain.com"/>	<input type="text" value="Excel"/>
How often (gg)	
<input type="text" value="1"/>	
<input type="button" value="SAVE"/>	<input type="button" value="DELETE"/>

Proceed as follows:

1. Enter the e-mail address to which you wish to send the report in the specific field in the "**Periodic report scheduling**" area.
2. Select the frequency and document format.
3. Press **SAVE**.

75.1.3 General report of diagnoses

This dashboard allows you to view information on the diagnostic scans performed and the related errors.

The data can be viewed in a graphic or table format.

GENERAL REPORT OF THE DIAGNOSES IN GRAPHIC FORMAT

The graphic format displays the total number of control unit scans performed and the number of errors detected for each day.

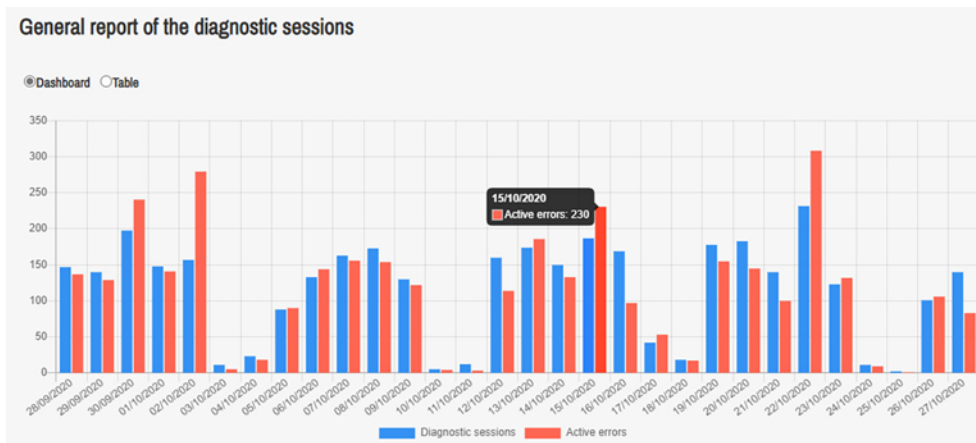

By pressing on the legend under the chart, you can activate or deactivate the categories represented.

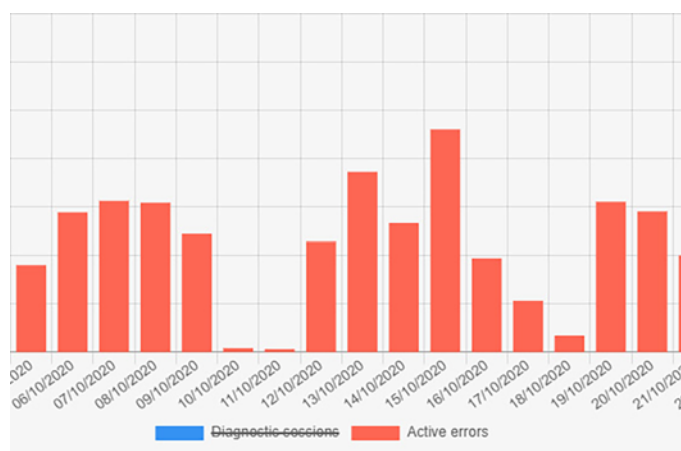

When moving the mouse cursor over each column, a label appears indicating the date and number of scans performed or the active errors in the scans performed.

GENERAL REPORT OF THE DIAGNOSES IN TABLE FORMAT

General report of the diagnostic sessions

Dashboard Table

Date	Number of diagnostic sessions	Number of errors	Number of active errors	Number of stored errors	Average of active errors per diagnosis
10/10/2020	5	36	4	32	0.80
11/10/2020	12	45	3	42	0.25
12/10/2020	160	428	114	314	0.71
13/10/2020	174	364	186	178	1.07
14/10/2020	150	318	133	185	0.89
15/10/2020	187	471	230	241	1.23

Showing 13 to 18 of 30 rows

◀ 1 2 3 4 5 ▶

The table format displays:

- *the scans performed;*
- *the total number of errors (sum of active and stored errors);*
- *the active errors;*
- *the stored errors;*
- *the ratio between the scans performed and the number of active errors.*

75.1.4 Diagnosis by system

This dashboard shows the performed diagnoses in a graphic format, divided by system type, for the selected period of time and tools.

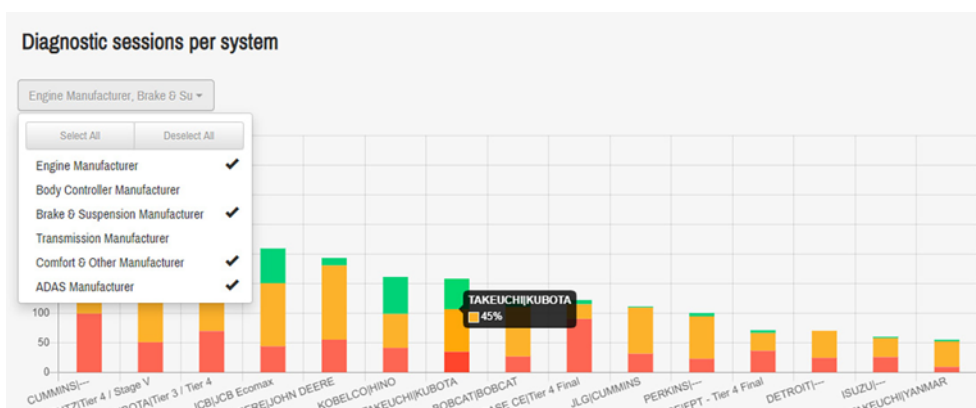

The bars in the chart are in decreasing order, from the highest to the lowest value, and show the total number of performed diagnoses divided by make and engine.

The colours in each bar indicate the detected errors in percentage.

- red: the active errors;
- orange: the stored errors;
- green: no errors detected.

The dashboard can be configured with six types of categories available.

Proceed as follows:

1. Press on the top left drop-down menu.
2. Select the desired category.

By pressing on the legend under the chart, you can activate or deactivate the categories represented.

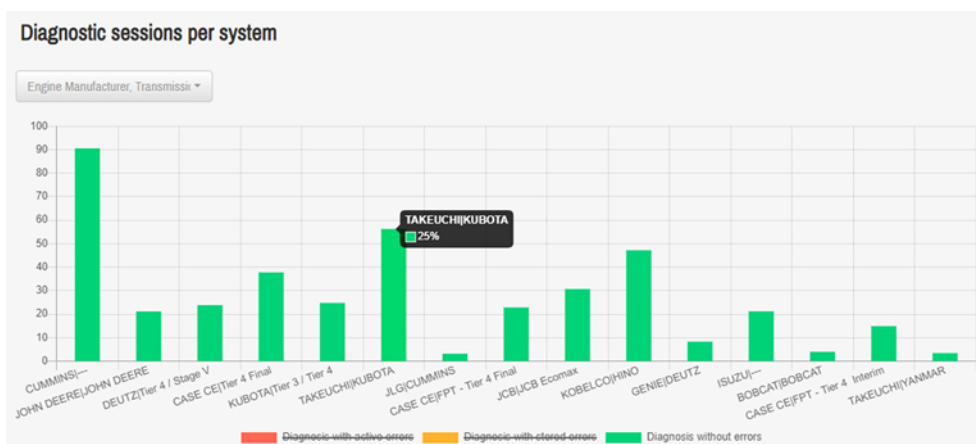

When moving the mouse cursor over each column, a label appears indicating the error type and the manufacturer.

Moreover, clicking on a single bar allows viewing the details of each system.

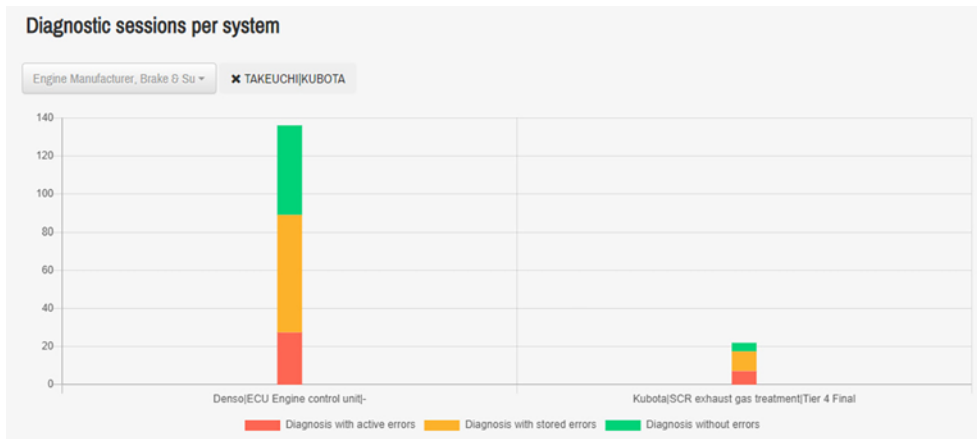

75.1.5 Operator Activity

The function allows associating a specific operator to each diagnostic session.

The function is automatically enabled by the system.

To check if the function is active or deactivate it, proceed as follows:

1. From the **Environment Settings** menu, press  .

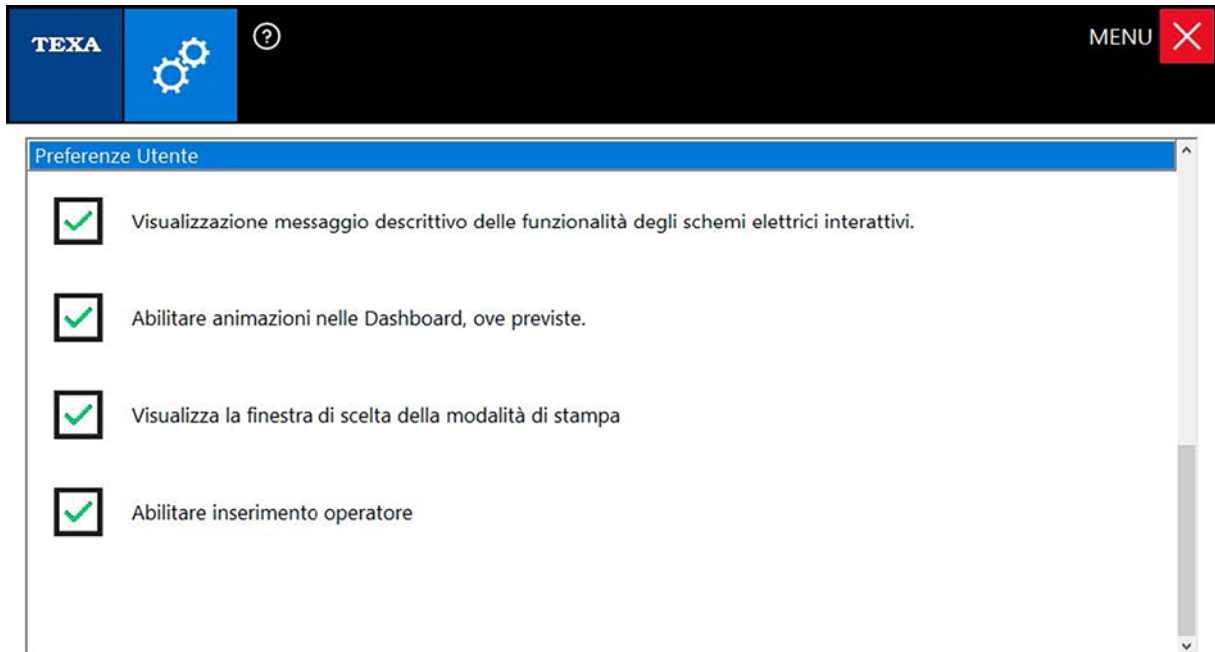

2. Select "Enable operator entry".

This dashboard displays, for each operator:

- *the total number of scans by system;*
- *the diagnoses performed with **TGS3s**;*
- *the adjustments performed.*

Proceed as follows:

1. From the top left drop-down menu, select the type of operation to display.

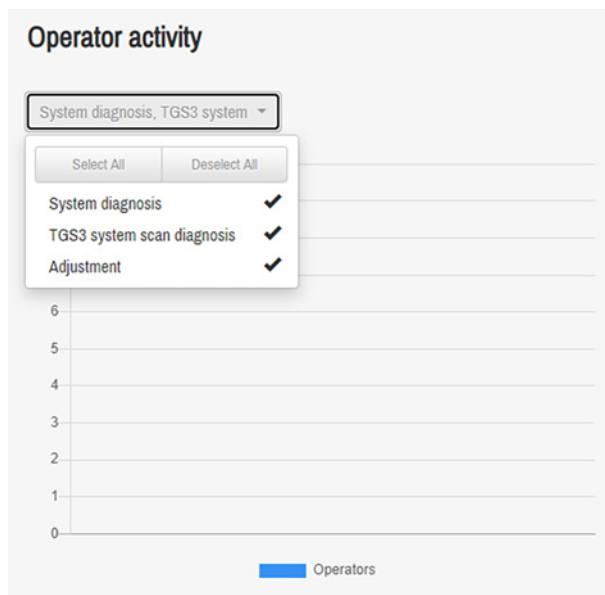

76 CALL CENTER ASSISTANCE



This function allows accessing the web portal for assistance requests to the Call Center.

Through the portal you can open a request for remote technical support and get in touch directly with a TEXA operator.

Proceed as follows:

1. Press:

The web portal for assistance requests to the Call Center is displayed.

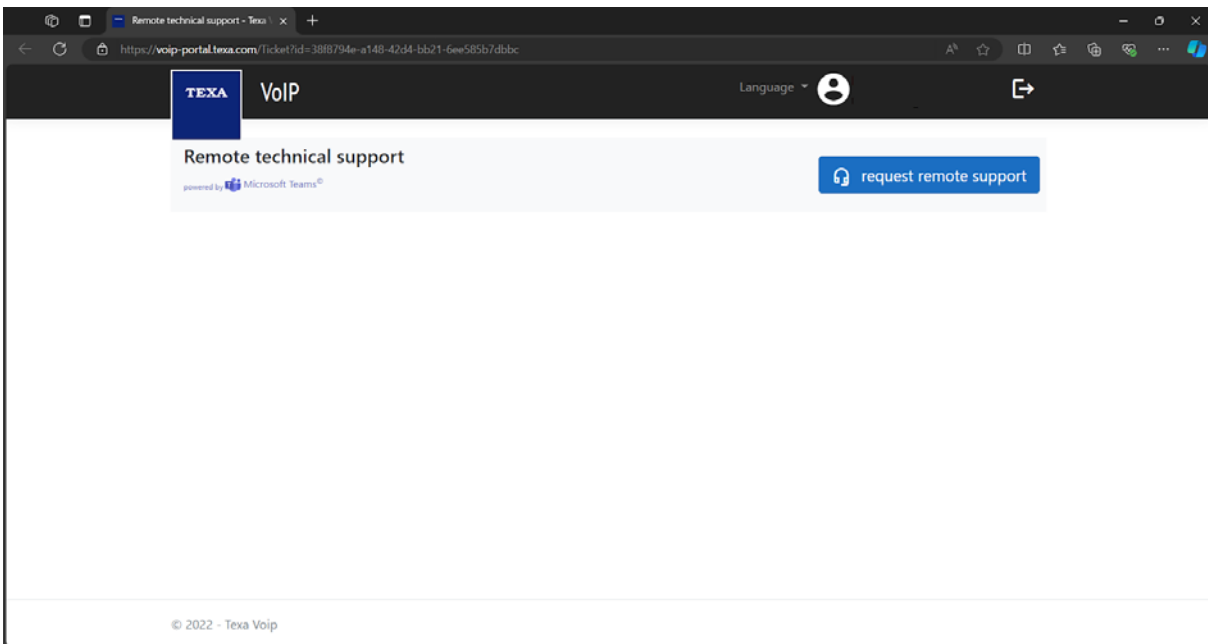

2. Press: **Request remote support**
3. Follow the instructions that appear on screen.

77 ACTIVATION CENTRE



This function allows accessing the web page with the list of purchased ACTIVATIONS and SERVICES.

The function allows you to send an installation request to your retailer.

Proceed as follows:

1. Press: 

The page is displayed.

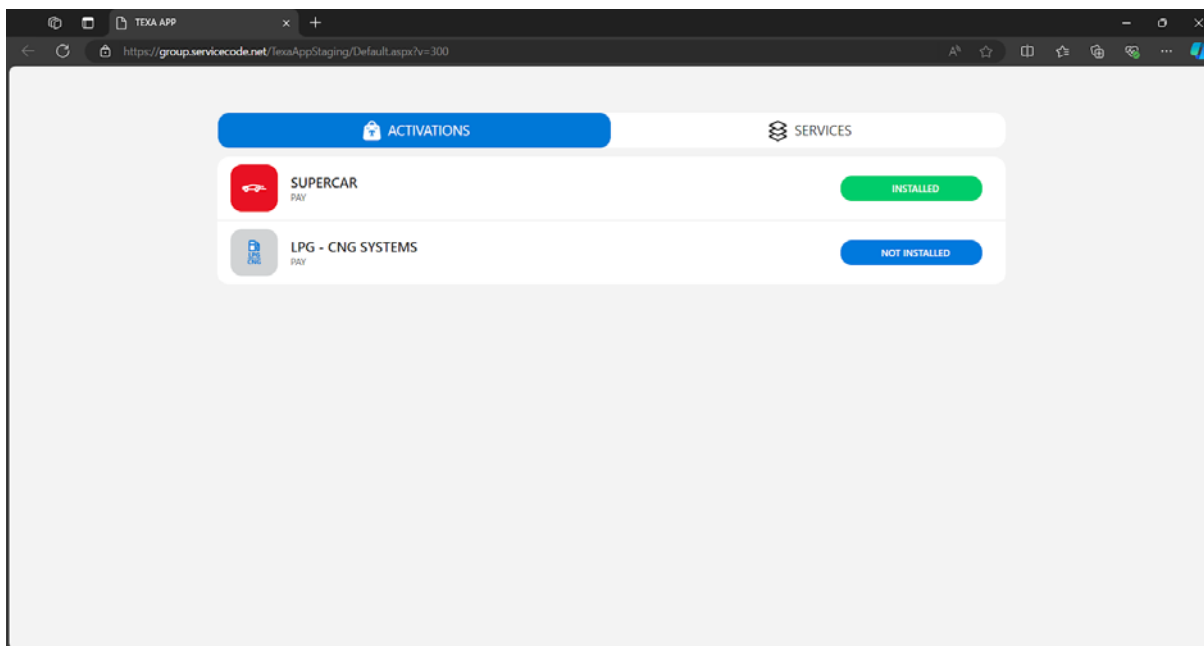

The page is divided in the following sections:

ACTIVATIONS	It gathers all the additional software functions that can be purchased for the current environment.
SERVICES	It gathers all the subscriptions to additional services that can be purchased for the current environment.

For each item in each section, the status is indicated:

- NOT INSTALLED
- TO BE INSTALLED
- INSTALLED

77.1 Installation of an ACTIVATION or a SERVICE

You can request the installation of an ACTIVATION or a SERVICE among the ones available for the current environment.

Proceed as follows:

1. Press on the desired section.
2. Press on the desired item.

A descriptive tab is displayed that summarises the particular functions of the selected item.

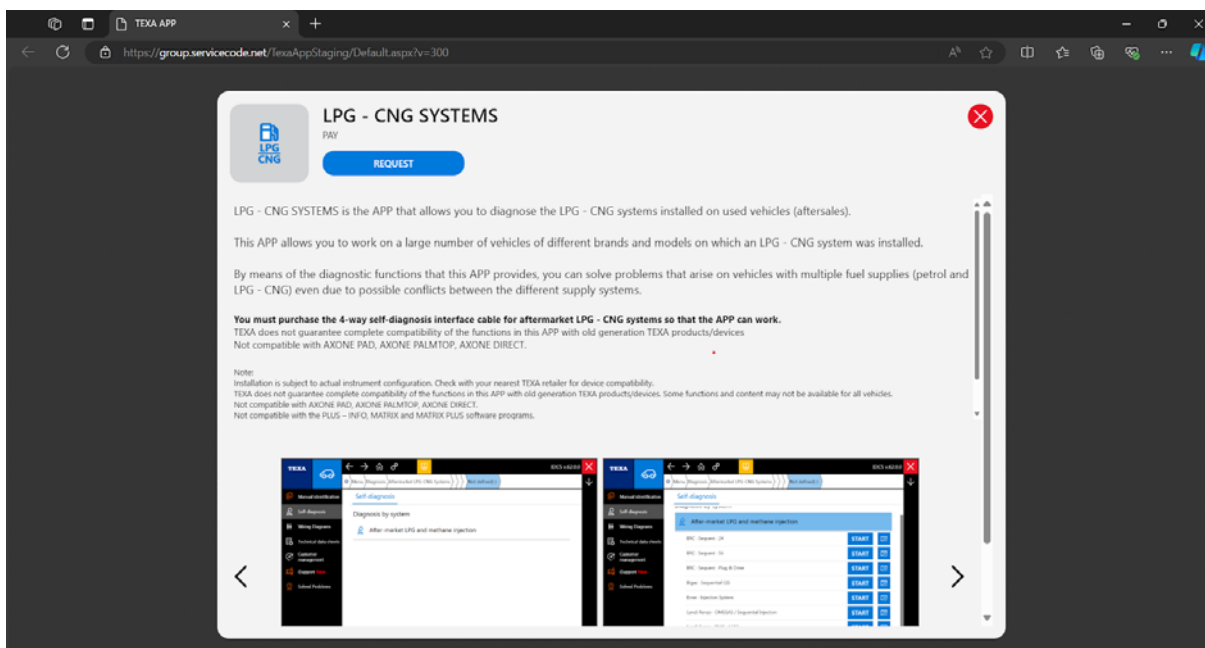

3. Press: **REQUEST**

The installation request is sent to your retailer.

Once the ACTIVATION or SERVICE has been purchased, its status changes from "NOT INSTALLED" to "TO BE INSTALLED".

4. Press on the desired item.
5. Accept the conditions of use.

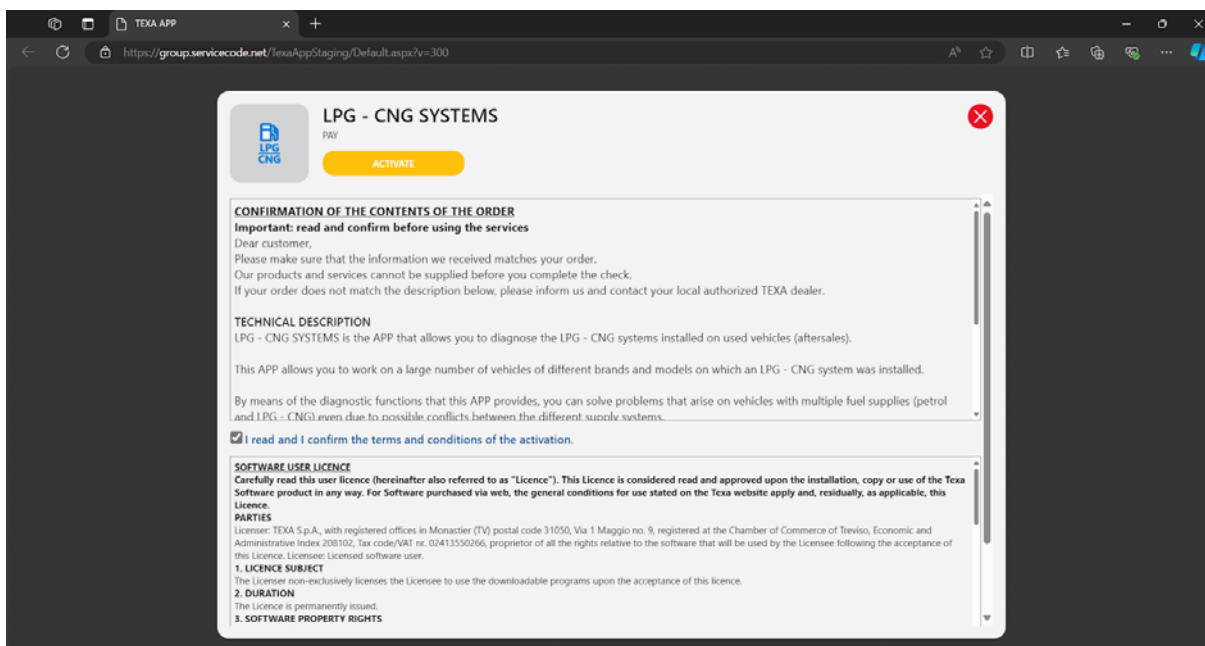

6. Press:**ACTIVATE**

7. Follow the instructions that appear on screen.

The status changes from "TO BE INSTALLED" to "INSTALLED".

78 iSUPPORT



This function allows you to:

- request technical support directly from the software;
- request the development of new self-diagnostic resources (special selections or functions that are not in the software).

Proceed as follows:

1. Press:

The main screen of **iSupport** is displayed.

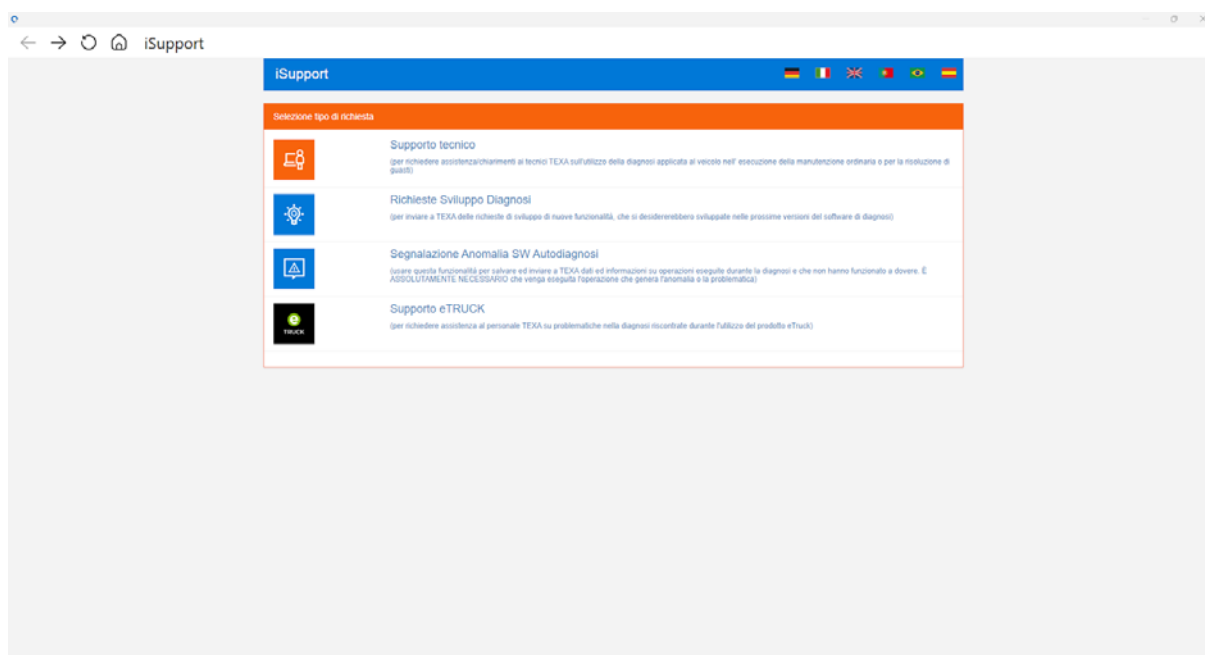

Icon	Name	Description
	Technical Support	It allows you to send a request form for assistance from TEXA technicians related to the diagnosis you are performing. It can be launched only after selecting a system.
	Diagnosis Development Requests	It allows sending a request form for the development of new self-diagnostic contents that are not in the software.
	Self-diagnosis SW fault notification	It allows sending data and information on operations carried out during the diagnosis but not successful. You must repeat the operation that generates the fault or problem.
	eTRUCK Support	It allows requesting the assistance of TEXA personnel for problems in the diagnosis encountered while using eTRUCK.

78.1 Technical Support

This function allows you to send a request form for assistance from TEXA technicians related to the diagnosis you are performing.

INFORMATION

The function can be launched only after selecting a system.

In order to favour a quick and useful response:

- *Make sure you have properly selected the vehicle and the system being tested.*
- *Thoroughly indicate the information regarding the vehicle's identification, the detected symptoms, the errors stored by the system, the tests you performed and the components that have already been replaced.*

Proceed as follows:

1. Press: 
2. Fill out the form with all the information required:
 - **Year:** year of the vehicle's first registration;*
 - **VIN:** vehicle's identification number;
 - **Errors:** errors detected during the diagnosis (indicate the error code and description);
 - **Problem Description.** *

(*) Mandatory field.

You can complete the request by attaching the documentation you believe necessary using the icon **Browse**.

3. Press: **Send**

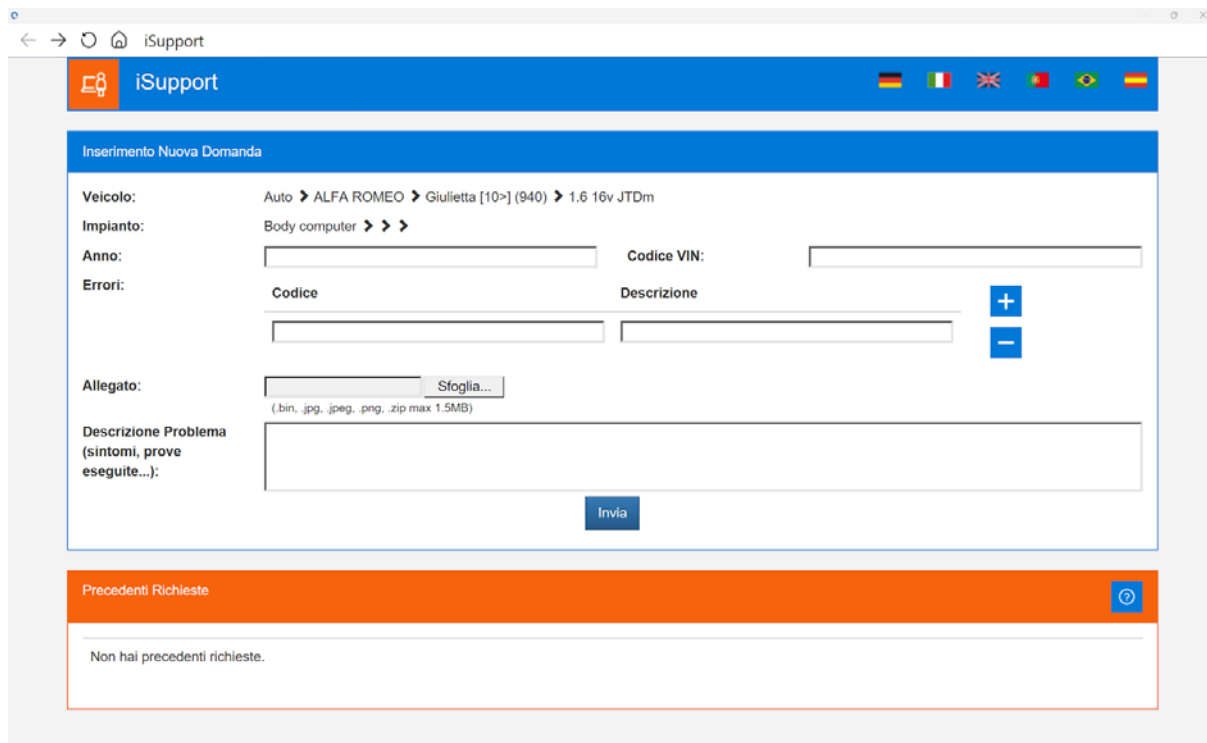

The screenshot shows a web browser window with the URL 'iSupport'. The page title is 'iSupport' and it features a blue header with a user icon and several language flags (Germany, Italy, UK, France, Brazil, Spain). The main content area is titled 'Inserimento Nuova Domanda' and contains a form with the following fields:

- Veicolo:** Auto > ALFA ROMEO > Giulietta [10>] (940) > 1.6 16v JTDm
- Impianto:** Body computer > > >
- Anno:** [Text input field]
- Codice VIN:** [Text input field]
- Errori:** A table with columns 'Codice' and 'Descrizione'. It has a '+' button to add rows and a '-' button to remove rows.
- Allegato:** [Text input field] with a 'Sfoglia...' button. Below it, the text '(bin, .jpg, .jpeg, .png, .zip max 1.5MB)' is displayed.
- Descrizione Problema (sintomi, prove eseguite...):** [Large text area]

At the bottom of the form is a blue 'Invia' button. Below the form is an orange bar with the text 'Precedenti Richieste' and a refresh icon. The content below this bar is empty, with the text 'Non hai precedenti richieste.'

INFORMATION

In case an error code has been entered, before sending the assistance request to the technicians, the software launches the Solved Problems function with the fields related to the vehicle already filled out (if available) and the entered error code.

This allows you to find an immediate solution through TEXA's solved problems database.

4. Press:



if a solution was found using **Solved Problems**.



if you want to continue and send the support request.



The request for assistance has been sent.

5. Access the **Technical Support** function again through .

6. Press **Select** on the desired request.

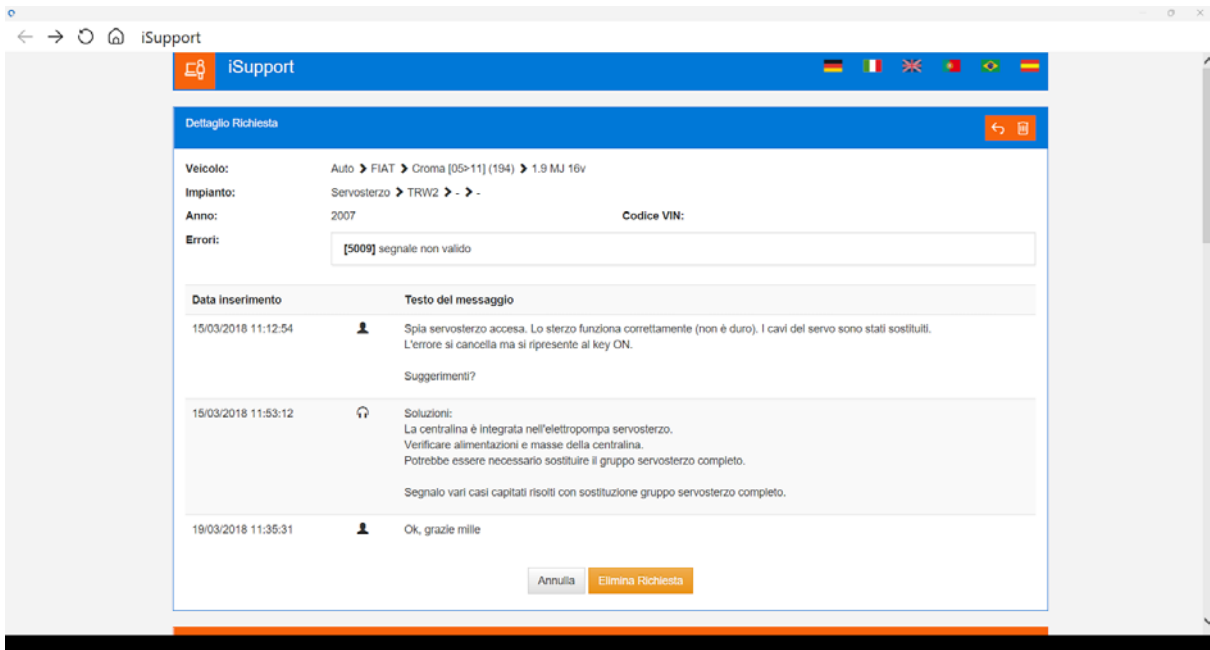
The screen with the answer given by the TEXA technician is displayed.



Icon	Name	Description
	answer	It allows answering or requesting further information to the TEXA technician.
	Delete	It allows deleting the request if the answer by the TEXA technician is satisfactory.

78.2 Diagnosis Development Requests

This function allows sending a request form for the development of new self-diagnostic contents that are not in the software.

It is important that you perform all the selections as completely as possible so the notification can be as efficient as possible.

Example: a notification regarding a missing adjustment must be filed after you have selected the vehicle and the self-diagnosis system the adjustment refers to.

Proceed as follows:

1. Press: 

2. Fill out the form with all the information required:

- **VIN:** *vehicle's identification number;*
- **description of the problem;** *
- **select the type of development required choosing among the ones suggested ones:** *
 - *service reset;*
 - *electrical diagrams or mechanical data;*
 - *adjustment / activation on a diagnostic system that already exists;*
 - *diagnosis for missing models;*
 - *diagnostic system for a model that already exists;*

(*) Mandatory field.

You can complete the request by attaching the documentation you believe necessary using the icon **Browse**.

3. Press: **Send**

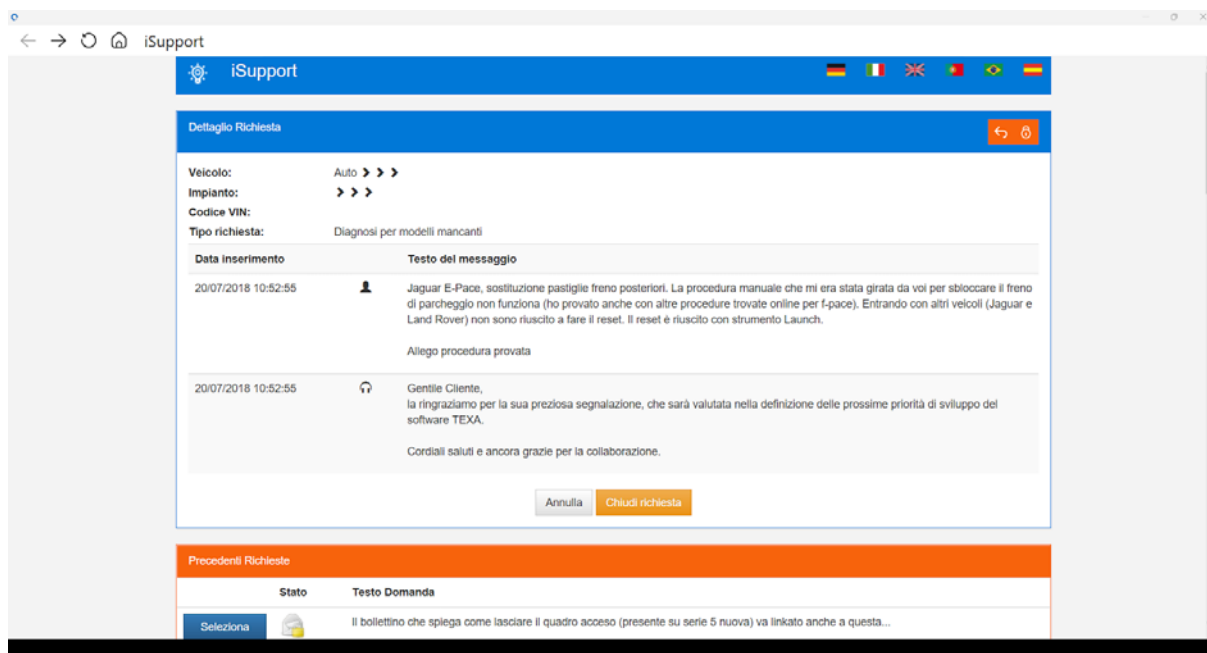

The screenshot shows the iSupport web interface. The main content area is titled 'Dettaglio Richiesta' and contains the following information:

- Veicolo:** Auto >>>
- Impianto:** >>>
- Codice VIN:** >>>
- Tipo richiesta:** Diagnosi per modelli mancanti

Below this is a table with two columns: 'Data inserimento' and 'Testo del messaggio'.

Data inserimento	Testo del messaggio
20/07/2018 10:52:55	<p>Jaguar E-Pace, sostituzione pastiglie freno posteriori. La procedura manuale che mi era stata girata da voi per sbloccare il freno di parcheggio non funziona (ho provato anche con altre procedure trovate online per f-pace). Entrando con altri veicoli (Jaguar e Land Rover) non sono riuscito a fare il reset. Il reset è riuscito con strumento Launch.</p> <p>Allego procedura provata</p>
20/07/2018 10:52:55	<p>Gentile Cliente, la ringraziamo per la sua preziosa segnalazione, che sarà valutata nella definizione delle prossime priorità di sviluppo del software TEXA.</p> <p>Cordiali saluti e ancora grazie per la collaborazione.</p>

At the bottom of the form are two buttons: 'Annulla' and 'Chiudi richiesta'.

Below the form is a section titled 'Precedenti Richieste' with a table:

Stato	Testo Domanda
Seleziona	Il bollettino che spiega come lasciare il quadro acceso (presente su serie 5 nuova) va linkato anche a questa...

Icon	Name	Description
	answer	It allows answering or requesting further information to the TEXA technician.

	Delete	It allows deleting the request if the answer by the TEXA technician is satisfactory.
---	--------	--

The acceptance by a TEXA technician of the notification is notified by a specific message.

78.3 Self-diagnosis SW fault notification



This function allows sending data and information on operations carried out during the diagnosis but not successful.

Proceed as follows:

1. Repeat the operation that generates the fault or problem.

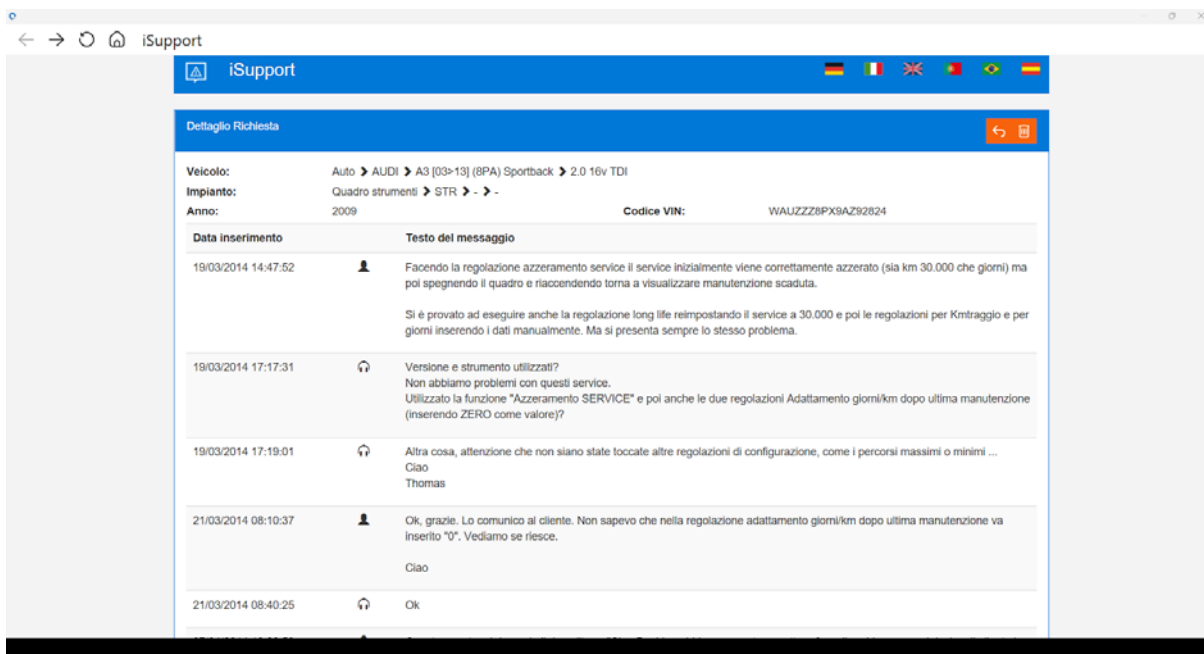
1. Press:



Icon	Name	Description
	answer	It allows answering or requesting further information to the TEXA technician.
	Delete	It allows deleting the request if the answer by the TEXA technician is satisfactory.

79 HELP / SUPPORT





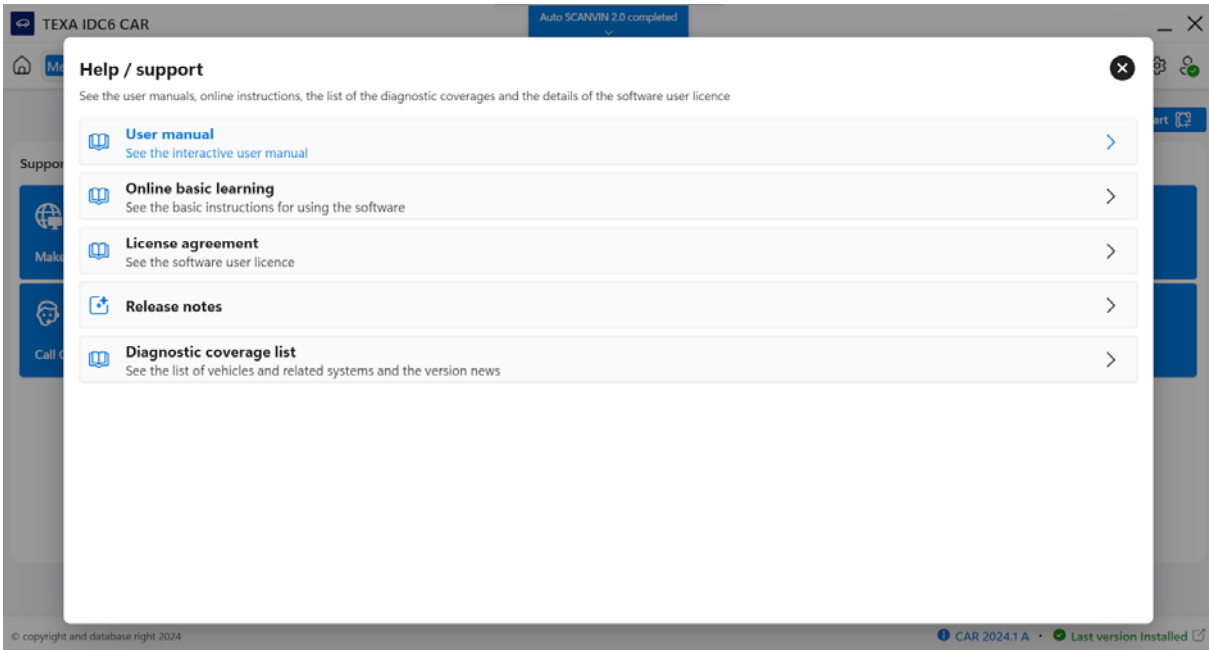

This function allows you to access the documentation related to the environment selected. Proceed as follows:

1. Press: 

The documentation screen is displayed.



Icons	Name	Description
	User manual	It allows viewing the basic instructions for using the software.
	Online basic learning	It allows viewing the basic instructions for using the software.
	User licence	It allows viewing the software user licence.
	Release notes	It allows viewing a document containing all the new features available in the installed version of the current environment.
	Diagnostic coverage list	It allows accessing the list of vehicles, systems and new features available in the installed version of the current environment.

2. Press on the desired document to display it.

79.1 User Manual

This function allows displaying the interactive user manual.

INFORMATION

The document is the same for all the environments.

Proceed as follows:

1. Press: 

The selected document appears.

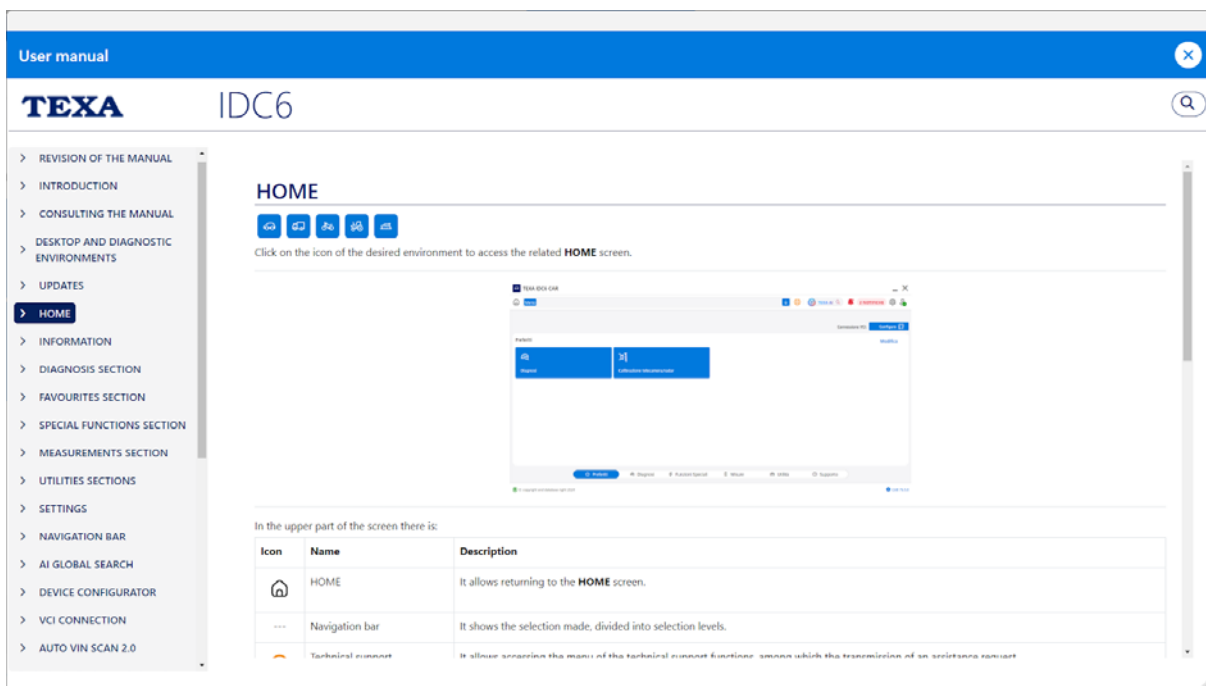

You can carry out searches in the manual using the side summary or the free search field.

79.2 Online Basic Instructions

This function allows displaying the basic instructions for using the software.

Proceed as follows:

1. Press: 

The selected document appears.

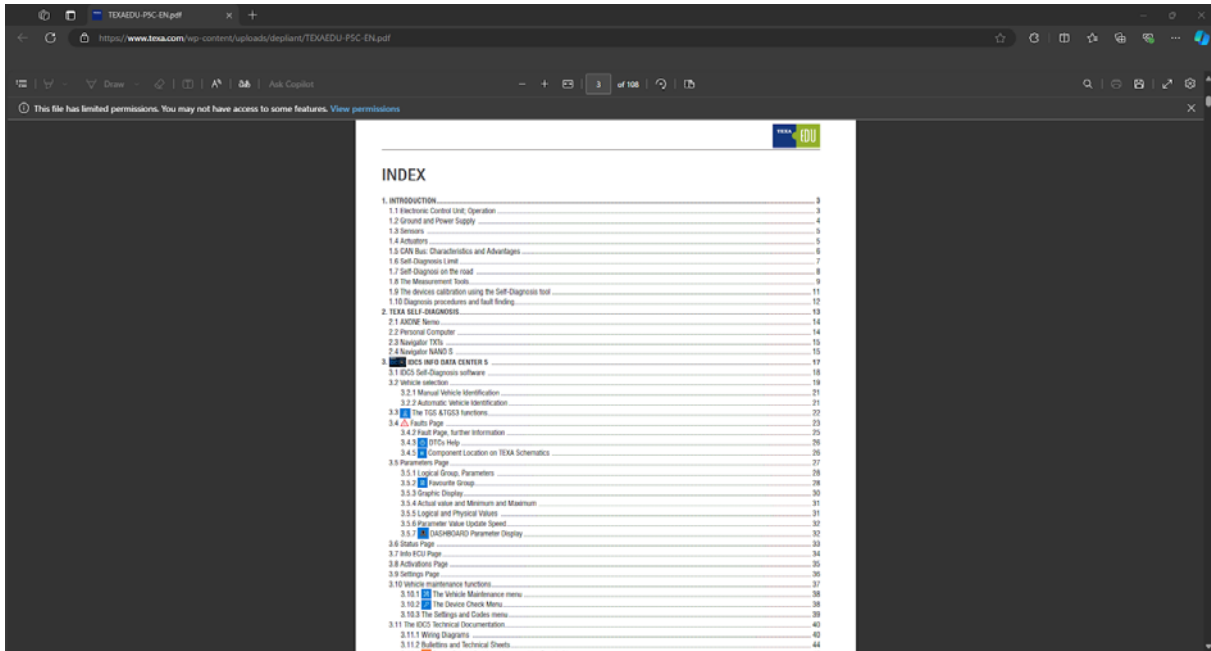

79.3 License agreement

This function allows displaying the software's user licence.

Proceed as follows:



1. Press:

The selected document appears.

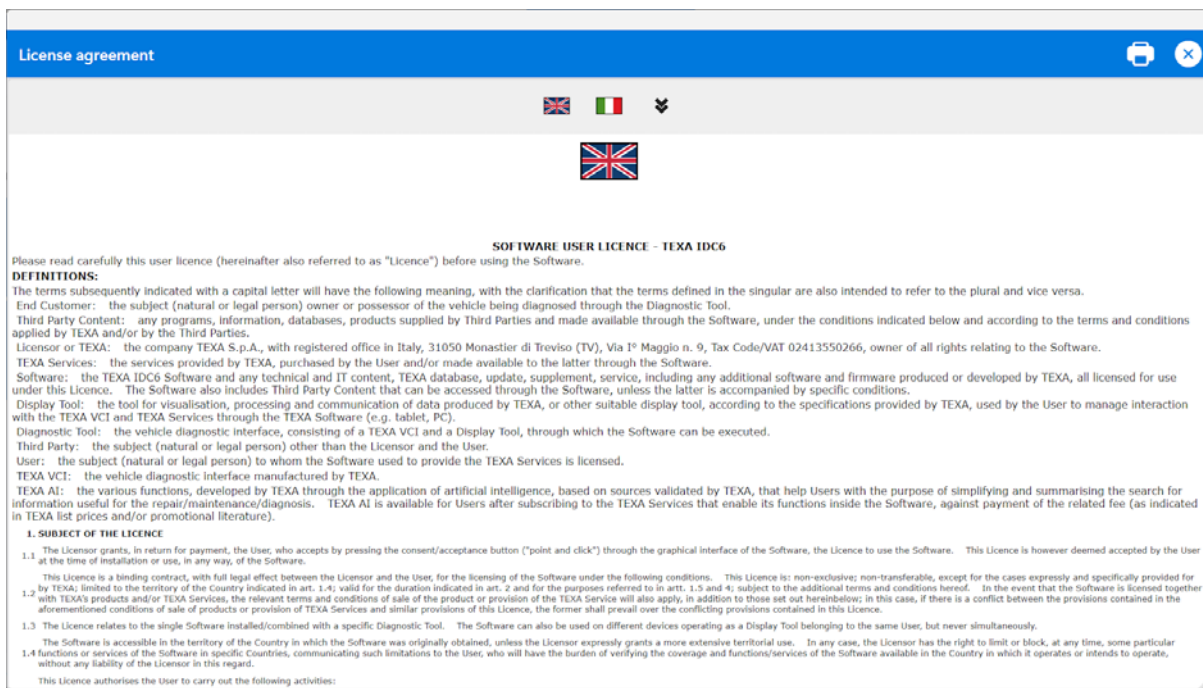

INFORMATION

You can print the document using the specific function.

79.4 Release Notes

This function allows displaying a document containing all the new features available in the installed version of the current environment.

INFORMATION

The information refers to the environment currently being used.

Proceed as follows:

1. Press: 

The selected document appears.



INFORMATION

You can print the document using the specific function.

79.5 Diagnostic Coverage List

This function allows accessing the list of vehicles, systems and new features available in the installed version of the current environment.

INFORMATION

The information refers to the environment currently being used.

Proceed as follows:

1. Press: 

The function's main screen is displayed.

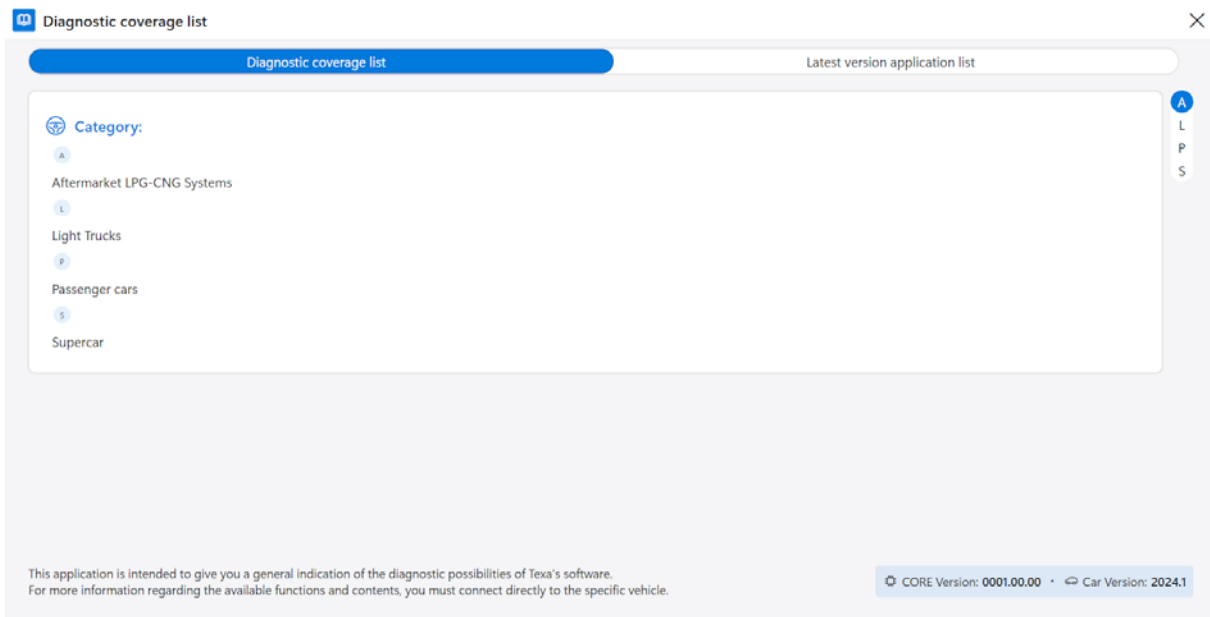

The following sections are available:

Name	Description
Diagnostic coverage list	It allows accessing the complete list of vehicles on which diagnostic operations can be carried out through the software version currently installed.
New feature list of the latest version	It allows accessing the list of new features available in the software version currently installed.

79.5.1 Diagnostic coverage list

This function allows accessing the complete list of the vehicles on which diagnostic operations can be carried out through the software version currently installed.

The function allows searching for a vehicle in a similar way as during the diagnosis preparation phase.

Proceed as follows:

1. Press: **Diagnostic coverage list**

1. Select the **Category**.

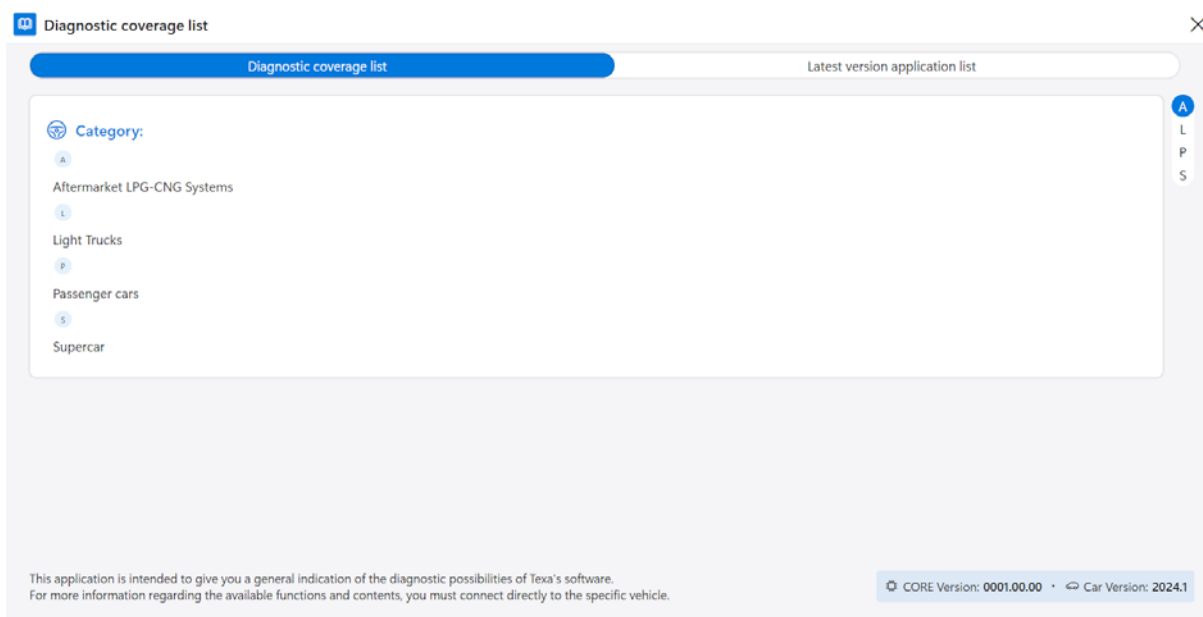

1. Select the **Make**.

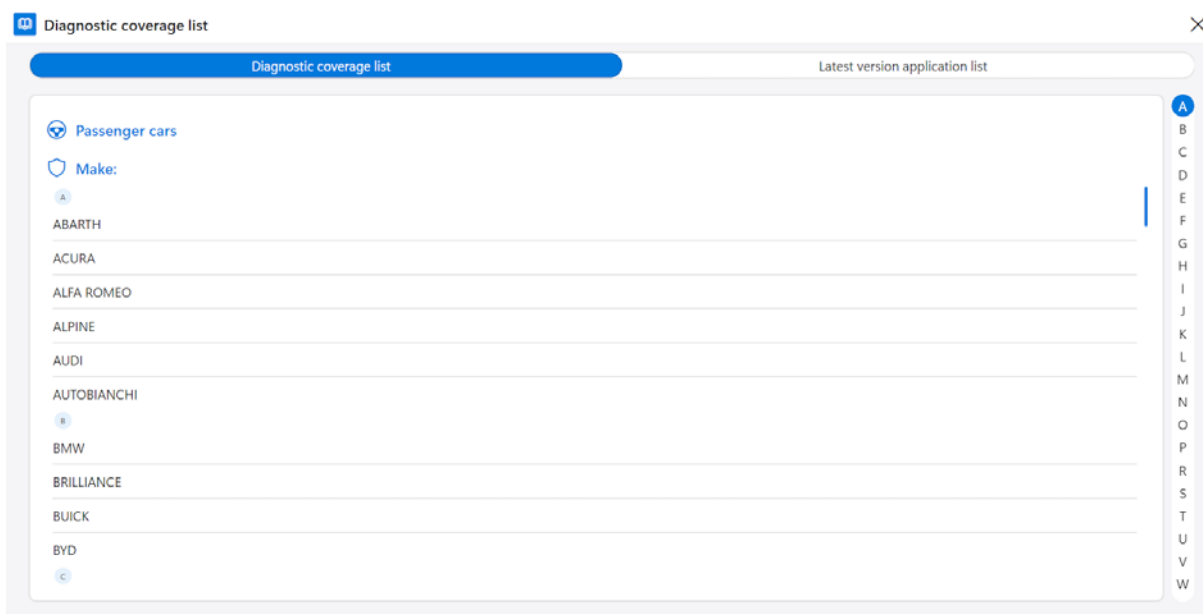

1. Select the Model.

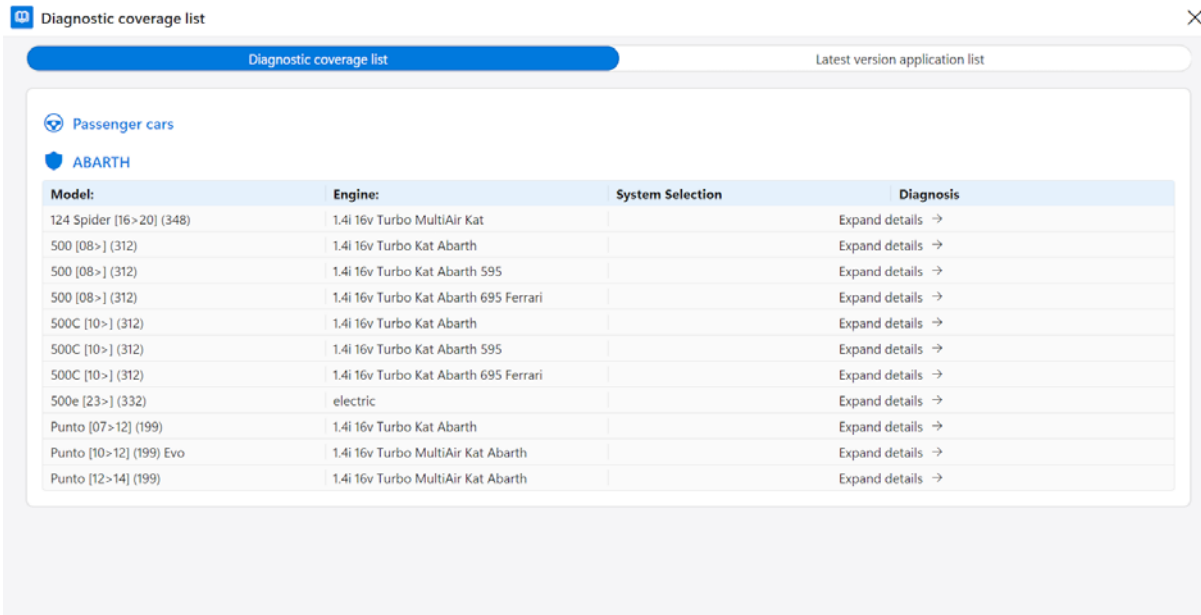

The systems that can be diagnosed and related operations available are displayed.

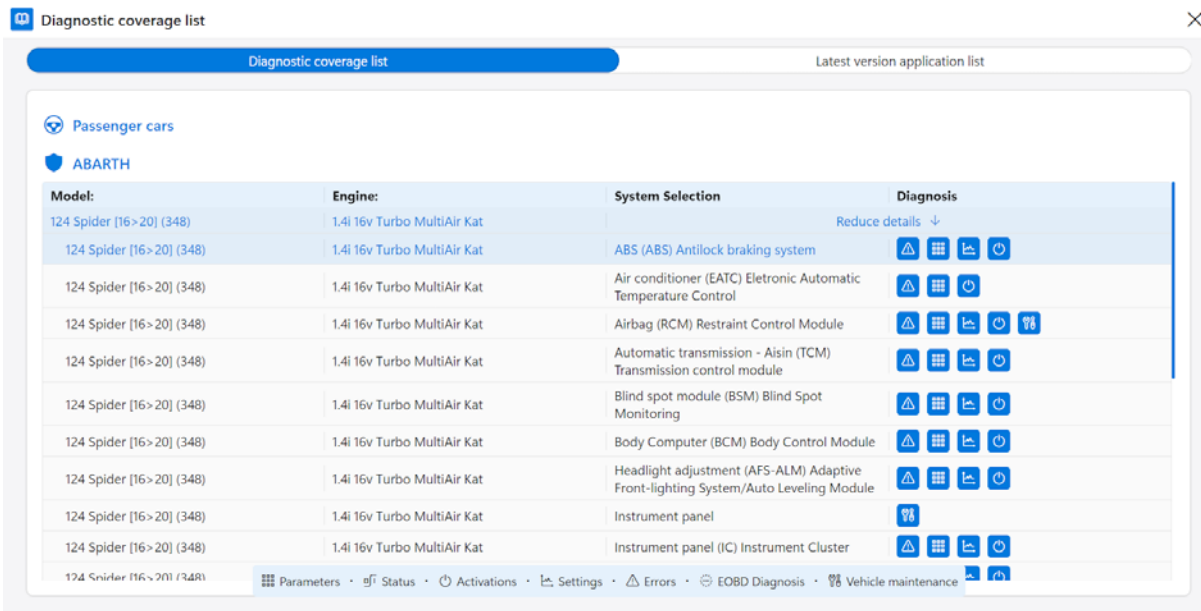

INFORMATION

By pressing on one of the icons in correspondence of the model selected, its legend can be displayed.

79.5.2 New feature list of the latest version

This function allows accessing the list of the new features available in the software version currently installed.

The function allows searching for the new features related to a vehicle in a similar way as during the diagnosis preparation phase.

Proceed as follows:

1. Press: **New feature list of the latest version**

The function's main screen is displayed.

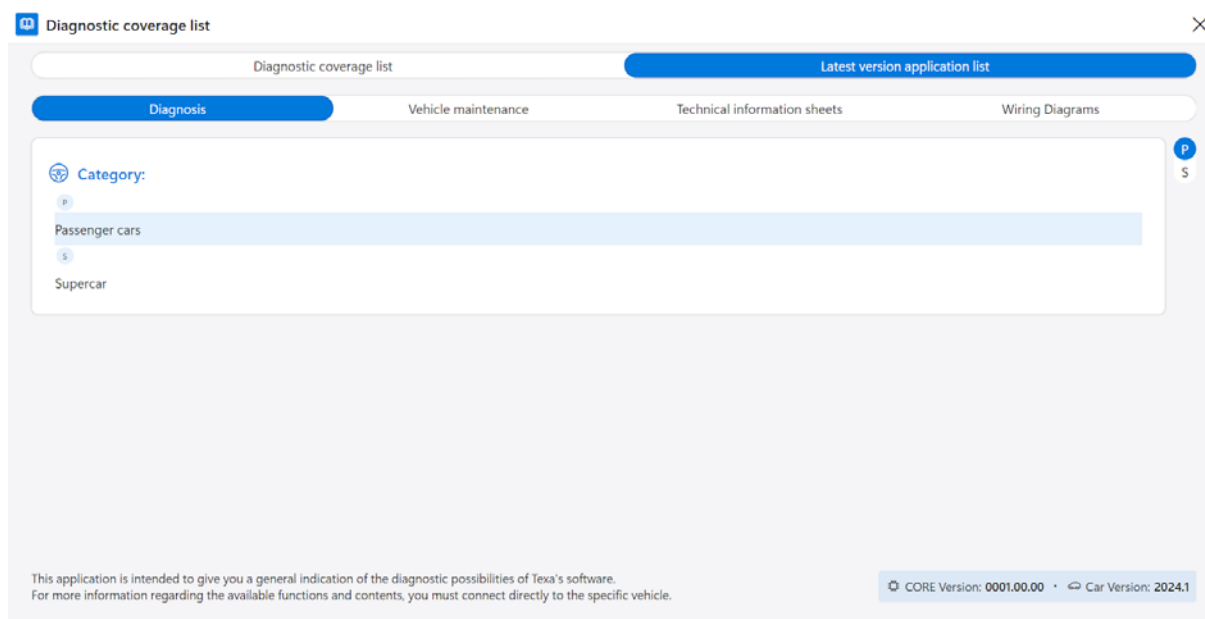

The following sections are available:

Name	Description
Diagnosis	It allows accessing the list of the new vehicles included in the software version currently installed.
Vehicle maintenance	It allows accessing the list of the new vehicle maintenances included in the software version currently installed.
Technical sheets	It allows accessing the list of the new technical sheets included in the software version currently installed.
Wiring diagrams	It allows accessing the list of the new wiring diagrams included in the software version currently installed.

2. Press on the desired section.
3. Carry out the vehicle selection.