

# AXONE NEMO PLUS



Rev.

**TEXA**

ENGLISH.....5



# SUMMARY

<b>1 REVISION OF THE MANUAL.....</b>	<b>5</b>
<b>2 INTRODUCTION.....</b>	<b>6</b>
<b>3 LEGEND OF THE SYMBOLS USED.....</b>	<b>7</b>
<b>4 SAFETY RULES.....</b>	<b>9</b>
4.1 Intended Use.....	9
4.2 Glossary.....	9
4.3 General Rules.....	10
4.4 Operator Safety.....	11
4.5 Display Unit Safety.....	12
4.6 Use in Difficult Environmental Conditions.....	13
<b>5 ENVIRONMENTAL INFORMATION.....</b>	<b>14</b>
<b>6 OPERATION OF THE RADIO DEVICES.....</b>	<b>15</b>
<b>7 REGULATORY INFORMATION .....</b>	<b>16</b>
<b>8 AXONE NEMO PLUS.....</b>	<b>22</b>
<b>9 DESCRIPTION.....</b>	<b>24</b>
<b>10 TECHNICAL FEATURES .....</b>	<b>25</b>
<b>11 POWER SUPPLY.....</b>	<b>27</b>
11.1 Power Supply from the Mains.....	28
<b>12 POWER ON/OFF.....</b>	<b>29</b>
12.1 Power on.....	29
12.2 Sleep (standby).....	29
12.3 Shutdown.....	30
12.3.1 .....	
12.4 Forced System Shutdown (Soft Reset).....	31
12.5 Hard Reset.....	31
<b>13 PRELIMINARY OPERATIONS.....</b>	<b>33</b>
13.1 MINIDOCKING USB module installation.....	33
13.2 Internal Battery Charge.....	33
13.3 First Operating System Configuration.....	33
13.4 WiFi Network Configuration.....	34
13.5 Diagnostic Software Installation.....	34

<b>14 CONNECTIVITY .....</b>	<b>36</b>
14.1 USB.....	36
14.2 Bluetooth.....	37
14.3 WiFi.....	38
<b>15 ADDITIONAL FEATURES.....</b>	<b>39</b>
15.1 Cameras and Flashlight.....	39
15.2 Touchscreen.....	39
15.3 On-Screen Keyboard.....	39
<b>16 DIAGNOSTIC SOFTWARE.....</b>	<b>40</b>
16.1 Connection with the Peripheral Diagnostic Devices.....	42
16.2 Update.....	43
<b>17 MINIDOKING USB.....</b>	<b>44</b>
17.1 Description.....	44
17.2 Technical Features.....	45
17.3 Installation.....	46
<b>18 OPTIONAL ACCESSORIES.....</b>	<b>48</b>
<b>19 BLINK CODES.....</b>	<b>49</b>
<b>20 MAINTENANCE.....</b>	<b>50</b>
<b>21 TROUBLESHOOTING.....</b>	<b>51</b>
<b>22 LEGAL NOTICES.....</b>	<b>53</b>

## 1 REVISION OF THE MANUAL

This document is the technical manual for the product: AXONE NEMO PLUS

Document Review Number: 02

Date of Issue: 25/03/2024

<b>INFORMATION</b>	<p><i>Read this manual before using the product.</i></p> <p><i>Read the documents carefully whenever the General Risk symbol is shown.</i></p>
	

## 2 INTRODUCTION

Dear Customer,

We would like to thank you for choosing a TEXA product for your workshop.

We are certain that you will get the greatest satisfaction from it and receive a great deal of help in your work.

Please read through the instructions in this manual carefully and keep it for future reference.

Reading and understanding the following manual will help you to avoid damage or personal injury caused by improper use of the product to which it refers.

TEXA S.p.A reserves the right to make any changes deemed necessary to improve the manual for any technical or marketing requirement; the company may do so at any time without prior notice.

This product is intended for use by technicians specialised in the automotive field only. Reading and understanding the information in this manual cannot replace adequate specialised training in this field.

The sole purpose of the manual is to illustrate the operation of the product sold. It is not intended to offer technical training of any kind and technicians will therefore carry out any interventions under their own responsibility and will be accountable for any damage or personal injury caused by negligence, carelessness, or inexperience, regardless of the fact that a TEXA S.p.A. tool has been used based on the information within this manual.

Any additions to this manual, useful in describing the new versions of the program and new functions associated to it, may be sent to you through our TEXA technical bulletin service.





















This manual should be considered an integral part of the product to which it refers. In the case it is resold the original buyer is therefore required to forward the manual to the new owner.





Reproduction, whole or in part, of this manual in any form whatsoever without written authorization from the producer is strictly forbidden.

The original manual was written in Italian, every other language is a translation of the original manual.

© **copyright and database rights 2022.** The material contained in this publication is protected by copyright and database rights. All rights are reserved by law and under international conventions.

### 3 LEGEND OF THE SYMBOLS USED

	Toxic material hazard		Floor level obstacle warning
	Explosive material hazard		Laser beam hazard
	Electric shock hazard		Low temperature danger - freezing
	Electromagnetic field hazard		General Risk
	Flammable material hazard		Obligation to read the instructions
	Hot surface hazard		Safety glasses required
	Corrosive substance hazard		Protective gloves required
	Risk of noise level above 80 dB(A)		Protective clothing required
	Moving Parts Risk		Respiratory protection required
	Risk of crushing hands		Disconnect mains plug from electrical outlet

	This is not a safety symbol. It indicates a hazardous situation which, if not avoided, will result in serious permanent injury or death.
	This is not a safety symbol. It indicates a hazardous situation which, if not avoided, may result in serious permanent injury or death.
	This is not a safety symbol. It indicates a hazardous situation which, if not avoided, may result in minor injury.
	This is not a safety symbol. It indicates a hazardous situation which, if not avoided, may result in material damage.

**INFORMATION**

This is not a safety symbol.  
It indicates important information.

## 4 SAFETY RULES

The technology used for the design and manufacturing control of the **AXONE NEMO PLUS** display units makes them reliable, simple and safe to use.

The personnel in charge of using the diagnostic tools are required to follow the general safety rules, use the **AXONE NEMO PLUS** display units for their intended use only, and carry out the maintenance as described in this manual.

All the safety requirements issued by the following must be assessed and applied:

- *Labor inspectorate.*
- *Trade associations.*
- *Vehicle manufacturers.*
- *Anti-pollution regulations.*

in force in the country where the product is used.

### INFORMATION

*The indications below are generally valid also for the display unit's modules (as optional or standard equipment).*

*Further and specific indications are provided when needed in the related chapters / manuals.*

### 4.1 Intended Use

Product	Intended Use
AXONE NEMO PLUS	connection and management of peripheral devices for self-diagnostics through specific software

### 4.2 Glossary

**Operator:** qualified individual responsible for using the display unit.

**Display unit:** **AXONE NEMO PLUS**

**Peripheral device:** any tool or device that the display unit can interface with.

### INFORMATION

*The definition of "operator" cannot be applied to minors or to people with reduced physical, sensory or mental capabilities or without any experience or knowledge required.*

### 4.3 General Rules



**The operator must have carefully read and fully understood all the information and instructions in the technical documents provided with the display unit. If the operator cannot read this manual, it is responsibility of the owner of the tool/employer/person in charge of the safety to illustrate the contents of this document and adequately train the operator in relation to the operating instructions and safety measures for a proper use of the tool.**

- *The operator that works on vehicles must have basic qualifications and knowledge of mechanics, automotive engineering, vehicle repairing and of the potential dangers that may arise during self-diagnosis operations.*
- *The operator must follow all the instructions provided in the technical documents.*
- *The operator must monitor the display unit during the operating phases wherever this is possible in compliance with the safety measures indicated below.*
- *The operator must periodically check the electrical connections of the display unit, making sure they are in good condition and immediately replacing any damaged cables.*
- *Contact your retailer for any non-scheduled maintenance.*
- *Do not remove or damage the labels on the display unit; do not in any case make them illegible.*
- *The display unit can be used by children aged 8 years and above and persons with reduced physical, sensory or mental capabilities, or lack of experience or necessary knowledge, as long as they are supervised or given instructions concerning safe use of the equipment and understand the hazards involved.*
- *Children must not play with the display unit.*

## 4.4 Operator Safety

### CAUTION



The display unit and portable devices that contain WAN wireless modems in general, use radio signals and it is not possible to guarantee a connection to a mobile network in all conditions.

Remember that in order to make or receive calls, the display unit or portable devices containing the WAN wireless modem must be switched on in an area within the signal's range.

Some networks do not allow emergency calls if certain network services or device functions are in use (for example, lock functions, etc.).

Some networks require a valid SIM card to be inserted in the display unit or portable device containing the WAN wireless modem.

#### Safety Measures:

- *Do not rely exclusively on wireless devices for essential communications, for example emergency calls.*
- *Check whether lock and similar functions need to be deactivated in order to make emergency calls.*

### WARNING



A display unit positioned in an airbag expansion area can be thrown towards the occupants in the vehicle causing severe damage and injuries in case of a violent impact.

#### Safety Measures:

- *Do not place the display unit in the airbag expansion zone.*

### WARNING



Some self-diagnosis operations allow you to activate/deactivate certain actuators and safety systems on the vehicle.

#### Safety Measures:

- *In order to avoid injuries and/or damage to the device or the electronic systems in the vehicle connected to the unit, do not allow unqualified personnel to use the display unit.*
- *Follow the instructions supplied by the software closely and carefully.*

### WARNING



The driver of a vehicle is responsible for driving in a responsible and safe manner.

The use of the display unit while driving can be a distraction and may be limited or banned in some areas.

### Safety Measures:

- *Always respect the laws and regulations in force with respect to the use of mobile devices.*
- *Do not input nor check written data while driving.*
- *Enter the destination information before starting to drive.*
- *Do not enter navigation information while driving.*
- *Do not carry out any operation that may distract your attention from the road.*

### 4.5 Display Unit Safety

#### NOTICE



The display unit was designed to be used in specific environmental conditions.

Using the display unit in environments with temperature and humidity values that differ from those specified may impair its efficiency.

### Safety Measures:

- *Always place the display unit in a dry area.*
- *Do not expose or use the display unit close to heat sources.*
- *Do not place the display unit on hot surfaces.*
- *Do not use corrosive chemicals, solvents or harsh detergents to clean the display unit.*

#### NOTICE



The display unit was designed to be mechanically tough and suitable for use in a workshop.

Careless use and excessive mechanical strain may impair its efficiency.

### Safety Measures:

- *Do not drop, shake or knock the display unit.*
- *Do not perform any action that may damage the display unit.*
- *Do not open or disassemble the display unit.*
- *Never force a connector into a port.*
- *Check for any blockages in the port.*
- *Make sure the connector matches the port and that it is positioned correctly.*
- *Always place the display unit on flat surfaces with the screen facing up.*
- *Do not use sharp objects or others that may damage the screen's surface.*
- *Do not rest work tools or other weights on the display unit screen.*
- *Do not use the display unit as a work surface.*

#### NOTICE



The display unit was designed to be electrically safe and to work with specific supply voltage levels.

Failure to comply with the specifications related to the power supply may impair the efficiency of the display unit. The provided power adapter can overheat while recharging the battery.

**Safety Measures:**

- *If the unit is immersed in liquid, clean and dry the power supply jack connector with a clean cloth.*
- *Do not use external batteries to supply the display unit.*
- *Only use the power adaptor provided to recharge the internal batteries, connected to the display unit in the way described in this manual.*
- *Disconnect the power adaptor in case of overheating and let it cool down between one charge and the other.*
- *Wear the most suitable personal protective equipment to avoid static electricity.*

**NOTICE**

The electromagnetic compatibility tests carried out on the tool guarantee that it can be adapted to the technologies normally used on vehicles (e.g.: engine check, ABS, airbag, etc.). Nevertheless, if malfunctions occur you should contact the vehicle's dealer.

**4.6 Use in Difficult Environmental Conditions****NOTICE**

The AXONE NEMO PLUS display units have been designed and built for use in difficult environmental conditions.

Nevertheless, use in such conditions is considered extraordinary and not comparable to normal product use. Such use can, therefore, cause the deterioration of the unit and its working life.

**Safety Measures:**

- *Do not wet or immerse the display unit in chemical substances.*
- *Should the unit accidentally get wet or be immersed in liquid, dry and clean the display unit paying particular attention to the power supply connector.*
- *Do not drop, shake or knock the display unit with accessory modules connected to it.*
- *Do not expose the display unit to outdoor weather conditions.*
- *Only use the display unit for the purposes it was designed for and in any case never in an improper manner.*
- *Avoid the display unit coming into contact with powders and dirt in general wherever possible.*

**NOTICE**

The AXONE NEMO PLUS display units were designed and built according to drop standards MIL STD 810G TRANSIT DROP TEST.

The compliance with these standards ceases if the safety conditions described in this chapter are not met.

## 5 ENVIRONMENTAL INFORMATION



Do not dispose of this product with other undifferentiated solid waste.  
For information regarding the disposal of this product please see the pamphlet supplied.

## 6 OPERATION OF THE RADIO DEVICES

### Wireless connection with Bluetooth and WiFi technology

The wireless connectivity with Bluetooth and WiFi technology supplies a standard and reliable method to exchange information between different devices, using radio waves. Other than TEXA products, even products such as cellular phones, portable devices, computers, printers, cameras, Pocket PCs, etc. use this type of technology.



The Bluetooth and WiFi interfaces look for compatible electronic devices according to the radio signal they emit and establish a connection between them. TEXA tools select and only prompt you with compatible TEXA devices. This does not exclude the presence of other sources of communication or disturbance.

THE EFFICIENCY AND THE QUALITY OF THE BLUETOOTH AND WiFi COMMUNICATIONS MAY BE INFLUENCED BY THE PRESENCE OF RADIO DISTURBANCE SOURCES. THE COMMUNICATION PROTOCOL HAS BEEN DEVELOPED TO MANAGE THESE TYPES OF ERRORS; HOWEVER, IN THESE CASES COMMUNICATION MAY BECOME DIFFICULT AND CONNECTION MAY REQUIRE SEVERAL ATTEMPTS.

SHOULD THE WIRELESS CONNECTION BE CRITICAL AND COMPROMISE A REGULAR COMMUNICATION, THE SOURCE OF THE ENVIRONMENTAL ELECTROMAGNETIC DISTURBANCE MUST BE IDENTIFIED AND ITS INTENSITY MUST BE REDUCED.

Position the tool so that the radio devices it is equipped with can work properly. In particular, do not cover it with any shielding materials or with any metallic materials in general.

## 7 REGULATORY INFORMATION

	<p>The manufacturer, TEXA S.p.A., declares that the radio equipment type <b>AXONE NEMO PLUS</b> is compliant with the following directives:</p> <ul style="list-style-type: none"><li>• <i>RED 2014/53/EU</i></li><li>• <i>RoHS 2011/65/EU and Delegated Directive 2015/863/EU</i></li></ul> <p>The complete text of the EU declaration of conformity is available at the following Internet address <a href="http://www.texa.it/download">http://www.texa.it/download</a>.</p>
	<p>The manufacturer, TEXA S.p.A., declares that the radio equipment type <b>AXONE NEMO PLUS</b> is compliant with the following regulations:</p> <ul style="list-style-type: none"><li>• <i>Radio Equipment Regulation 2017 No. 1206</i></li><li>• <i>Regulation 2012 No. 3032</i></li></ul> <p>The complete text of the UK declaration of conformity is available at the following Internet address <a href="http://www.texa.it/download">http://www.texa.it/download</a>.</p>

## Use restrictions and warnings (FCC / ISED)

### Modification statement

Changes or modifications not expressly approved by the party responsible for compliance could void the user's authority to operate the equipment.

*Les changements ou modifications non expressément approuvés par la partie responsable de la conformité peuvent annuler le droit de l'utilisateur à utiliser l'équipement.*

### Labeling information

Device model: **AXONE NEMO PLUS**

- *Contains FCC ID: PD9AX210NG*
- *Contains IC: 1000M-AX210NG*

### FCC Compliance

This device complies with part 15 of the FCC Rules. Operation is subject to the following two conditions: (1) This device may not cause harmful interference, and (2) this device must accept any interference received, including interference that may cause undesired operation.

This equipment has been tested and found to comply with the limits for a Class B digital device, pursuant to part 15 of the FCC Rules. These limits are designed to provide reasonable protection against harmful interference in a residential installation.

This equipment generates, uses and can radiate radio frequency energy and, if not installed and used in accordance with the instructions, may cause harmful interference to radio communications. However, there is no guarantee that interference will not occur in a particular installation. If this equipment does cause harmful interference to radio or television reception, which can be determined by turning the equipment off and on, the user is encouraged to try to correct the interference by one or more of the following measures:

- *Reorient or relocate the receiving antenna.*
- *Increase the separation between the equipment and receiver.*
- *Connect the equipment into an outlet on a circuit different from that to which the receiver is connected.*
- *Consult the dealer or an experienced radio/TV technician for help.*

*Cet appareil est conforme à la partie 15 des règlements de la FCC. L'utilisation est soumise aux deux conditions suivantes: (1) l'appareil ne doit pas produire de brouillage, et (2) l'appareil doit accepter tout brouillage radioélectrique subi, même si le brouillage est susceptible d'en compromettre le fonctionnement.*

*Remarque: Cet équipement a été testé et déclaré conforme aux limites d'un appareil numérique de classe B, conformément à la partie 15 des règlements de la FCC. Ces limites sont conçues pour fournir une protection raisonnable contre les interférences nuisibles dans une installation résidentielle.*

*Ce produit génère, utilise et peut émettre des ondes radio qui peuvent causer des interférences nuisibles s'il n'est pas installé et utilisé conformément aux instructions. Si néanmoins ce produit cause des interférences nuisibles à la réception de la radio ou de la télévision, ce qui peut être déterminé en éteignant et en rallumant l'appareil, l'utilisateur est encouragé à essayer de corriger l'interférence par une ou plusieurs des mesures suivantes:*

- Réorienter ou déplacer l'antenne de réception.*
- Augmenter la distance entre le produit et le récepteur.*
- Brancher l'appareil sur une prise de courant différente de celle à laquelle le récepteur est raccordé.*
- Consulter le revendeur ou un technicien radio/TV expérimenté pour obtenir de l'aide.*

## ISED compliance

This device contains license-exempt transmitter(s)/receiver(s) that comply with Innovation, Science and Economic Development Canada's license exempt RSS(s). Operation is subject to the following two conditions: (1) This device may not cause interference. (2) This device must accept any interference, including interference that may cause undesired operation of the device.

This radio transmitter has been approved by Innovation, Science and Economic Development Canada to operate with the antenna types listed below, with the maximum permissible gain indicated. Antenna types not included in this list that have a gain greater than the maximum gain indicated for any type listed are strictly prohibited for use with this device.

*L'émetteur/recepteur exempt de licence contenu dans le present appareil est conforme aux CNR d'Innovation, Sciences et Développement économique Canada applicables aux appareils radio exempts de licence. L'exploitation est autorisée aux deux conditions suivantes : (1) L'appareil ne doit pas produire de brouillage; (2) L'appareil doit accepter tout brouillage radioélectrique subi, même si le brouillage est susceptible d'en compromettre le fonctionnement.*

*Le présent émetteur radio a été approuvé par Innovation, Sciences et Développement économique Canada pour fonctionner avec les types d'antenne énumérés ci dessous et ayant un gain admissible maximal. Les types d'antenne non inclus dans cette liste, et dont le gain est supérieur au gain maximal indiqué pour tout type figurant sur la liste, sont strictement interdits pour l'exploitation de l'émetteur.*

ICES-003 Class B Notice -Avis NMB-003 Classe B: This Class B digital device complies with Canadian ICES-003

*Cet appareil numérique classe B est conforme à la norme Canadienne NMB-003. CAN ICES-3(B) / NMB-3(B)*

### **RF Radiation Exposure statement**

This product complies with FCC and ISED radiation exposure limits set forth for an uncontrolled environment. The antenna should be installed and operated with minimum distance of 20 cm between the radiator and your body.

This device complies with Health Canada's Safety Code. The installer of this device should ensure that RF radiation is not emitted in excess of the Health Canada's requirement.

*Cet appareil est conforme aux limites d'exposition aux rayonnements de l'ISED pour un environnement non contrôlé. L'antenne doit être installée de façon à garder une distance minimale de 20 centimètres entre la source de rayonnements et votre corps.*

*Cet appareil est conforme avec Santé Canada Code de sécurité 6. Le programme d'installation de cet appareil doit s'assurer que les rayonnements RF n'est pas émis au-delà de l'exigence de Santé Canada.*

## Certificação ANATEL

“Este produto está homologado pela ANATEL, de acordo com os procedimentos regulamentados pela Resolução 715/2019, e atende aos requisitos técnicos aplicados”. Para maiores informações, consulte o site da ANATEL [www.anatel.gov.br](http://www.anatel.gov.br)



06711-24-10401

*Este equipamento não tem direito à proteção contra interferência prejudicial e não pode causar interferência em sistemas devidamente autorizados.*

## 8 AXONE NEMO PLUS

**AXONE NEMO PLUS** is the TEXA display unit designed and created for easy use during diagnostic activities, in any working condition.



The device's body in magnesium guarantees: robustness, rigidity, lightness and excellent heat dissipation.

The device has a rear camera complete with: autofocus, flash and flashlight mode, useful in order to create detailed customer reports and send images of technical details to the assistance department.

A practical handle (optional) can be mounted on the device, useful for transportation, as a support base or can be hooked to the steering wheel.

### INFORMATION

*For further information see the Optional accessories chapter.*

**AXONE NEMO PLUS** is equipped with:

- *digital accelerometer*

This equipment allows taking full advantage of the functions of the software installed in the display unit.

**AXONE NEMO PLUS** mounts the following modules:

- **BLUETOOTH:** *it allows the display unit to connect to a large range of diagnostic and measuring tools and devices and to work freely around the vehicle or comfortably sitting inside it.*
- **WiFi:** *it allows the display unit to connect to the Internet and download updates by connecting to a router / access point or to your smartphone.*

**AXONE NEMO PLUS** can also be used in combination with the different models of **additional modules** designed to further increase its practical use.

### INFORMATION

*For further information, contact your retailer.*



## 9 DESCRIPTION

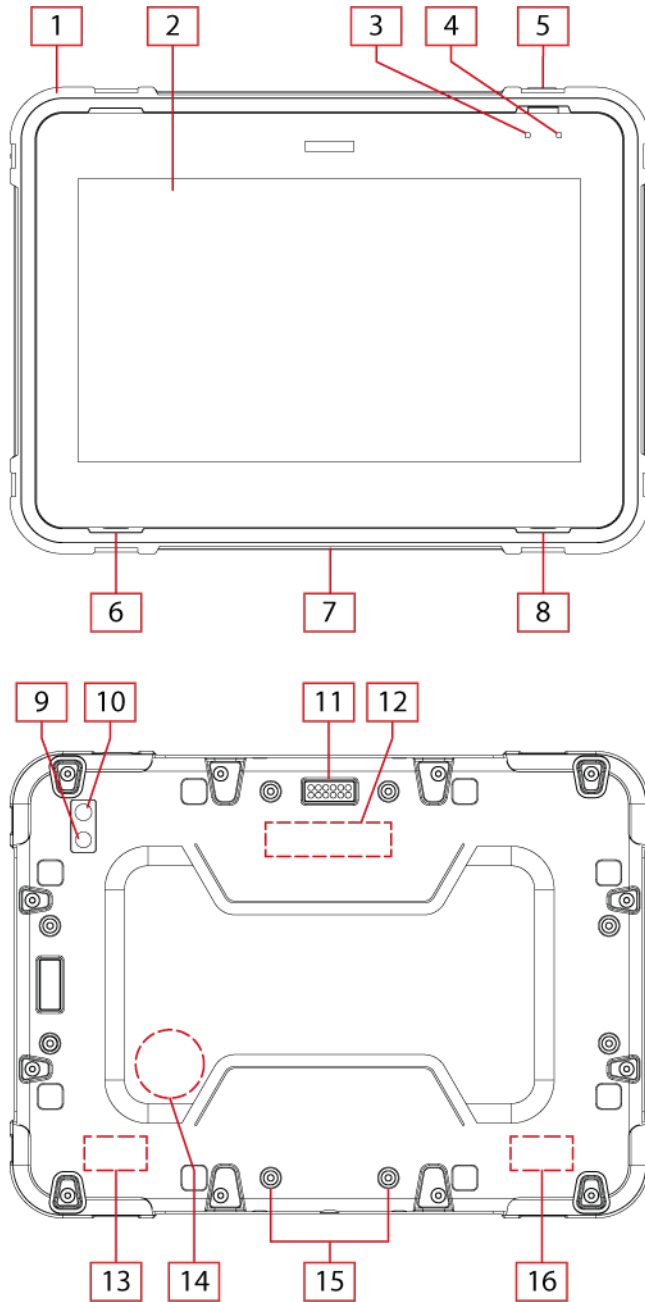

1. Protective case
2. Touchscreen
3. Red LED
4. Green LED
5. POWER button
6. Speaker
7. Power supply connector
8. Speaker
9. Camera
10. Flash / flashlight
11. Connector for expansion modules
12. Magnet
13. Dual-band WiFi / BT antenna
14. Sensors
15. Threaded inserts
16. Dual-band WiFi / BT antenna

# 10 TECHNICAL FEATURES

<b>Manufacturer:</b>	TEXA S.p.A.
<b>Model:</b>	AXONE NEMO PLUS
<b>Processor:</b>	Intel N100
<b>RAM memory:</b>	16 GB DDR5
<b>Hard Disk:</b>	250 GB SSD PCIe
<b>Bios:</b>	64 Mbit Flash ROM, AMI BIOS
<b>Operating system:</b>	Windows™ 11 IoT Enterprise Trusted Platform Mobile 2.0
<b>Video peripheral devices (built-in):</b>	High-contrast ultra-wide viewing angle 11.6" QXGA display; 1920x1080 pixel; 216 ppi, high sensitivity touch controller
<b>Audio processor:</b>	Realtek ALC892-CG
<b>Audio peripheral devices (built-in):</b>	2 speaker 1 MEMS digital microphone
<b>Wireless peripheral devices (built-in):</b>	<ul style="list-style-type: none"> <li>• <i>WiFi: 6E (802.11ax)</i></li> <li>• <i>Bluetooth: 5.3</i></li> </ul>
<b>Sensors:</b>	<ul style="list-style-type: none"> <li>• <i>± 8 g 3-axis digital accelerometer</i></li> </ul>
<b>External I/O peripheral devices:</b>	1 proprietary connector for hub with 4 Type-A USB ports with total output current of 1 A
<b>Cameras:</b>	2 Mpixel, LED flash
<b>LED:</b>	1 green LED (system status) 1 red LED ( charging / power supply status)
<b>Internal battery:</b>	Rechargeable Li-ion 7,2 Vdc; 6990 mAh; 50,3 Wh
<b>Display unit internal battery recharging temperature</b>	0 ÷ 45 °C
<b>External power supply:</b>	<p>From external power adapter</p> <ul style="list-style-type: none"> <li>• <i>Model: TRH070A190</i></li> <li>• <i>Input: 100-240 Vac; 1,5 A; 47-63 Hz</i></li> <li>• <i>Output: 19 V - 3,7 A</i></li> <li>• <i>Socket: IEC 60320-C14</i></li> <li>• <i>Cable: H05 VV-F</i></li> </ul>
<b>Autonomy:</b>	approximately 5 h
<b>Operating temperature:</b>	0 ÷ 40 °C
<b>Storage temperature:</b>	- 20 ÷ 50 °C
<b>Operating moisture:</b>	10 ÷ 80 % * (* <i>without condensation</i> )
<b>Body:</b>	Magnesium with rubber inserts

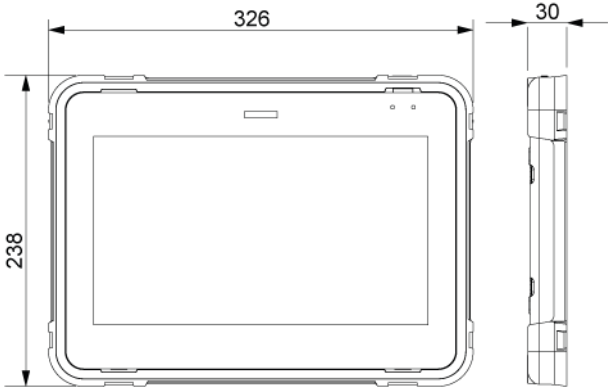
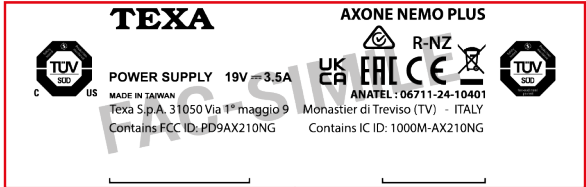
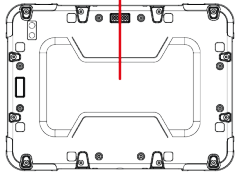
<p><b>Dimensions [mm]:</b></p>	
<p><b>Weight:</b></p>	<p>1850 g</p>
<p><b>Directives:</b></p>	<p>RED 2014/53/EU RoHS 2011/65/EU and Delegated Directive 2015/863/EU</p>
<p><b>Regulations:</b></p>	<p>Radio Equipment Regulation 2017 No. 1206 Regulation 2012 No. 3032</p>
<p><b>Electrical Safety:</b></p>	<p>EN 62368-1 MIL-STD-810G TRANSIT DROP TEST</p>
<p><b>Electromagnetic Compatibility:</b></p>	<p>EN 301 489-1 EN 301 489-17 EN 301 893 EN 300 328 EN 62479</p>
<p><b>Data plate:</b></p>	 

## 11 POWER SUPPLY

The display unit is powered by an internal rechargeable battery that allows it to be used without a mains power supply.

The autonomy supplied by the battery allows you to use the display unit for the duration of a normal working day.

The internal battery can be charged:

- *from the mains using the supplied power adapter.*

### INFORMATION

*The display unit cannot be recharged / powered through the USB ports on the MINIDOCKING USB module.*

Generally, the display unit can be used even during the battery recharging phase.

Normally, a **complete recharge** takes **about 4 hours** when connected to the mains without interruption.

### NOTICE

**Charge the internal battery completely when switching on the display unit for the first time.**

**Use the provided power adapter only.**

**Keep the display unit powered through the mains throughout the entire duration of the software update.**

**Always charge the display unit after use.**

## 11.1 Power Supply from the Mains

The display unit can be powered directly from the mains.



1. *Display unit*
2. *Power adapter*
3. *Power cable*

Proceed as follows:

1. *Connect the power adapter to the display unit.*
2. *Connect the power supply cable to the power adaptor.*
3. *Connect the power supply cable to a mains socket.*

## 12 POWER ON/OFF

The **POWER** button allows sending various commands to the display unit.

In particular:

- *ignition*
- *sleep (standby)*
- *forced system shutdown (soft reset)*
- *hard reset*

The duration of the key press determines the type of command sent.

Each type of command corresponds to specific signalling via LEDs.

### INFORMATION

*The display unit shutdown is commanded by the software through the specific functions of the operating system.*

### 12.1 Power on

The procedure for switching on the display unit is described below.

Proceed as follows:

1. *Press and hold the **POWER** button until the green LED lights up.*
2. *Release the button.*
3. *Wait for the operating system to start and for the **DESKTOP** screen to appear.*

The green LED remains on.

The display unit is now ready for use.

### INFORMATION

*If the red LED flashes while you are trying to turn on the unit, it indicates that the battery is low.*

In this case, recharge the display unit and perform the switching on procedure again.

### INFORMATION

*If you have chosen to install the diagnostic software, when the display unit is switched on, this application is launched automatically.*

*The operating system's application bar remains visible in both cases.*

*For further information see the software's Operating Manual.*

### 12.2 Sleep (standby)

The display unit's energy consumption is optimised by the screen switching off automatically when not in use and by the possibility of setting the unit to sleep (standby).

The display unit screen switches off automatically when the unit is not in use and not communicating with peripheral devices.

To turn the screen on again, touch the touchscreen.

After the screen has been turned off, the display unit will automatically go to sleep (standby) if not used for a prolonged period of time.

While the display unit is in this status, the green LED blinks slowly.

To get the display unit out of the sleep (standby) status, press the **POWER** button until the green LED lights up.

The display unit can be put to sleep (standby) manually.

Proceed as follows:

1. Press and hold the **POWER** button until the display turns off.
2. Release the button.

The green LED starts blinking slowly.

As an alternative, the display unit can be put to sleep (standby) using the specific functions of the operating system.

Proceed as follows:

1. Press on the operating system's **START** icon.
2. Open the shutdown menu.
3. Select the **Sleep** option.

To get the display unit out of the sleep (standby) status, press the **POWER** button until the green LED lights up.

## INFORMATION

*If you have chosen to install the diagnostic software, when the display unit is switched on, this application is launched automatically.*

*For further information see the software's Operating Manual.*

### 12.3 Shutdown

To turn off the display unit, use the specific shutdown menu supplied by the operating system.

Proceed as follows:

1. Press on the operating system's **START** icon.
2. Open the shutdown menu.
3. Select the **Shut down** option.

## INFORMATION

*If you have chosen to install the diagnostic software, when the display unit is switched on, this application is launched automatically.*

*For further information see the software's Operating Manual.*

## 12.4 Forced System Shutdown (Soft Reset)

If needed, you can force the display unit's shutdown.

### NOTICE

Using this procedure may cause the loss of data that has not been stored.

Proceed as follows:

1. Press and hold the **POWER** button for approximately 6 seconds.  
The display will turn off.
2. Release the button when the LEDs blink quickly and simultaneously.  
The display unit is now off.

### INFORMATION

*After a forced shutdown, the display unit must be restarted manually.*

## 12.5 Hard Reset

In rare cases, the forced system shutdown procedure may have no effect, and the display unit may get stuck in a status that does not allow it to respond to commands.

In such cases, the hard reset procedure must be used.

### NOTICE

The hard reset procedure is made up of two parts, both of which are essential to its successful completion: shutdown and manual restart.

Another condition required for the procedure to be successful is that the display unit must be disconnected from the power supply before the procedure starts and remain disconnected until the restart is completed.

Using this procedure, any unsaved data will be lost.

Proceed as follows:

1. Disconnect the display unit from the power supply.
2. Press and hold the **POWER** button for at least 12 seconds.  
After 6 seconds, the LEDs will blink quickly and simultaneously.
3. Release the button when the LEDs blink slowly and alternately.
4. Wait for the LEDs to turn off.
5. Press the **POWER** button.  
The LEDs will flash slowly and alternately.
6. Wait for the display unit to restart.

### INFORMATION

*The restart requires approximately 2 minutes.*

7. Now the display unit can be reconnected to the power supply.

## 13 PRELIMINARY OPERATIONS

In the following the preliminary operations necessary to make the display unit completely operational are described.

The operations are divided into the following phases:

1. **MINIDOCKING USB** module installation.
2. Internal battery charge.
3. First operating system configuration.
4. Connection to the **Wi-Fi** network.
5. Diagnostic software installation (optional).

### INFORMATION

*The device is provided with the Wi-Fi and Bluetooth modules already activated.*

### 13.1 MINIDOCKING USB module installation

The installation of the **MINIDOCKING USB** module allows equipping the display unit with a USB hub to which you can connect specific peripheral devices and mass storage units.

Its installation allows connecting the supplied USB flash drive.

*For further information see the MINIDOCKING USB module chapter.*

### 13.2 Internal Battery Charge

The display unit is powered by an internal battery that must be recharged completely before switching on the device the first time.

### INFORMATION

*Charge the internal battery completely when switching on the display unit for the first time.*

Proceed as follows:

1. Charge the device connecting it to the mains using the supplied power adaptor.
2. Wait for the red LED to turn off.

Normally, a **complete recharge** takes **about 4 hours** when connected to the mains without interruption.

*For further information see the Power supply chapter.*

### 13.3 First Operating System Configuration

The display unit is delivered with the operating system preinstalled and ready for the first configuration.

### INFORMATION

*Keep the device powered throughout the entire duration of this phase.*

*During the procedure the system may be restarted one or more times.*

Proceed as follows:

1. Hold down the **POWER** button until the **green LED** lights up.

2. *Accept the terms of the EULA - End-User License Agreement.*
3. *The system may restart a few times: wait for the operations to complete without turning off the display unit.*

## INFORMATION

*The first operating system configuration is carried out as established by the operating system's manufacturer.*

*The procedure described is simply a guideline.*

*For further information see the documentation provided by the operating system's manufacturer.*

At the end of the configuration the display unit's serial number is set as the display unit's name.

Once this phase is complete, the first time the display unit is turned on, an interface through which the **EOBD Scan Tool** function can be started appears.

### 13.4 WiFi Network Configuration

In order to take advantage of the display unit's potentialities, you must connect it to the workshop's **Wi-Fi** network.

Proceed as follows:

1. Make sure the workshop's **Wi-Fi** router / access point is turned on.
2. Turn on the display unit.
3. In the application bar notification area, select the network icon 
4. Select the network you wish to connect the display unit to.
5. Press Connect
6. Enter the network's password (if required).
7. Follow the additional instructions if provided by the operating system.



**For further information see the documentation provided by the operating system's manufacturer.**

### 13.5 Diagnostic Software Installation

At the end of the first configuration, you may proceed with the installation of the diagnostic software if you wish to.

The software purchased is in the supplied **USB** flash drive.

## INFORMATION

*The installation of the software is optional: if this phase is not carried out, this will not compromise the display unit's operation.*

Proceed as follows:

1. *Connect the USB flash drive to one of the ports on the **MINIDOCKING USB** module.*
2. *Access the contents of the **USB** flash drive through the system functions.*
3. *Identify the setup of the diagnostic environment purchased.*
4. *Launch the installation by pressing on the **setup.exe** file.*

5. *Follow the instructions indicated in the software's **Setup Manual**.*

The setup of the diagnostic environment and the updated versions can be downloaded through the **Download Manager** application.



**For further information see the software's Operating Manual.**

## 14 CONNECTIVITY

The display unit has several communication modes thanks to specific inbuilt modules. Each type of communication is dedicated to a specific use:

<b>USB</b>	Communication dedicated to connecting with peripheral devices. *
<b>BLUETOOTH</b>	Communication dedicated to connecting with peripheral devices.
<b>WiFi</b>	Communication dedicated to connecting to the Internet through a smartphone, a router or an access point.

(\*) Via **MINIDOCKING USB** module.

### 14.1 USB

The supplied **MINIDOCKING USB module** allows connecting peripheral devices to the display unit directly using a cable, such as:

- *mouse*
- *keypad*
- *USB flash drives*
- *diagnostic tools*

#### INFORMATION

*The current supplied through the MINIDOCKING USB module is limited and may not be enough to power some peripheral devices.*

*For further information see the MINIDOCKING USB module chapter.*

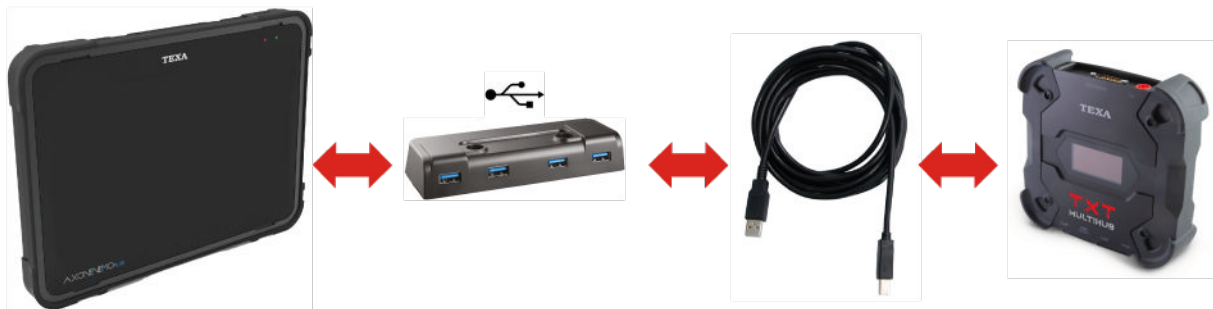

The configuration of the communication is carried out through specific software functions.



**For further information see the software's Operating Manual.**

## 14.2 Bluetooth

The **Bluetooth** module built into the display unit allows it to connect to various **peripheral devices** in the workshop.

### NOTICE

**Do not connect external Bluetooth adapters to the display unit.**



The **Bluetooth** module also allows connecting to special **wireless headphones** equipped with a microphone.

The headphones are essential for the optimal use of some **remote assistance** functions available in the software.

The configuration of the communication is carried out through specific software functions.



**For further information see the software's Operating Manual.**

### 14.3 WiFi

The **Wi-Fi** module built into the display unit allows accessing the Internet through an access point and communicating with **Wi-Fi** devices in the workshop.



The Internet connection allows you to use particular software functions that require connecting to the WEB.

Thanks to the **Wi-Fi** module it is possible to connect the display unit to a **smartphone**. This way, it is possible to exploit the features of the **smartphone** to allow the display unit to connect to the Internet.



#### INFORMATION

*The features described are only supported by some smartphones.*

*For further information, contact your retailer.*



**For further information see the software's Operating Manual.**

## 15 ADDITIONAL FEATURES

### 15.1 Cameras and Flashlight

The display unit has a front camera, a rear camera and a flash / flashlight.

The cameras are useful, for example, for photographing components that must be replaced and for which the spare part must be ordered.

The camera application and the storage of images in appropriate directories are managed through the software.

The rear camera's flash can also be used as a flashlight to light up the area you are working on.

The settings related to the cameras and flash / flashlight are managed through the functions made available by the operating system.

#### INFORMATION

*If you have chosen to install the diagnostic software, you can manage these peripheral devices through specific functions of this software.*

*For further information see the software's Operating Manual.*

### 15.2 Touchscreen

The touchscreen allows using the functions made available by the operating system and, if installed, by the diagnostic software without having to use a mouse and keyboard.

#### NOTICE

**Do not use sharp objects or others that may damage the screen's surface.**

### 15.3 On-Screen Keyboard

Using the operating system's application bar you can make the keypad appear on-screen.

The on-screen keyboard can be used to enter the data if you do not have a physical keyboard available to connect to the **MINIDOCKING USB** module.

Proceed as follows:

1. *Press on the specific icon in the operating system's toolbar.*

## 16 DIAGNOSTIC SOFTWARE

The supplied diagnostic software must be used by qualified personnel.

TEXA S.p.A. offers its customers professional training courses.

In these training courses the technicians are followed step by step by specialised personnel to give them as much familiarity as possible with the use of the tools and the software. This way the technicians will learn how to make the best use of TEXA S.p.A. products.

For further information regarding the training courses offered by TEXA S.p.A. visit the website [www.texa.it](http://www.texa.it).

The software offers functions that allow you, for example, to:

- *perform self-diagnosis tests,*
- *carry out emissions' analyses,*
- *carry out tests on the ignition and charging systems,*
- *view road test recordings.*

Furthermore, the software supplies useful technical sheets and guided procedures to help you carry out particular operations (ex.: resetting the warning lights).

All the configuration operations for the display unit are performed via the software.

The software contains specific functions dedicated to its use in the display unit.

The selections and the activation of various software functions are carried out using the touch screen.

### CAUTION

**TEXA S.p.A. is not liable for the risk of losing the user's data, leaving to the user the responsibility for the protection of the data and/or information managed by the Software and by the Operating System by copying them.**

**In no case will TEXA S.p.A. be liable for damage of any kind (including, as an example, damages due to losses or lost profits, business interruption, loss of data and/or information or other economic losses) derived from the use or the inability to use the Software and/or Operating System.**

### INFORMATION

*It is important that the display unit is connected to the Internet: in this case, the diagnostic software will automatically check that the correct version is installed and being used, without interfering with the normal use of the unit itself.*

*If 15 consecutive days have passed without any connection to the Internet, the display unit must necessarily be connected to the Internet to check that the correct software is in use, otherwise it will be locked and not usable.*

*Simply connect the display unit to the Internet again to complete the check automatically.*

*The diagnostic software will warn the customer 24 hours before the end of the 15-day period, inviting them to connect the display unit.*



**For further information regarding the installation of the software and its use, see the Setup Manual and Operating Manual.**

## 16.1 Connection with the Peripheral Diagnostic Devices

In order to carry out the tests, you must install the provided diagnostic software and then use the specific software functions to perform the guided communication configuration procedure.

You can connect the desired peripheral device to the display unit the following ways:

- *via Bluetooth;*
- *via USB (using the **MINIDOCKING USB** module);*

### INFORMATION

*The serial number to use in order to configure the Bluetooth communication is indicated on the label on the peripheral device.*

*The current supplied by the display unit through the MINIDOCKING USB module ports allows powering only certain types of peripheral devices.*

Proceed as follows:

1. *Power the peripheral device you intend to configure.*
2. *Start the diagnostic software.*
3. *Start the specific software function for the configuration of the communication.*
4. *Follow the procedure for the configuration of the communication between the display unit and the peripheral device.*

### INFORMATION

*To change the communication mode between the display unit and the peripheral device, you must carry out the configuration procedure again.*

The data collected by the peripheral devices is viewed on the display unit via the software.

### NOTICE

*Power, connect and switch on the peripheral device before launching applications that must interface with it.*

*Otherwise, communication errors may occur.*



**For further information, see the software's Operating Manual and the peripheral device's Technical Manual.**

## 16.2 Update

The update of the diagnostic software can be performed the following ways:

- **via WiFi**, *through an appropriate router / access point or a smartphone*,
- **via an external DVD player\*** *connected to the display unit through the USB 3.0 module*
- **via USB flash drive** *connected to the display unit through the MINIDOCKING USB module.*

(\*) *Not supplied*

The connection between the display unit and the router / access point / smartphone must be configured according to the instructions in the manual of the device used for Internet access.

### **NOTICE**

**Keep the display unit powered by the mains while the update is being downloaded and installed.**



**For further information see the software's Operating Manual.**

## 17 MINIDOKING USB

The **MINIDOCKING USB** is a practical accessory supplied with the display unit.



The module is equipped with:

- 4 USB 3.0 ports
- Magnets for the connection to the display unit without having to be fastened
- Screws for fastening it to the display unit

Using the module allows you to:

- connect USB devices,
- use an external DVD player / USB flash drive to update the software if not covered by a signal,
- better readability of the display unit screen when placed on a flat surface.

### INFORMATION

The maximum total current that can be supplied through the module's USB ports is 1.2 A.

### 17.1 Description

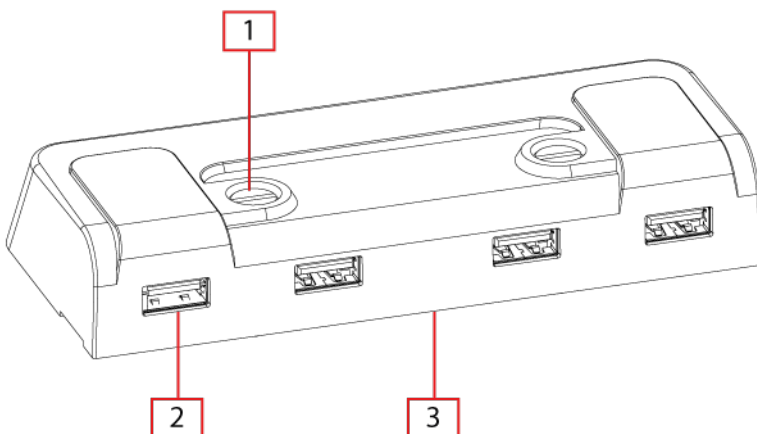

1. Fixing screws (x2)
2. USB 3.0 socket (x4)
3. Proprietary connector (lower part)

## 17.2 Technical Features

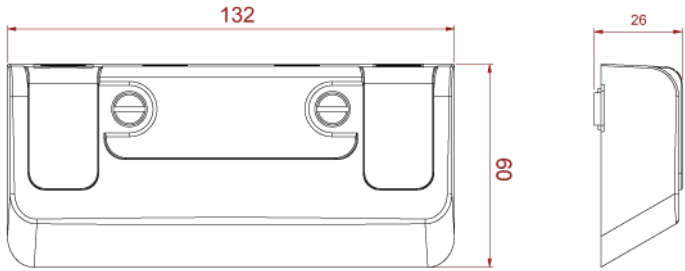
<b>Manufacturer:</b>	TEXA S.p.A.
<b>Model:</b>	MINIDOKING USB
<b>Communication connector:</b>	proprietary connector
<b>Connectors for peripheral devices:</b>	4 USB 3.0
<b>Maximum current suppliable:</b>	<ul style="list-style-type: none"> <li>• <i>per port: 5 Vdc; 900 mAdc max</i></li> <li>• <i>overall: 1,2 A</i></li> </ul>
<b>Operating temperature:</b>	0 ÷ 40 °C
<b>Storage temperature:</b>	- 20 ÷ 50 °C
<b>Operating moisture:</b>	10 ÷ 80 % * (* <i>without condensation</i> )
<b>Dimensions:</b>	 <p>The drawing shows two views of the device. The front view is a rectangular unit with a width of 132 mm and a height of 69 mm. It features two circular ports on the front face. The side view shows a depth of 26 mm. The device has a slightly raised front edge and a recessed back edge.</p>
<b>Weight:</b>	95 g

### 17.3 Installation

The module can be connected to the display unit in two ways:

<b>Only through magnetic contact</b>	It allows you to connect / disconnect the module quickly, without having to remove the peripheral devices connected to it.
<b>Magnetic contact and fixing screws</b>	It allows you to fix the module to the display unit firmly.

In both cases the USB 3.0 module's ports work perfectly.

#### **NOTICE**

The magnets used are sized in order to guarantee the module's connection to the display unit and they may not be sufficient to hold the weight of other peripheral devices connected to the module or to the display unit.

Do not lift and carry the display unit using the magnet as a handle.

The module can be installed on any of the specific connectors located on the back side of the display unit, based on your needs.

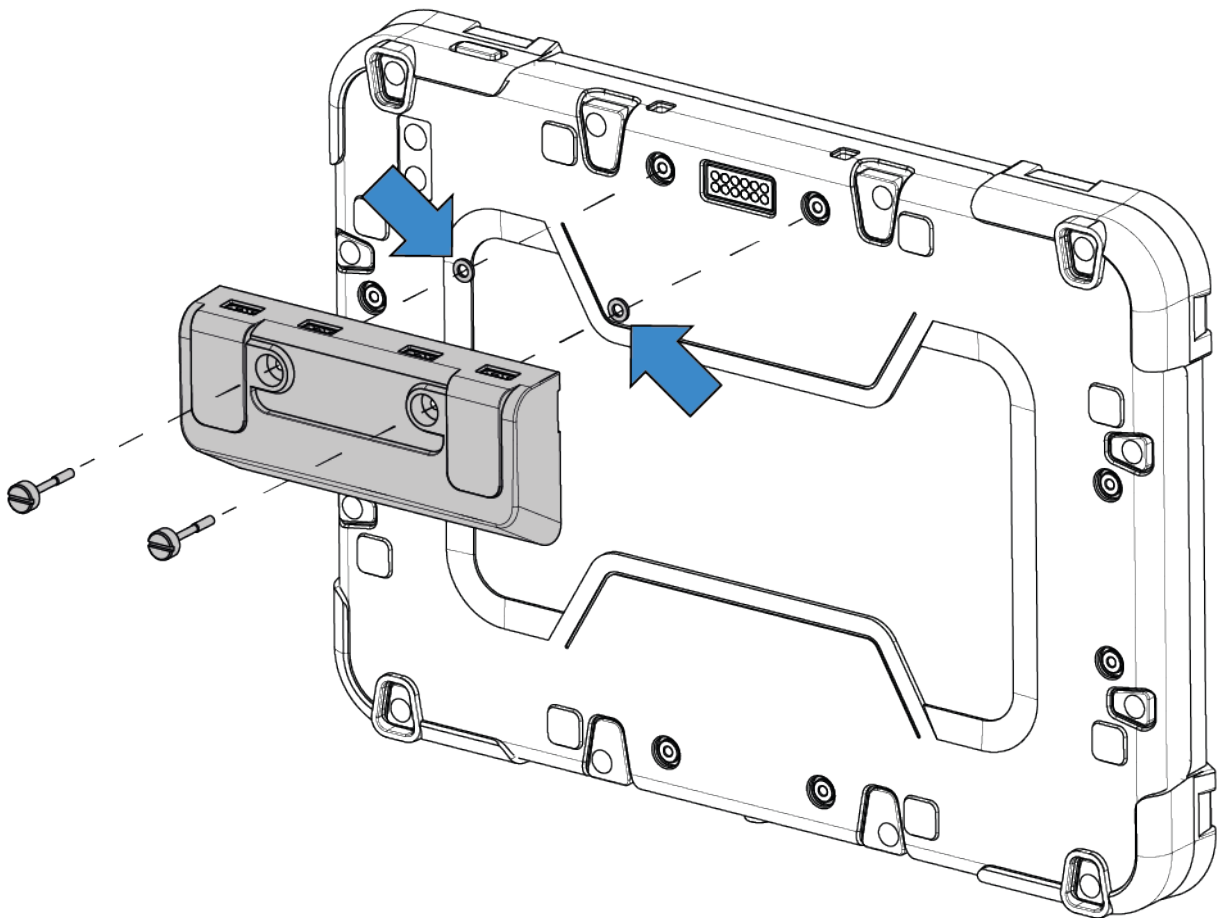

Proceed as follows:

1. Turn the display unit upside down.
2. Select the desired position for installing the module.

3. *Connect the module to the display unit as shown in the image.*
  4. *Secure the module using the specific screws, paying attention to insert the washers indicated in the figure between the module and the display unit. \**
- (\* Skip this step if you chose for the connection only through magnetic contact.*

## 18 OPTIONAL ACCESSORIES

The display unit can be equipped with a comfortable and practical handle that allows moving it, positioning it on support bases and hooking it securely to the steering wheel.

### **NOTICE**

**If positioning it on support bases, make sure the display unit is stable and cannot fall.**

The handle must be fastened on the back of the display unit.

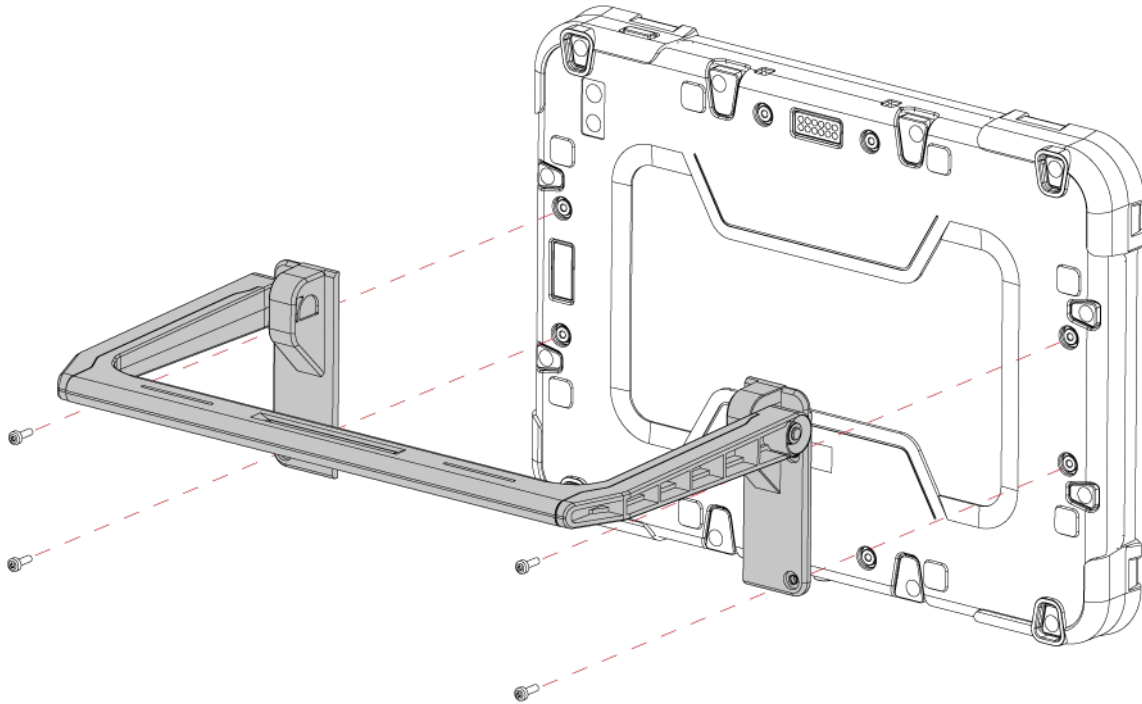

Proceed as follows:

1. Position the handle as indicated in the image.
2. Fasten the handle using the supplied screws.

# 19 BLINK CODES

## NORMAL OPERATION

LED	Visual warning	Display Unit
Green	Powered ON	On
	Slow blink	Sleep (standby)
	Off	Off
Red	Powered ON	Power supply connected Charging in progress
	Blink	Display unit starting phase and battery charging < 10%
	Off	With power supply connected: charging ended Without power supply connected: charging > 10%

## SOFT RESET

LED	Visual warning	Display Unit
Green and Red	Quick, simultaneous blinking	Shutdown for soft reset in progress

## HARD RESET

LED	Visual warning (Power supply disconnected)	Display Unit
Green and Red	Quick, simultaneous blinking	Shutdown for hard reset in progress
	Slow, alternate blinking for approximately 2 minutes	Restart after hard reset in progress

*For further information, see the chapter: POWER ON/OFF.*

## 20 MAINTENANCE

This product does not require special maintenance. However, we recommend the following:

- *carefully follow the instructions provided in this manual;*
- *keep the product clean;*
- *periodically inspect the electrical connections making sure they are in good conditions;*
- *immediately replace any damaged cables;*
- *only use original spare parts or spare parts approved by the manufacturer;*
- *contact your retailer for extraordinary maintenance operations;*

### INFORMATION

*For further help, contact your retailer or the technical assistance service.*

*You can see the list of authorised retailers at the following address: <https://www.texa.com/sales-network>*

## 21 TROUBLESHOOTING

Contact your supplier / retailer for any technical problem that cannot be solved by following the instructions below.

PROBLEM	PROBABLE CAUSE	POSSIBLE SOLUTION
The display unit is not communicating with the Bluetooth peripheral devices.	The Bluetooth peripheral device is switched off.	Switch on the Bluetooth peripheral device.
	The Bluetooth peripheral device is not within range of the display unit.	Place the Bluetooth peripheral device within range of the display unit.
		Place the display unit within range of the Bluetooth peripheral device.
	The communication was not configured correctly.	Operate the configuration through the special function in the software.
	The display unit has been placed near shielding material.	Move the display unit away from shielding material.
	Other wireless communications interfere with the signal.	Move away from possible sources of interference.
If possible, switch off the devices causing the interference.		
Wait and try to communicate again.		

PROBLEM	PROBABLE CAUSE	POSSIBLE SOLUTION
The display unit is not responding to touchscreen commands.	A software procedure is blocked.	Use an external mouse and keyboard.
		Force the shutdown.
The display unit will not switch on.	The internal batteries are low.	Recharge the display unit.
	The CPU and / or the batteries temperature is high.	Wait for the CPU and / or the batteries to cool down, then try again.
The display unit will not communicate with the smartphone / router / access point.	The display unit and the smartphone / router / access point are not within range of each other's radio modules.	Move the two devices closer together. Make sure the WiFi peripheral device is switched on.
	The display unit has been placed near shielding material.	Move the display unit away from shielding material.
The display unit will not communicate with the smartphone / router / access point.	The communication was not configured correctly.	Configure the communication as described in the related manuals.
	The smartphone / router / access point is switched off / not working.	Check the status of the smartphone / router / access point.
The peripheral devices connected to the display unit through the accessory module are not working properly.	The peripheral devices were not detected by the display unit.	Disconnect the peripheral devices from the accessory module then reconnect them. Make sure the contacts on the back side of the display unit are clean. Make sure there are not any undesired objects that are being attracted by the magnets built into the module.
		Disconnect the module from the display unit and then reconnect it. Make sure the contacts on the back side of the display unit are clean. Make sure there are not any undesired objects that are being attracted by the magnets built into the module.

## 22 LEGAL NOTICES

### TEXA S.p.A.

Via 1 Maggio, 9 - 31050 Monastier di Treviso - ITALY

Tax Code - Company Register of Treviso ID No. - VAT No.: 02413550266

Single-shareholder company subject to the direction and coordination activities of Opera Holding S.r.l.

Paid-up share capital 1,000,000 € - R.E.A. (Economic Administrative Index) No. 208102

Legal Representative Bruno Vianello

Phone +39 0422.791.311

Fax +39 0422.791.300

[www.texa.com](http://www.texa.com)

For information regarding the legal notices, please refer to the **International Warranty Booklet** provided with the product.