

Heavy & Medium Duty/ISUZU (North America)/N Series/5.2 Diesel//4HK1/[2017]
 Isuzu/Engine control unit/-/-/-

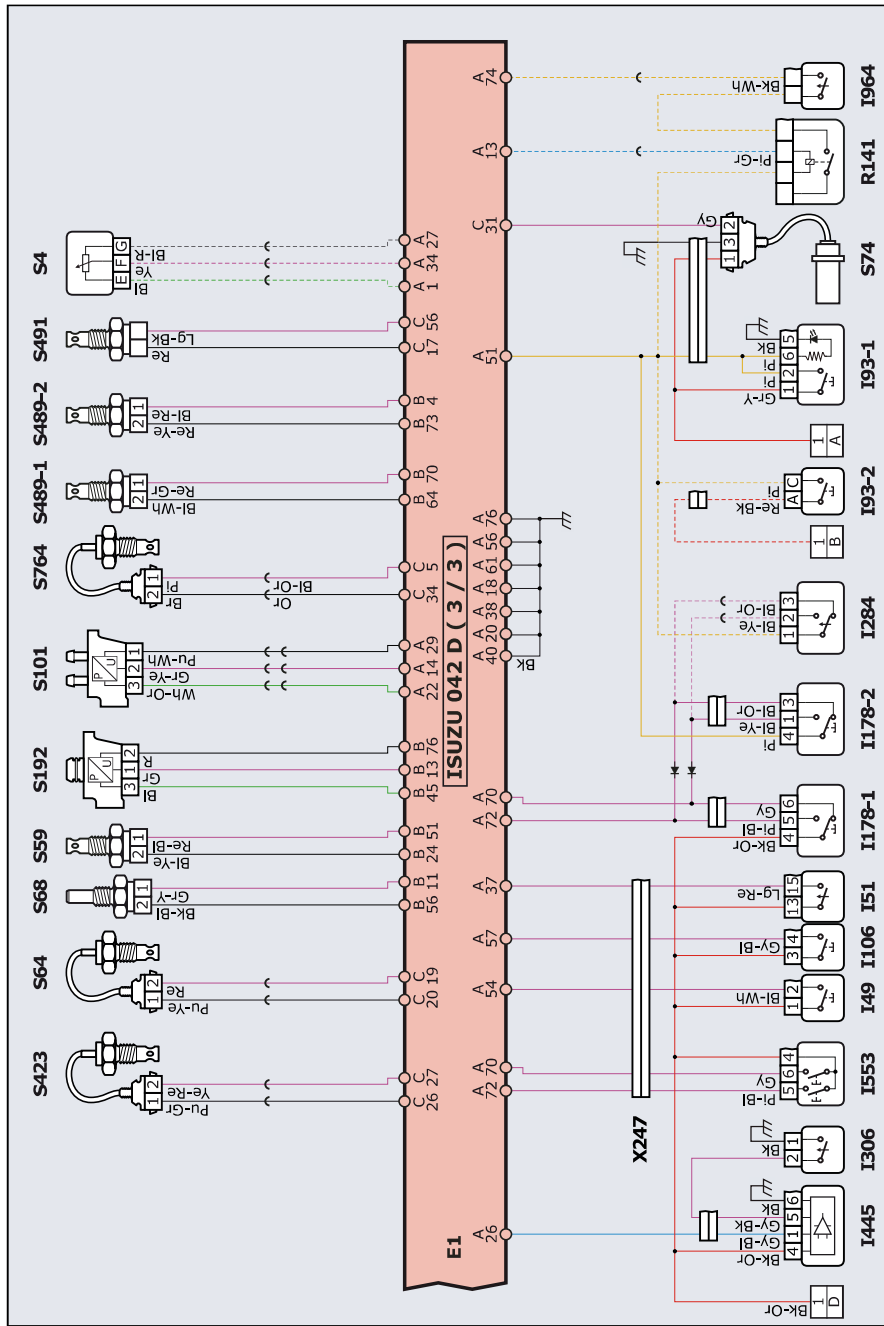

**Heavy & Medium Duty/ISUZU (North America)/N Series/5.2 Diesel//4HK1/[2017]
Isuzu/Engine control unit/-/-/-**

Component list

B1	Starting battery
E1	Engine management control unit
E10	ABS control unit
E11	Instrument panel control unit
E194	Variable geometry turbine control module
E28	Automatic transmission control unit
E3	Body computer
E54	Exhaust gas after treatment electronic control unit
E97	Pre-heating glow plugs module
F13	10 A fuse
F18	10 A fuse
F20	10 A fuse
F21	10 A fuse
F22	10 A fuse
F33	10 A fuse
F35	15 A fuse
FL1	30 A fuse
FL2	60 A fuse
FL4	60 A fuse
FL5	40 A fuse
FL6	30 A fuse
G1	Alternator
H10	Pre-heating glow plug
I1	Ignition Switch
I106	Cruise control switch
I159	Gear shift lever
I178-1	Rear PTO speed selector
I178-2	Rear PTO speed selector
I178-3	Rear PTO speed selector
I178-4	Rear PTO speed selector
I178-5	Rear PTO speed selector
I20	Switch
I284	Rear external power take-off selector switch
I306	Coolant level switch
I445	Coolant level module
I49	Particulate filter regeneration switch
I51	Engine brake switch
I52	Rear power take-off brake switch
I553	Set and resume speed switch
I922	Front PTO emergency stop switch
I93-1	Power take-off switch
I93-2	Power take-off switch
I964	PTO selection switch

J201	Magnetic common rail injector of cylinder n. 1
J202	Magnetic common rail injector of cylinder n. 2
J203	Magnetic common rail injector of cylinder n. 3
J204	Magnetic common rail injector of cylinder n. 4
M1	Starter motor
M12	Intake manifold throttle valve motor with potentiometer
M30	EGR throttle motor module
M72	Variable geometry turbine control motor
PS	The dotted connections may not be present
R141	Power take off relay
R45	Starter motor relay
R5	Immobilizer relay
R87	Main relay
S101	Particulate filter exhaust gas differential pressure sensor
S149	Variable geometry turbine position sensor
S189	High pressure fuel sensor
S19	Hall timing sensor
S192	Boost pressure sensor
S2	Digital air mass meter
S22	Hall effect speed sensor
S34	Electronic accelerator pedal sensor
S365	Particulate filter meter fuel input pressure sensor
S4	PTO accelerator potentiometer
S423	Exhaust gas temperature sensor upstream of the oxidation catalyst
S489-1	Exhaust gas recirculation temperature sensor
S489-2	Exhaust gas recirculation temperature sensor
S491	Boost air temperature downstream of the intercooler
S55	Oil pressure sensor
S59	Intake air temperature sensor
S60	Fuel temperature sensor
S64	Exhaust gas temperature sensor upstream of the particulate filter
S68	Coolant temperature sensor
S74	Vehicle speed Hall sensor
S764	Exhaust gas temperature sensor downstream of the turbine
V21	High pressure fuel metering solenoid valve
V371	Particulate filter fuel meter solenoid valve
V86	Engine brake solenoid valve
X1	Diagnostic socket
X247	Cabin-chassis interconnection

**Heavy & Medium Duty/ISUZU (North America)/N Series/5.2 Diesel//4HK1/[2017]
Isuzu/Engine control unit/-/-/**

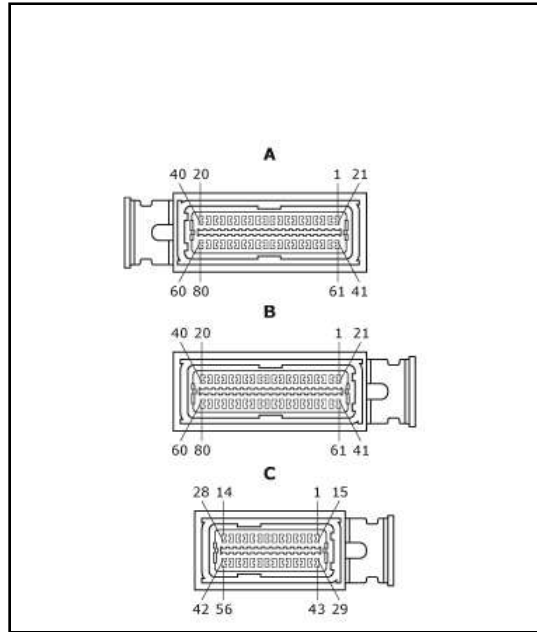

Wiring side connector pinout

- A = 80
- B = 80
- C = 56