

Heavy & Medium Duty/ISUZU (North America)/N Series/5.2 Diesel//4HK1/[2012]
Isuzu/Engine control unit/-/-/With automatic transmission

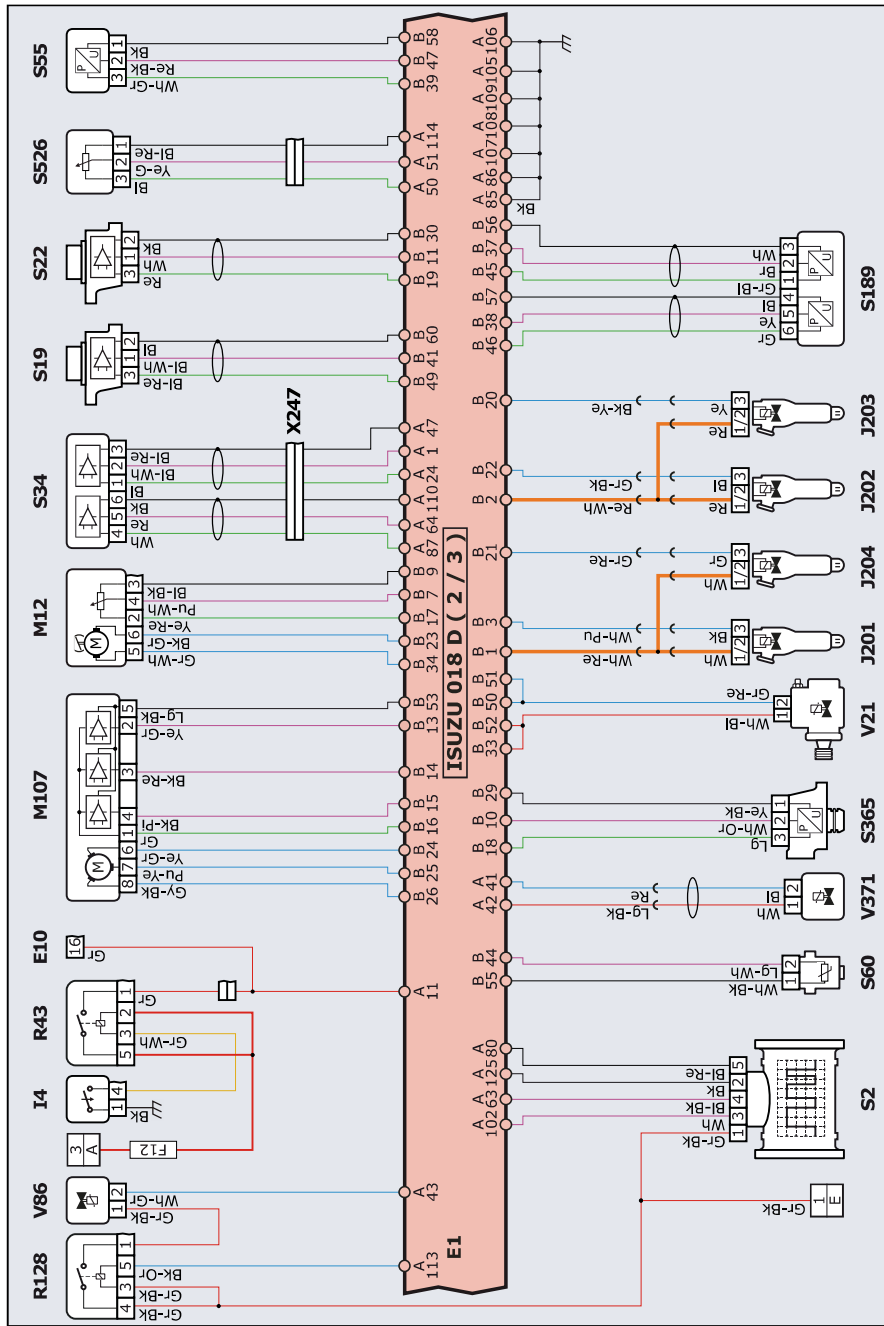

**Heavy & Medium Duty/ISUZU (North America)/N Series/5.2 Diesel//4HK1/[2012]
Isuzu/Engine control unit/-/-/With automatic transmission**

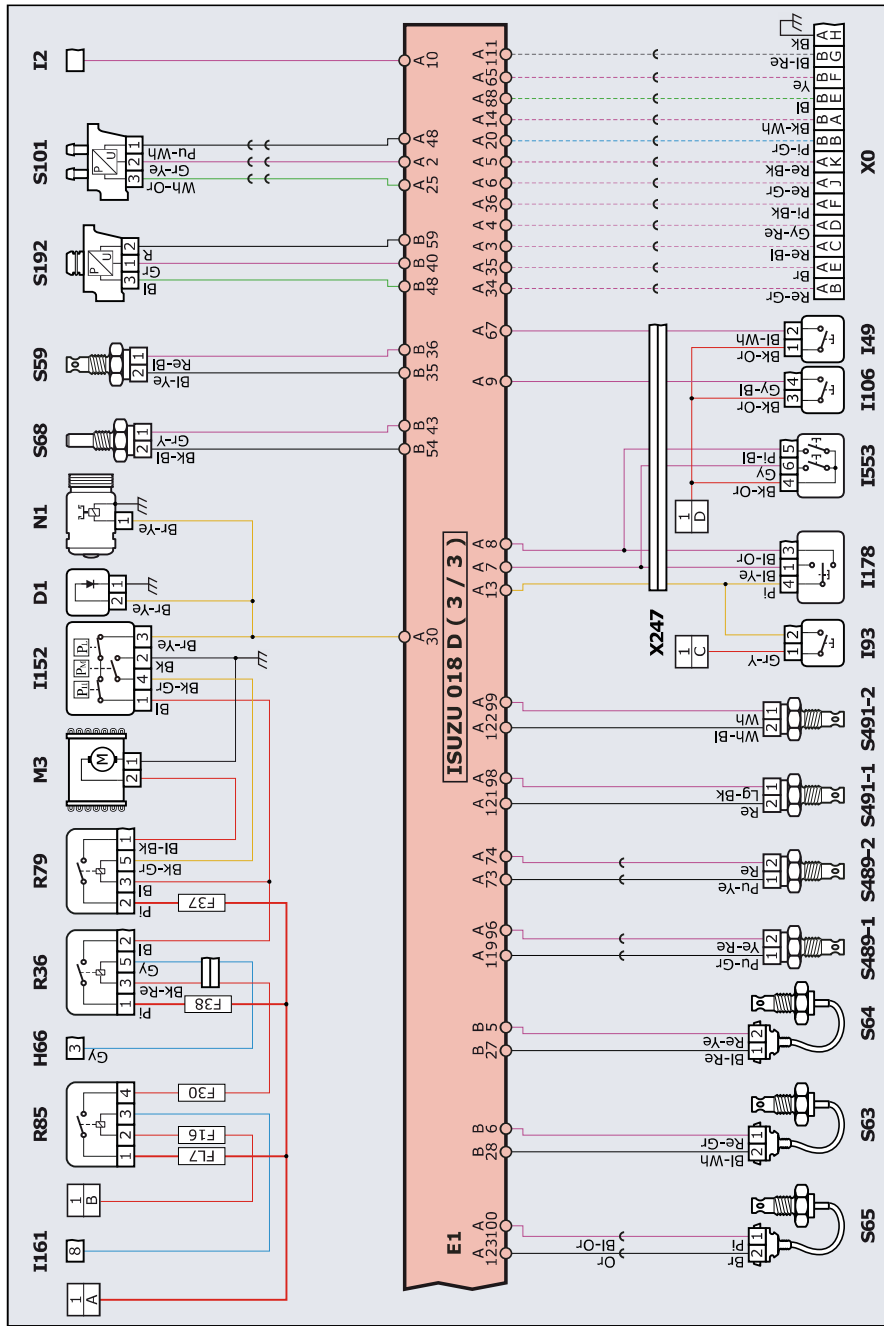

**Heavy & Medium Duty/ISUZU (North America)/N Series/5.2 Diesel//4HK1/[2012]
Isuzu/Engine control unit/-/-/With automatic transmission**

Component list

B1	Starting battery
D1	Diode
E1	Engine management control unit
E10	ABS control unit
E11	Instrument panel control unit
E194	Variable geometry turbine control module
E28	Automatic transmission control unit
E97	Pre-heating glow plugs module
F12	10 A fuse
F13	10 A fuse
F16	15 A fuse
F20	10 A fuse
F21	10 A fuse
F22	10 A fuse
F30	10 A fuse
F33	10 A fuse
F37	20 A fuse
F38	10 A fuse
FL1	30 A fuse
FL2	60 A fuse
FL4	60 A fuse
FL5	40 A fuse
FL6	30 A fuse
FL7	40 A fuse
G1	Alternator
H10	Pre-heating glow plug
H66	Passenger compartment heating thermostat module
I1	Ignition Switch
I106	Cruise control switch
I152	A/C triple pressure switch
I159	Gear shift lever
I161	Climate control selector
I178	Rear PTO speed selector
I2	Brake pedal switch
I306	Coolant level switch
I4	Brake light switch
I445	Coolant level module
I49	Particulate filter regeneration switch
I51	Engine brake switch
I553	Set and resume speed switch
I93	Power take-off switch
J201	Magnetic common rail injector of cylinder n. 1
J202	Magnetic common rail injector of cylinder n. 2

J203	Magnetic common rail injector of cylinder n. 3
J204	Magnetic common rail injector of cylinder n. 4
M1	Starter motor
M107	EGR throttle control motor with digital position sensor
M12	Intake manifold throttle valve motor with potentiometer
M3	Engine cooling fan motor and air conditioner
M72	Variable geometry turbine control motor
N1	Compressor clutch engagement magnet
PS	The dotted connections may not be present
R128	Engine brake relay
R36	Compressor clutch engagement relay
R43	Stop lights relay
R45	Starter motor relay
R5	Immobilizer relay
R79	Engine cooling and A/C fan relay
R85	Air conditioning fan relay
R87	Main relay
S101	Particulate filter exhaust gas differential pressure sensor
S149	Variable geometry turbine position sensor
S189	High pressure fuel sensor
S19	Hall timing sensor
S192	Boost pressure sensor
S2	Digital air mass meter
S22	Hall effect speed sensor
S34	Electronic accelerator pedal sensor
S365	Particulate filter meter fuel input pressure sensor
S489-1	Exhaust gas recirculation temperature sensor
S489-2	Exhaust gas recirculation temperature sensor
S491-1	Boost air temperature downstream of the intercooler
S491-2	Boost air temperature downstream of the intercooler
S526	Idle control potentiometer
S55	Oil pressure sensor
S59	Intake air temperature sensor
S60	Fuel temperature sensor
S63	Upstream exhaust gas temperature sensor of the catalyst
S64	Exhaust gas temperature sensor upstream of the particulate filter
S65	Exhaust gas temperature sensor upstream of the turbine
S68	Coolant temperature sensor
S74	Vehicle speed Hall sensor
V21	High pressure fuel metering solenoid valve
V371	Particulate filter fuel meter solenoid valve
V86	Engine brake solenoid valve
X0	Interconnection plug
X1	Diagnostic socket
X247	Cabin-chassis interconnection

**Heavy & Medium Duty/ISUZU (North America)/N Series/5.2 Diesel//4HK1/[2012]
Isuzu/Engine control unit/-/-/With automatic transmission**

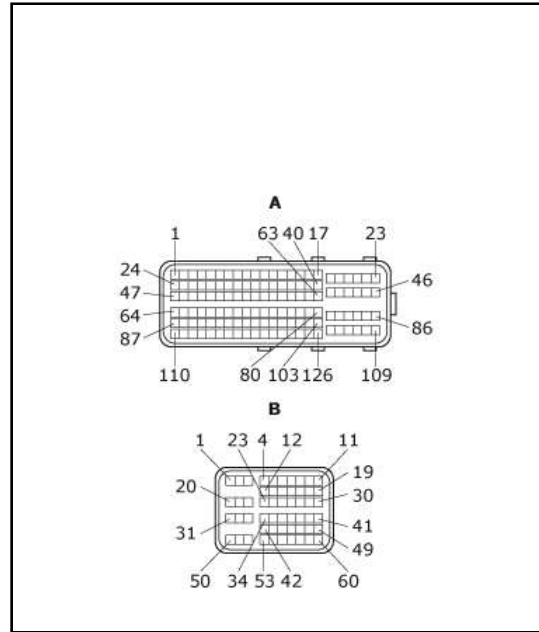

Wiring side connector pinout

A = 126

B = 60